

The current proposal is:

Preservation Department – Item 2, LPC-24-08494

17 Fillmore Place – Fillmore Place Historic District
Borough of Brooklyn

Note: this is a Public Meeting item. No public testimony will be received today as the hearing on this item is closed



NOTE:
REAR FACADE IS NOT VISIBLE
FROM STREET



Fillmore Place Historic District



Fillmore Place Historic District
Borough of Brooklyn, NY
Landmarks Preservation Commission

Calendared: January 13, 2009
Public Hearing: March 24, 2009
Designated: May 12, 2009

Boundary of Historic District
Tax Map Lots in Historic District



SITE PLAN

SCOPE OF WORK

1. EXTEND 2ND FLOOR AND 3RD FLOOR IN REAR
2. NEW DOORS AT BASEMENT AND 1ST. FLOOR REAR LEVEL
3. NEW WINDOWS ON 2ND AND 3RD FLOOR REAR LEVEL
4. EXTEND EXISTING DECK
5. NEW STAIRS AND RAILING TO THE REAR YARD

KEY

17 FILLMORE PL	1 STORY ADDITION	3 STORY ADDITION
ADJACENT PROPERTIES	DECK	4 STORY ADDITION
VIEW LOCATION		

SCALE: 1/64" = 1'-0"

17 FILLMORE PL COMMUNITY BOARD PRESENTATION

SITE PLAN / STREET VIEW

A00



19 FILLMORE PL

17 FILLMORE PL

17 FILLMORE PL

15 FILLMORE PL





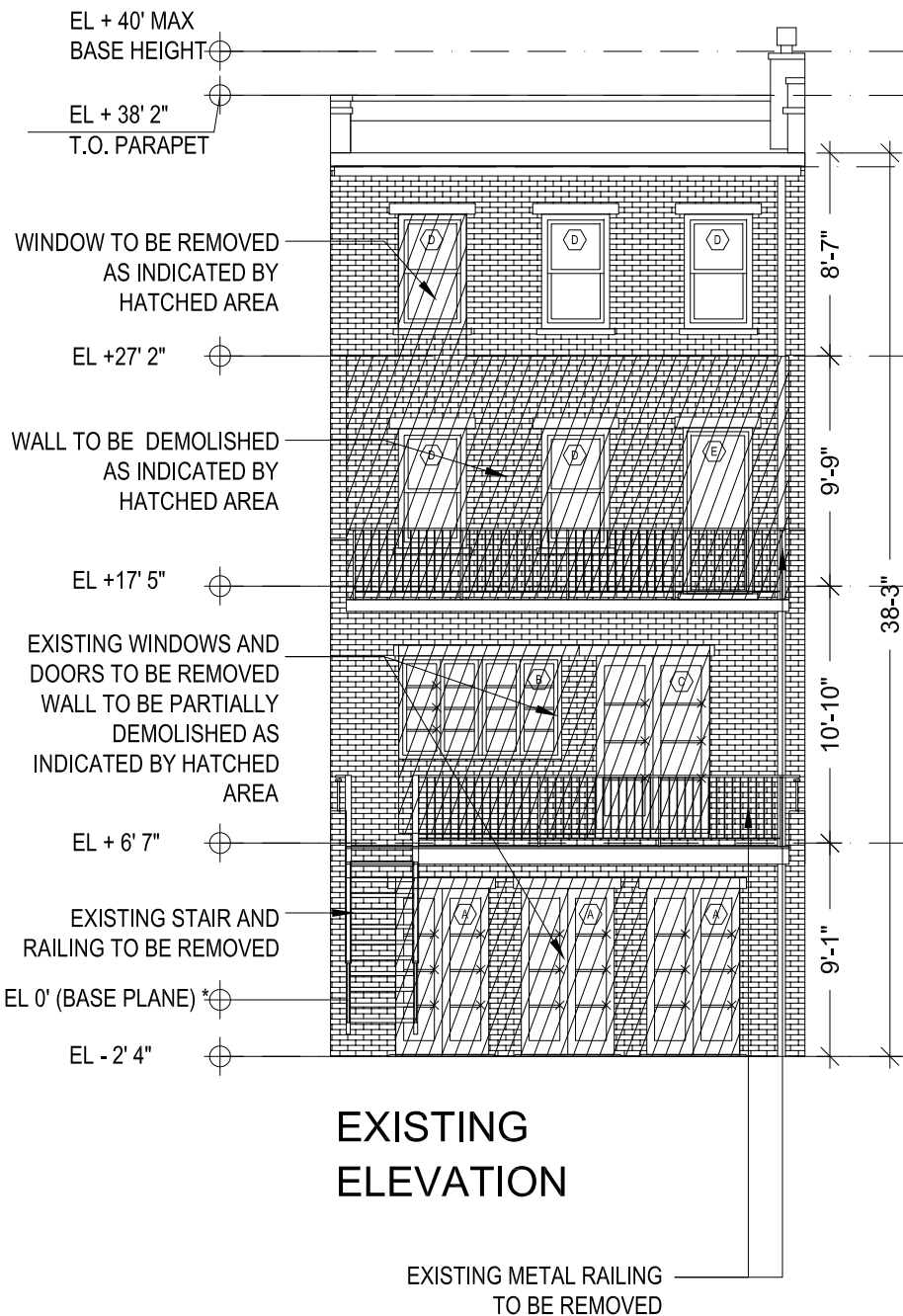

EXISTING
ELEVATION



- EXIST WINDOWS TO REMAIN
- PROPOSED NEW WINDOWS
- NEW DOOR
- 1/2 " TEMPERED GLASS RAILING

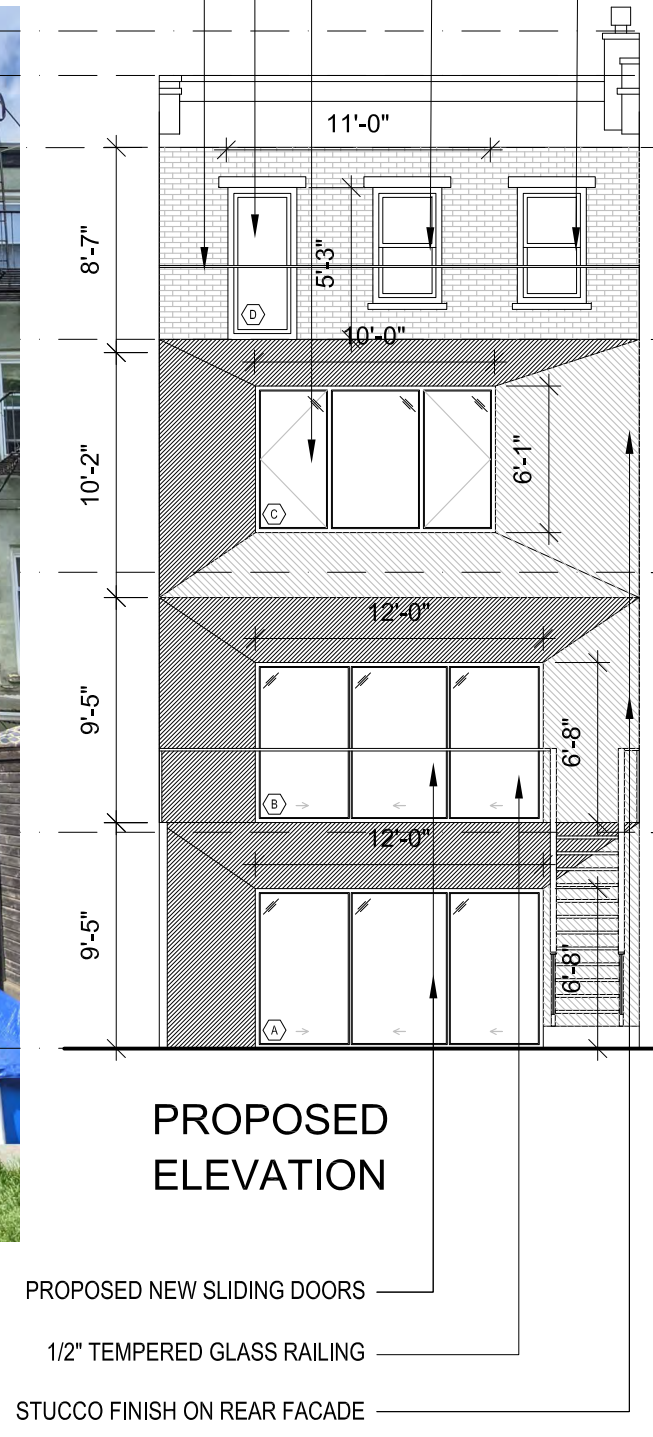

PROPOSED
ELEVATION

- PROPOSED NEW SLIDING DOORS
- 1/2 " TEMPERED GLASS RAILING
- STUCCO FINISH ON REAR FACADE

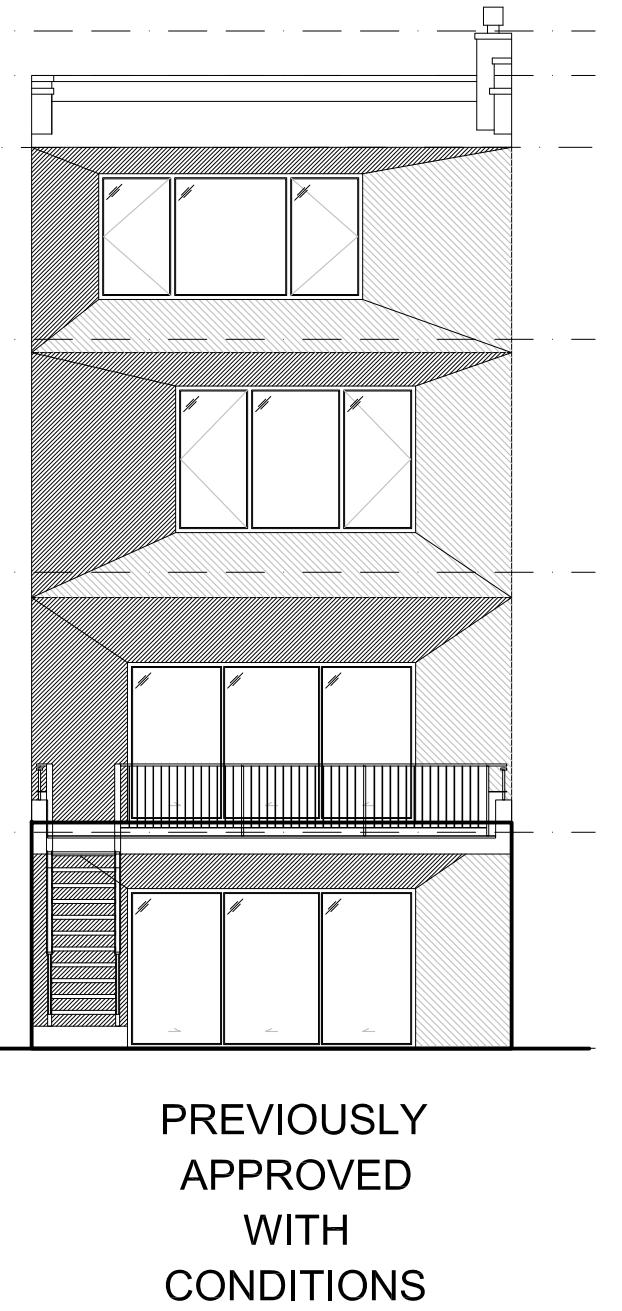

PREVIOUSLY
APPROVED
WITH
CONDITIONS

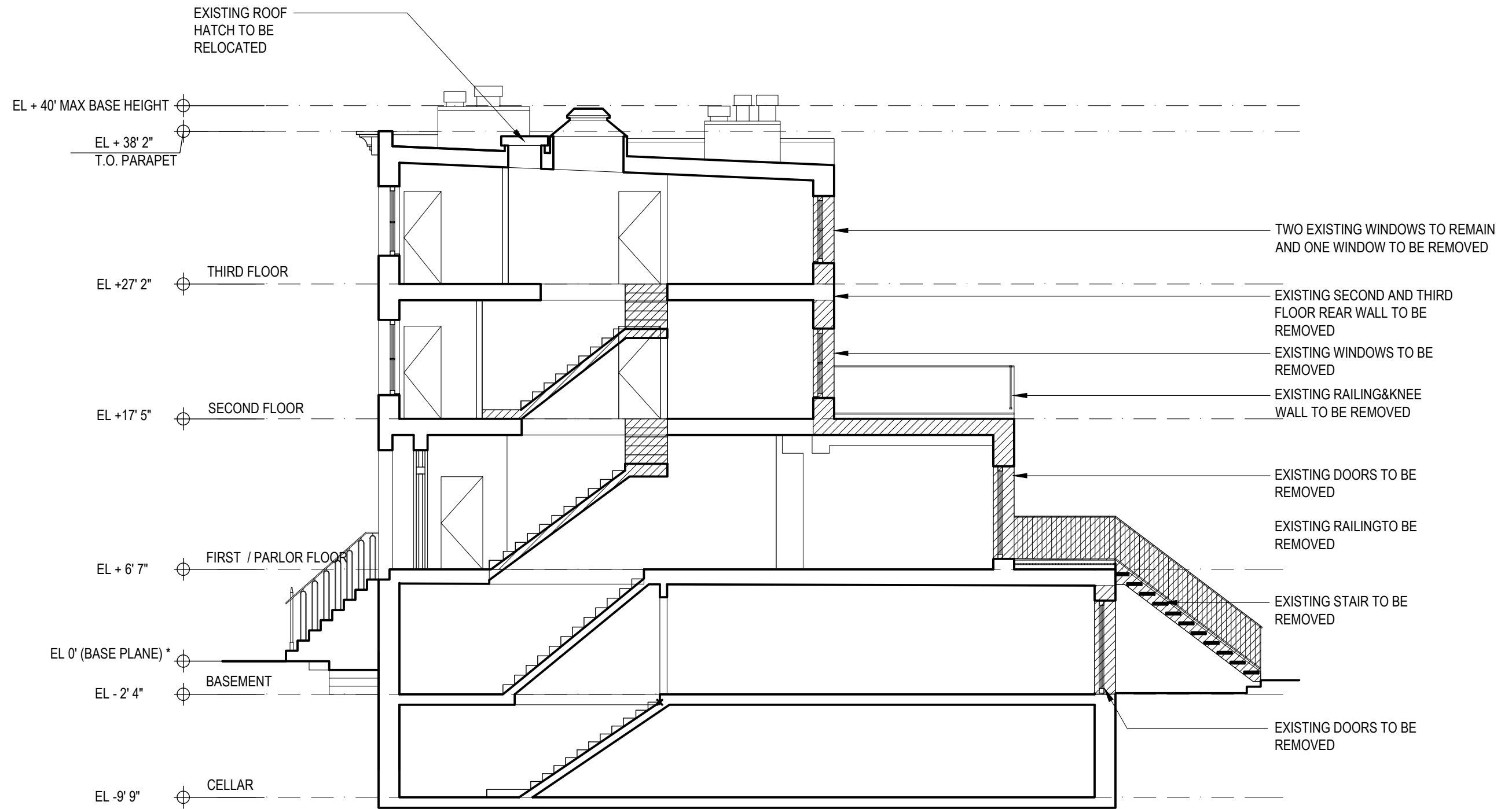

KEY

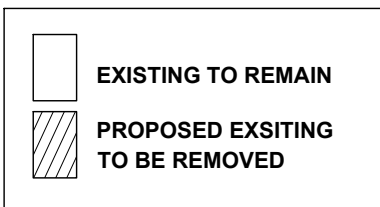

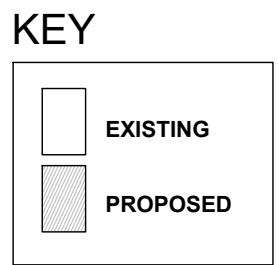
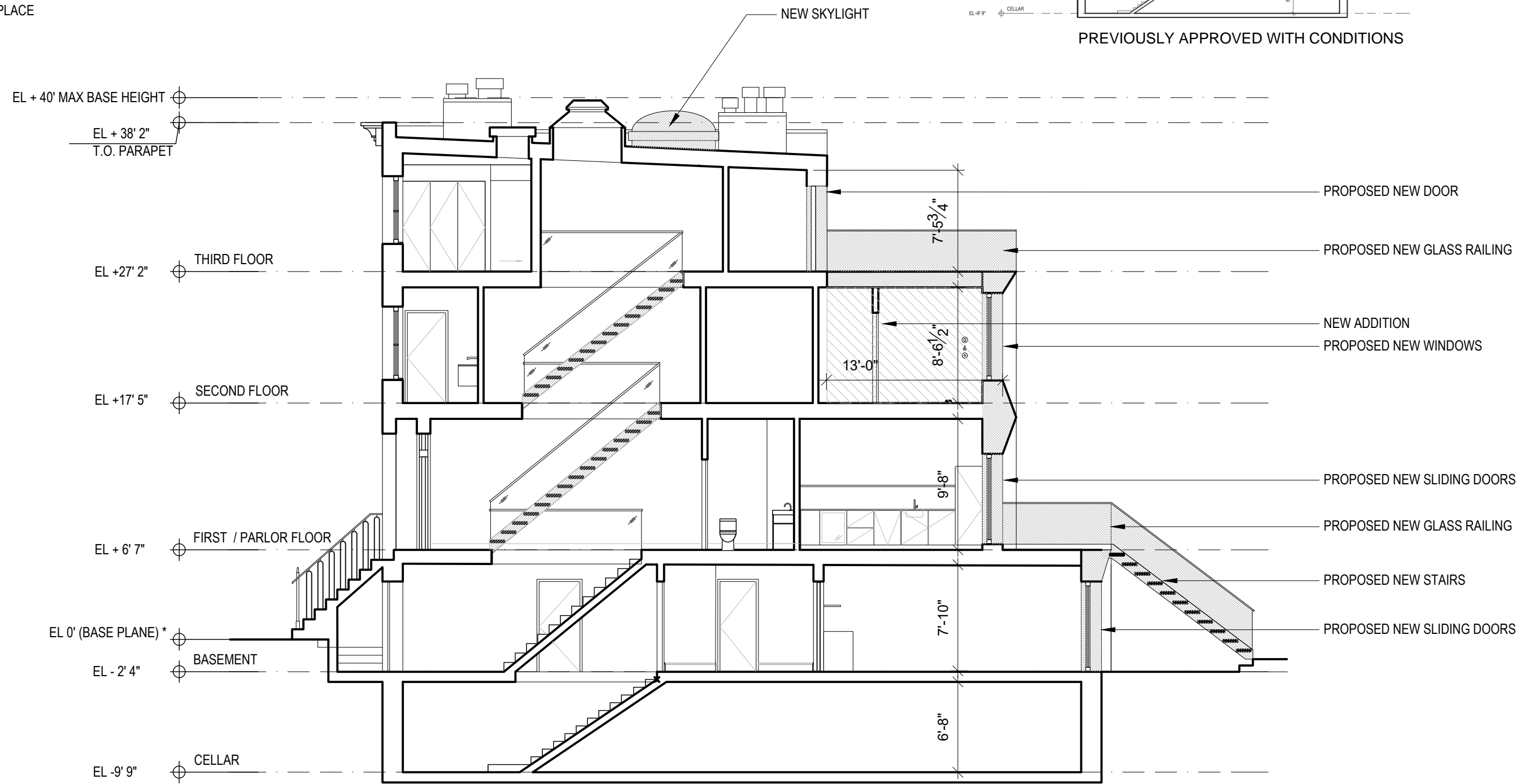
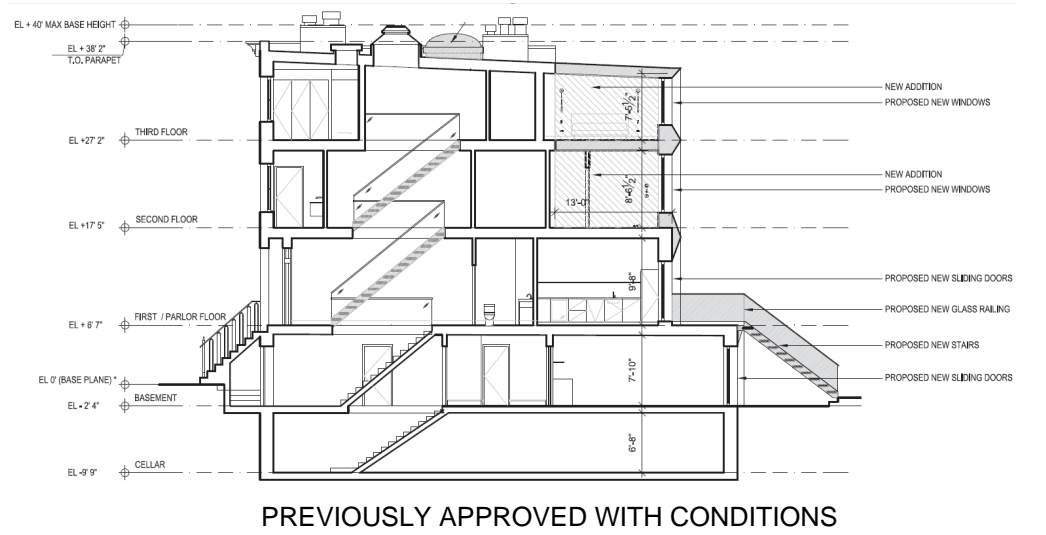
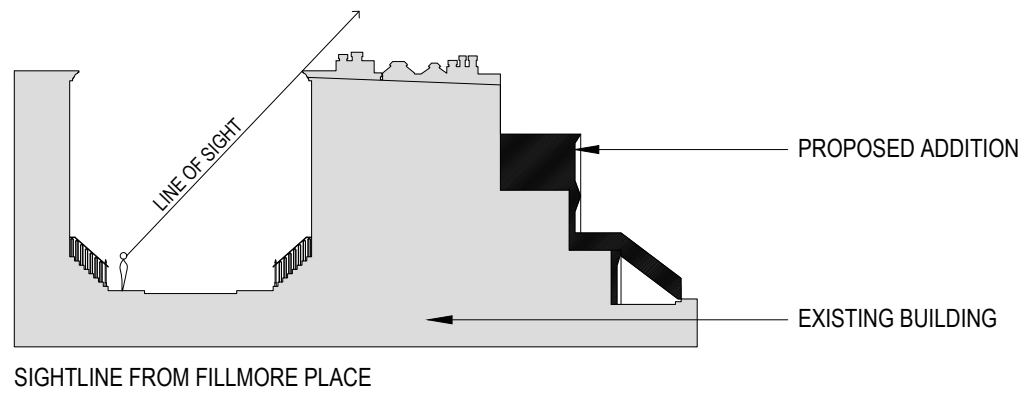

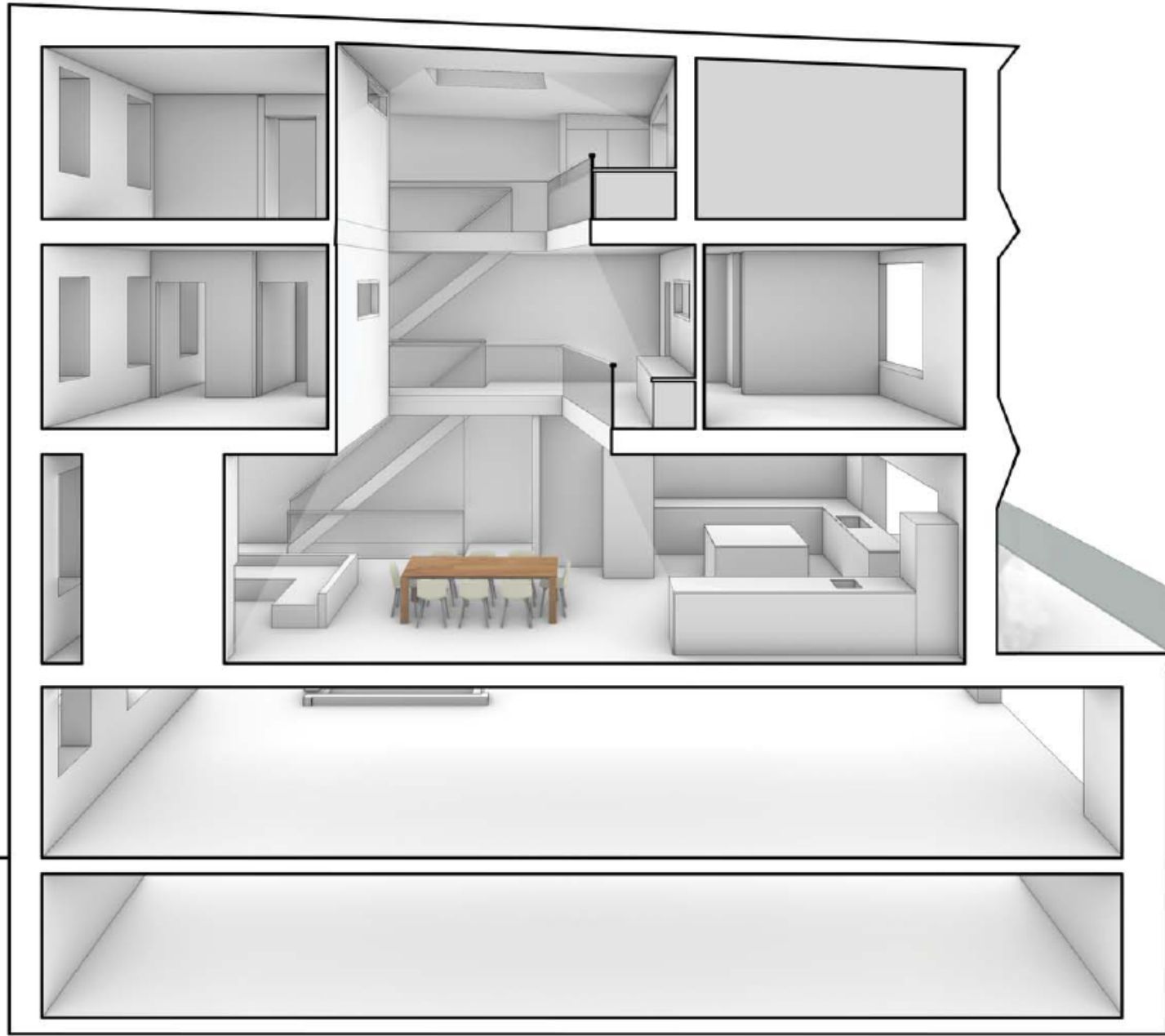

PREVIOUSLY APPROVED WITH CONDITIONS

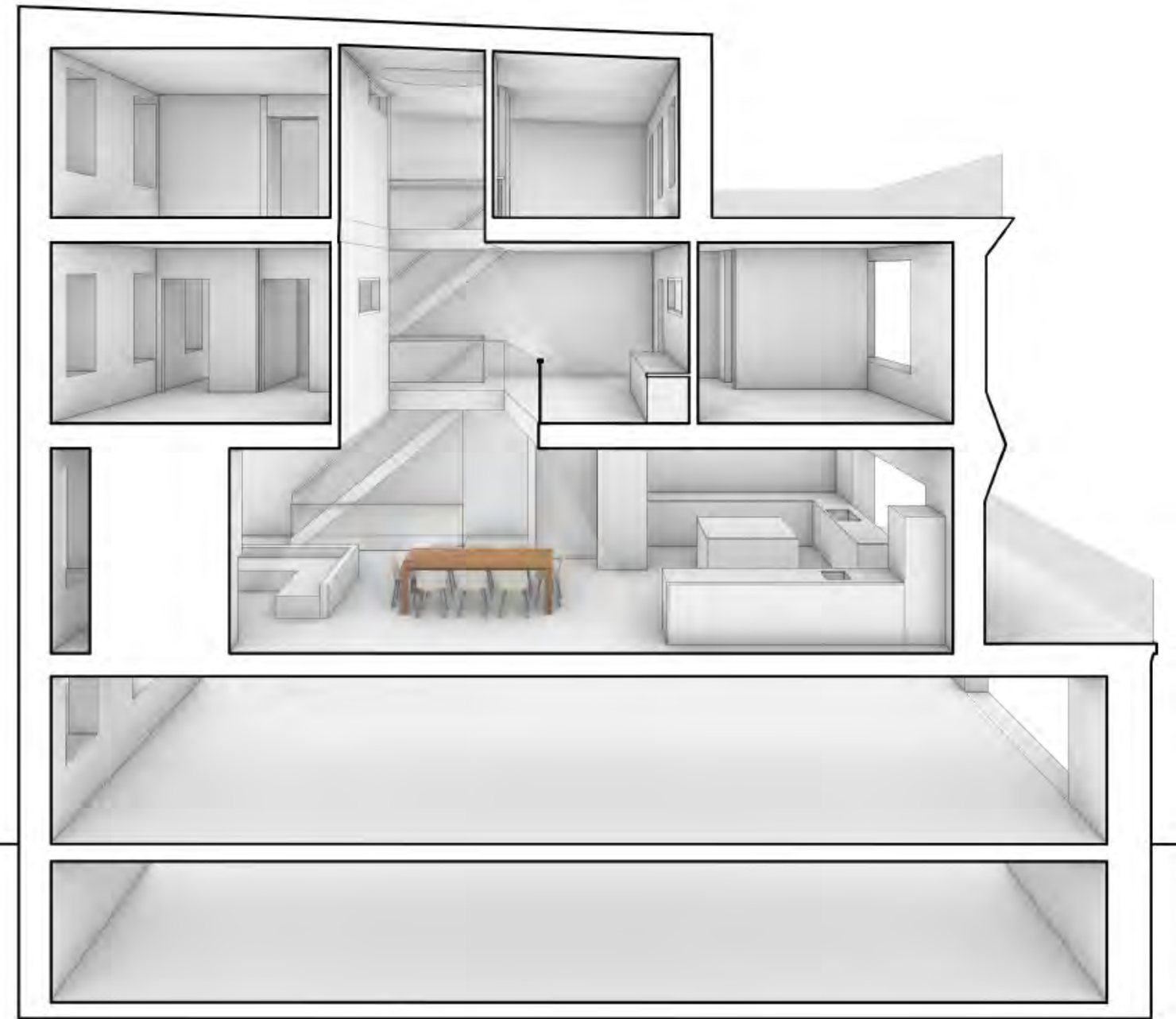

PROPOSED

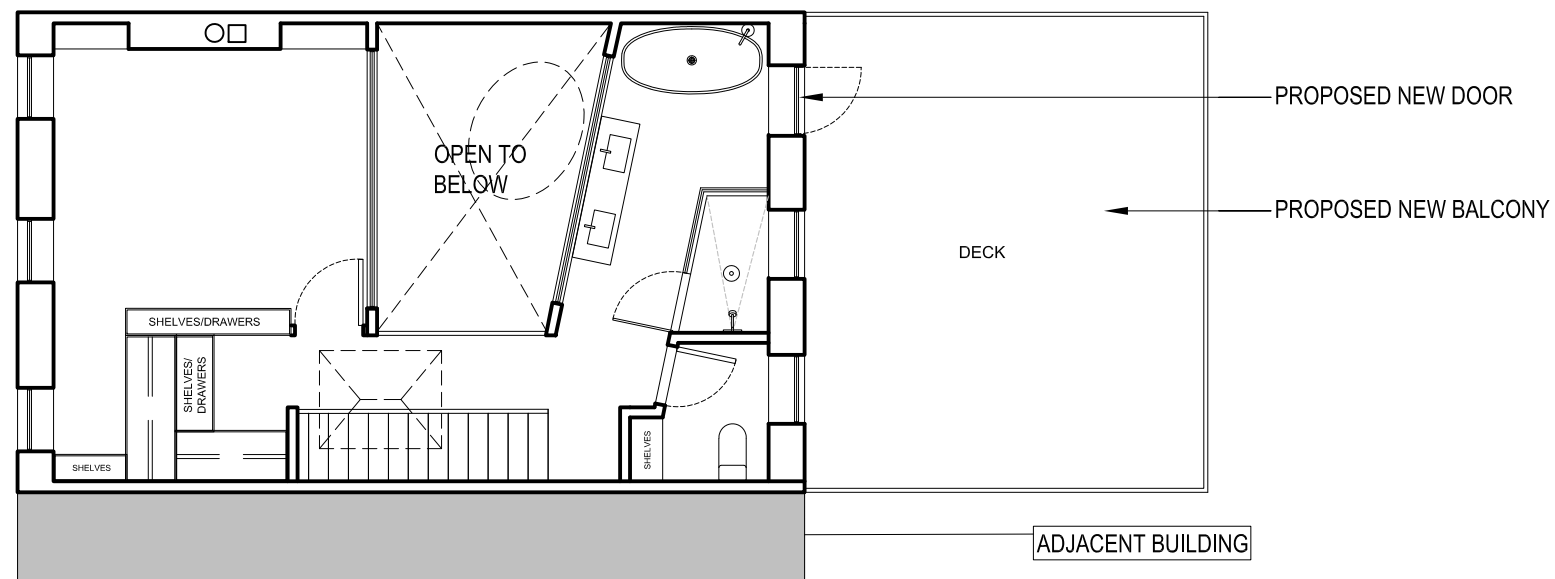

THIRD FLOOR

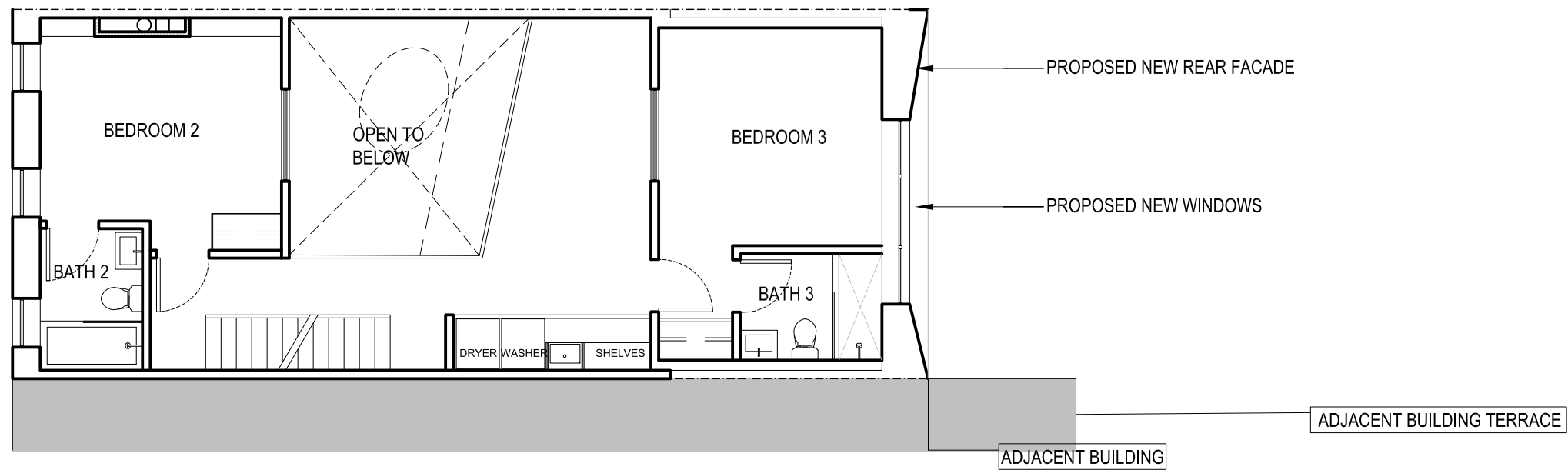

SECOND FLOOR

KEY

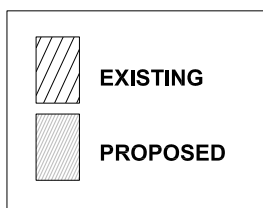

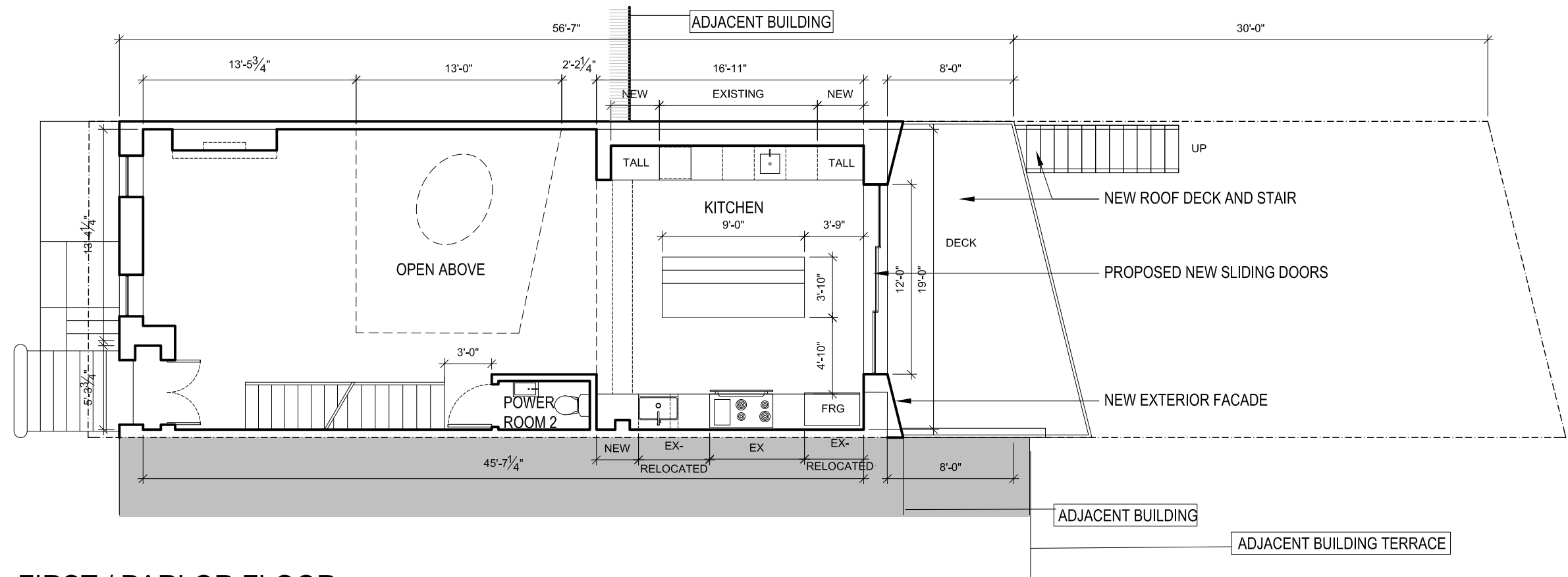

FIRST / PARLOR FLOOR

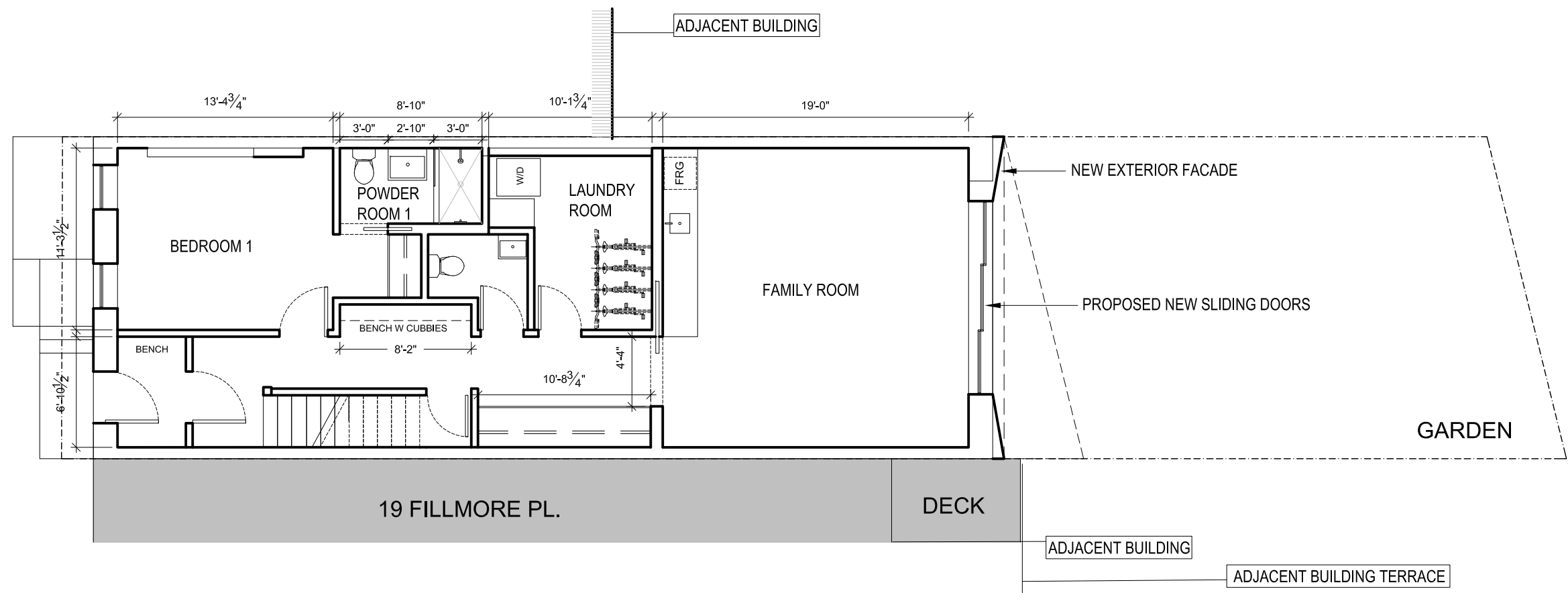

BASEMENT FLOOR

KEY

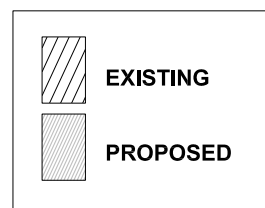



EXISTING ADJACENT
BUILDING

PROPOSED
ELEVATION

EXISTING ADJACENT
BUILDING



PREVIOUS



PROPOSED REVISED DESIGN

NEW SPECIFICATIONS FOR DOORS 'A' & 'B':
 PELLA- ARCHITECT SERIES CONTEMPORARY, QUAD SLIDING DOOR,
 ENDURA CLAD EXTERIOR, NON-STANDARD SIZE
 DOORS WITH FRAME EXPANDER (TRIMMED, FIELD
 APPLIED, AND SEALED BY OTHERS)
 CASING (FIELD APPLIED AD SEALED BY OTHERS),
 COLOR -BLACK

NEW SPECIFICATIONS FOR WINDOWS 'C' & 'D':
 PELLA- ARCHITECT SERIES CONTEMPORARY, TRADITIONAL
 CASEMENT WINDOW, ENDURA CLAD EXTERIOR, NON-STANDARD SIZE
 WINDOWS WITH FRAME EXPANDER (TRIMMED,
 FIELD APPLIED, AND SEALED BY OTHERS)
 CASING (FIELD APPLIED AD SEALED BY OTHERS),
 COLOR -BLACK

PROPOSED DOORS 'A' & 'B' SECTION

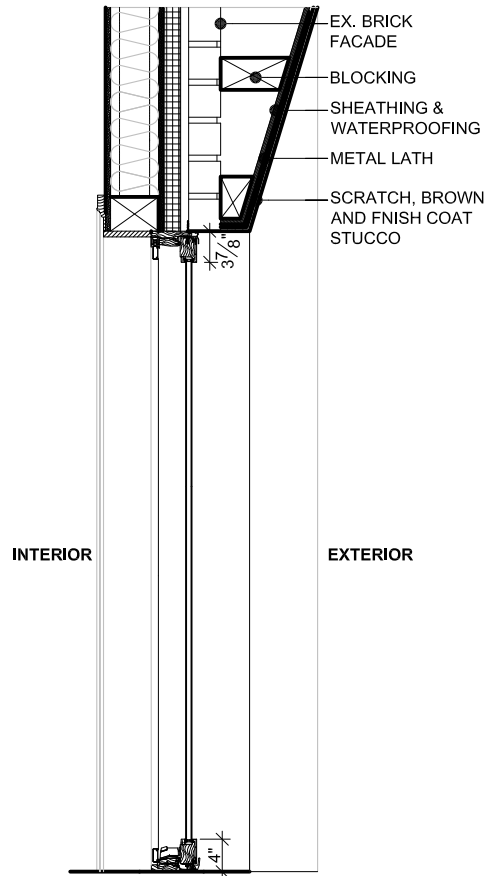

1 PROPOSED DOORS 'A' & 'B'
 SCALE: 1/2"=1'-0"

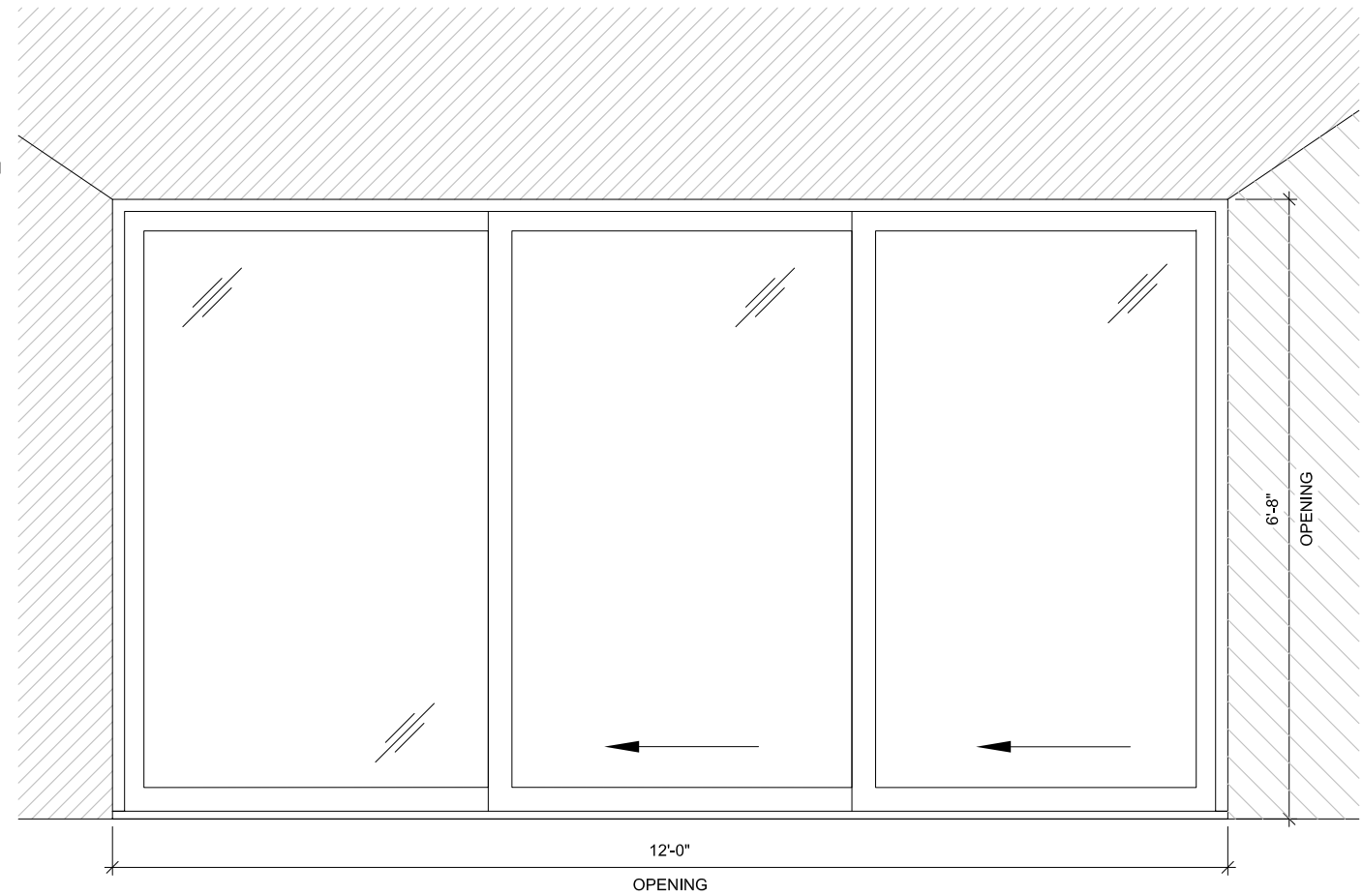

2 PROPOSED WINDOWS 'C'
 SCALE: 1/2"=1'-0"

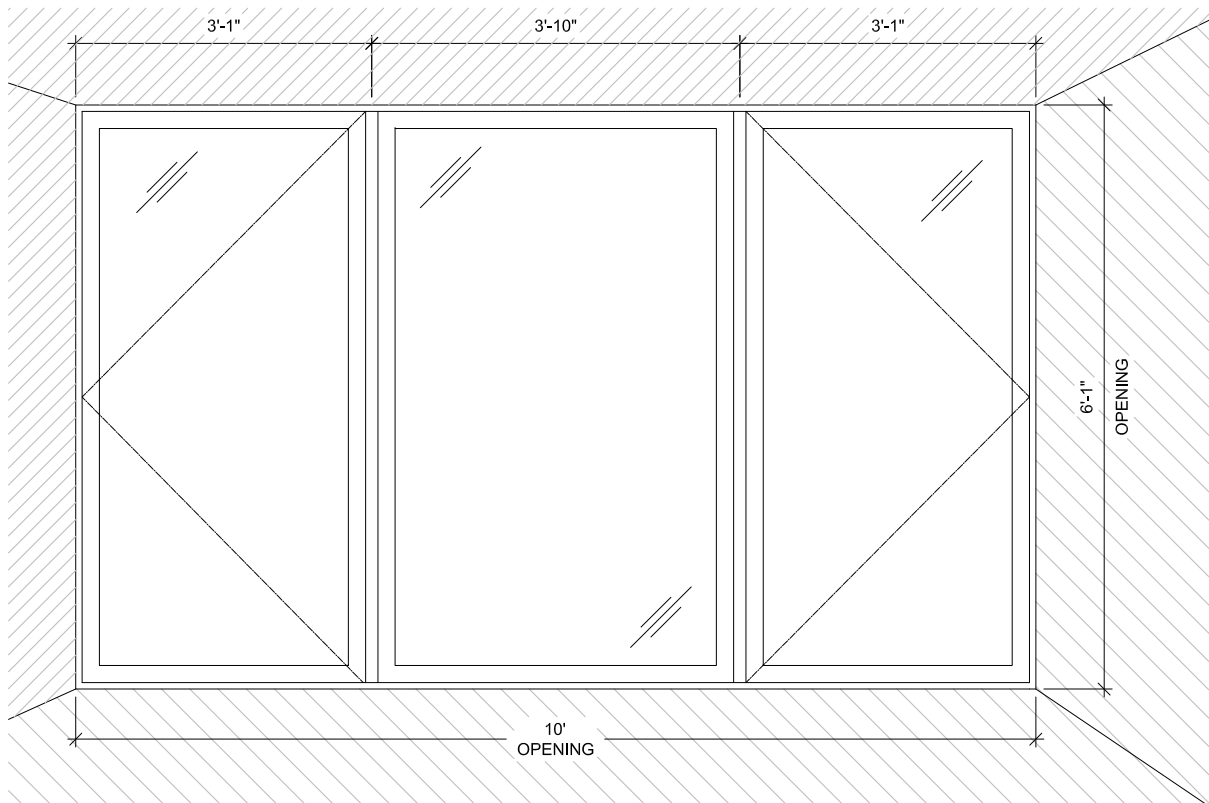

PROPOSED WINDOWS 'C' SECTION

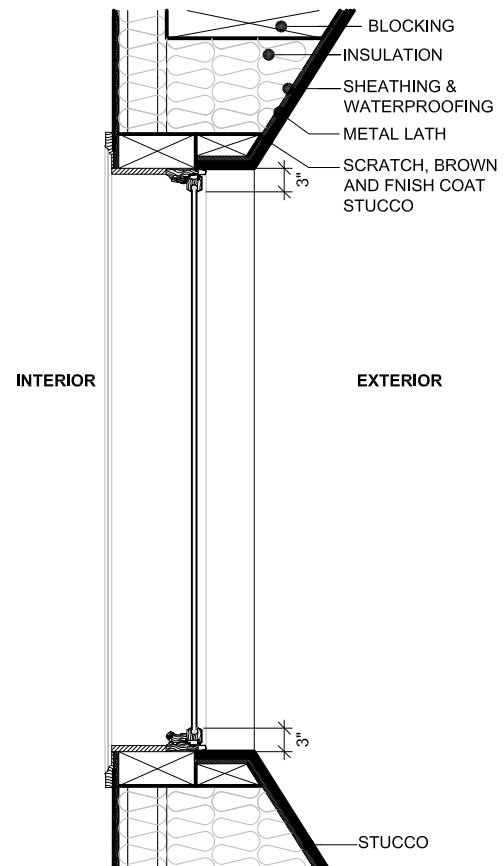

3 PROPOSED DOOR 'D'
 SCALE: 1/2"=1'-0"

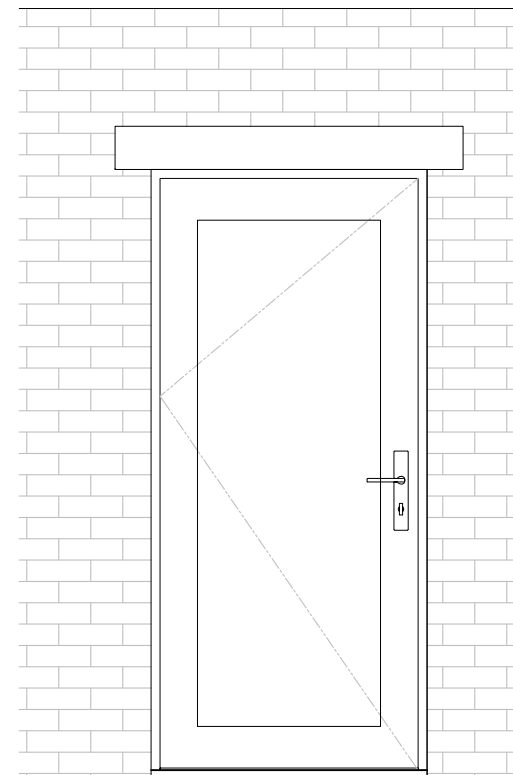

PROPOSED DOOR 'D' SECTION

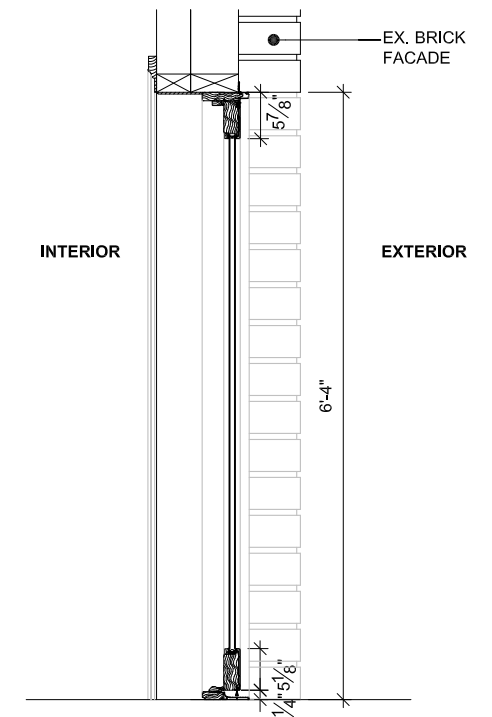

EAST 61ST STREET,
NEW YORK, NY

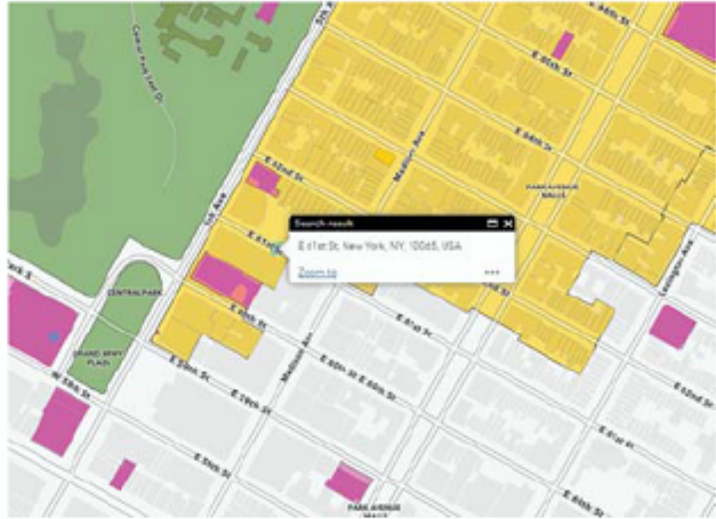

FRONT



REAR

313 W 77TH STREET,
NEW YORK, NY



FRONT



REAR

E8

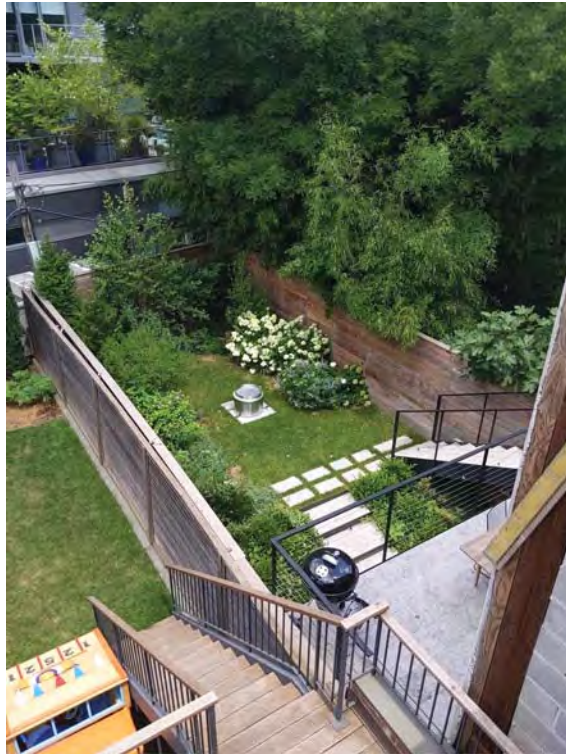

E7

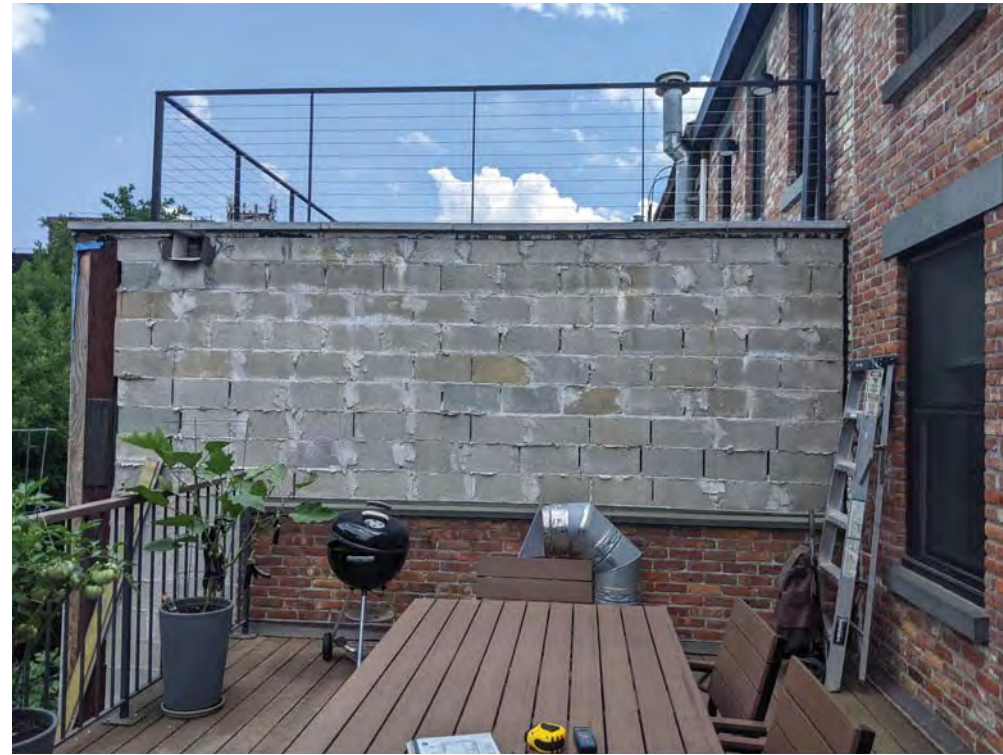

E6



E5



E4

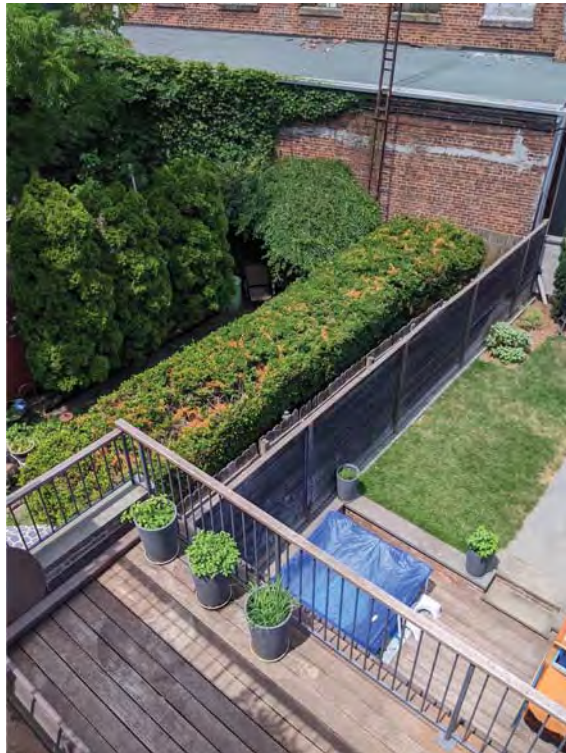

E3



E2



E1

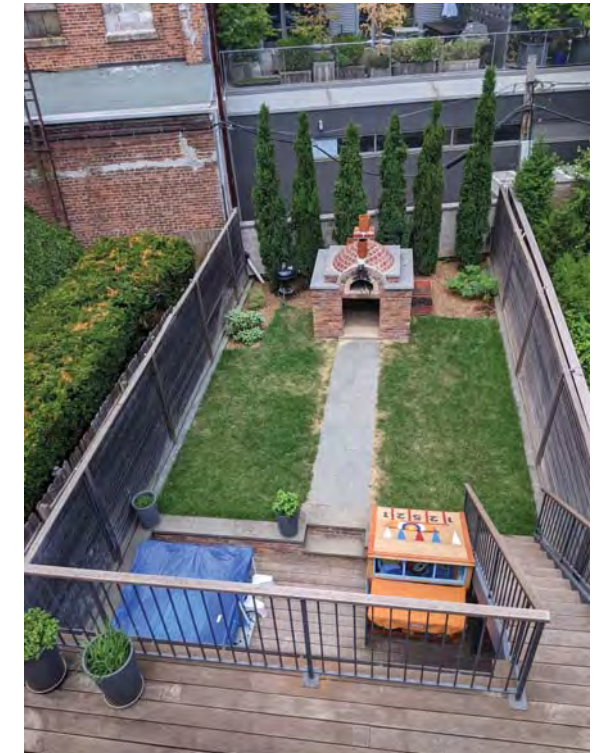



4



3



2



1



8



7



6



5



12



11



10

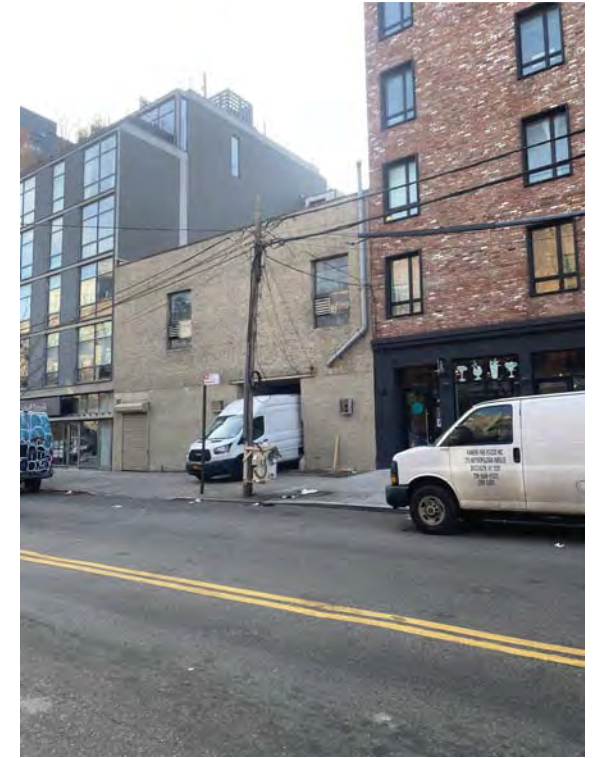

9



16

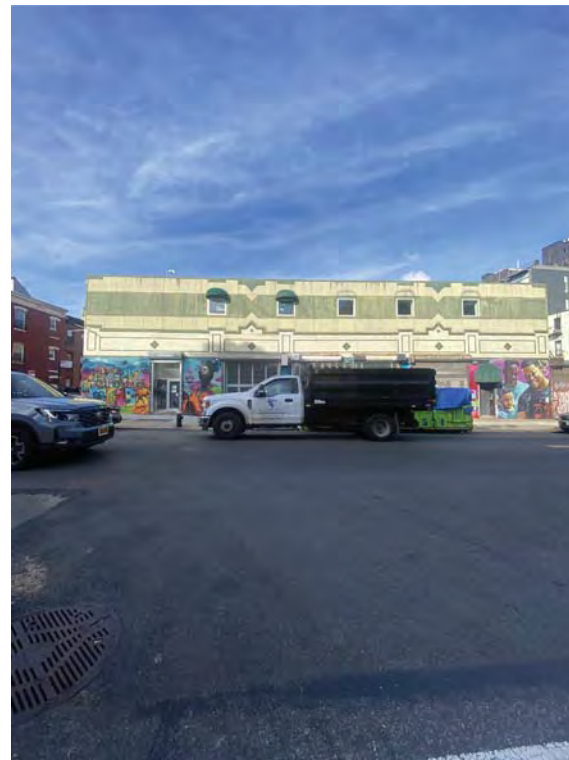

15



14



13



18



17

END OF PRESENTATION

FOLLOWING ARE SUPPLEMENTAL
DOCUMENTS ONLY

The current proposal is:

Preservation Department – Item 2, LPC-24-08494

17 Fillmore Place – Fillmore Place Historic District
Borough of Brooklyn

Note: this is a Public Meeting item. No public testimony will be received today as the hearing on this item is closed

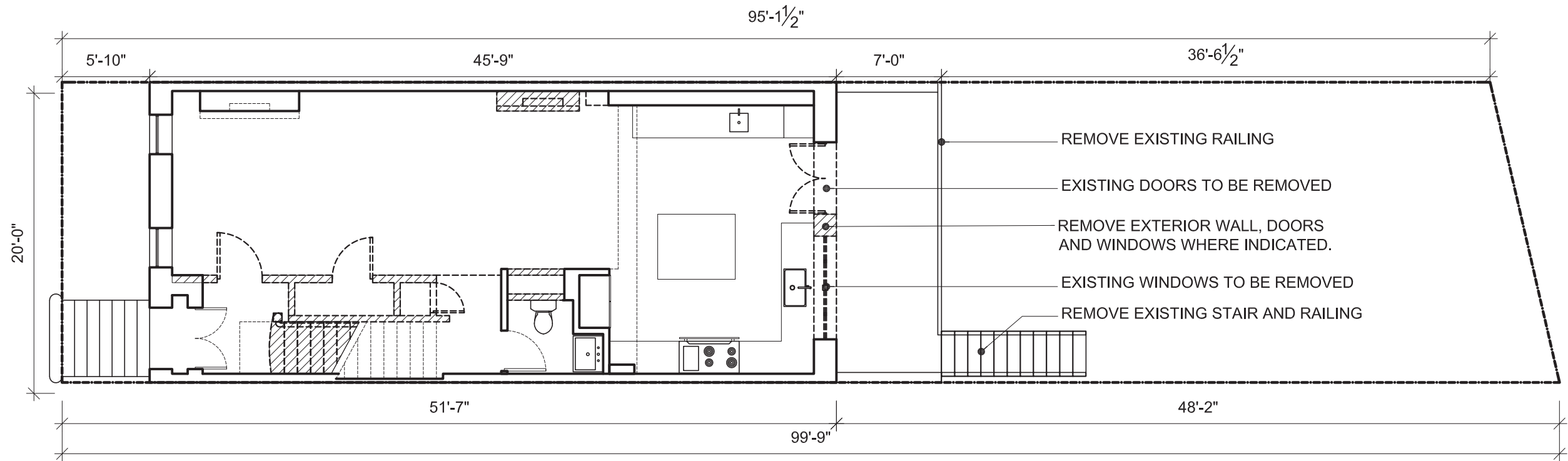

FIRST/PARLOR FLOOR

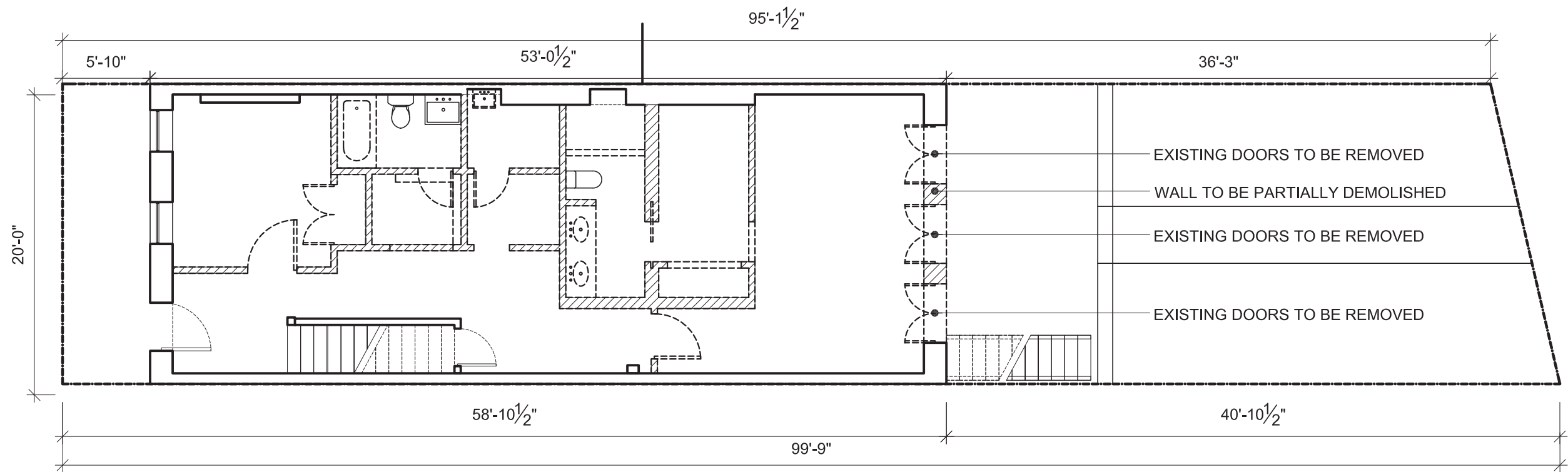

BASEMENT

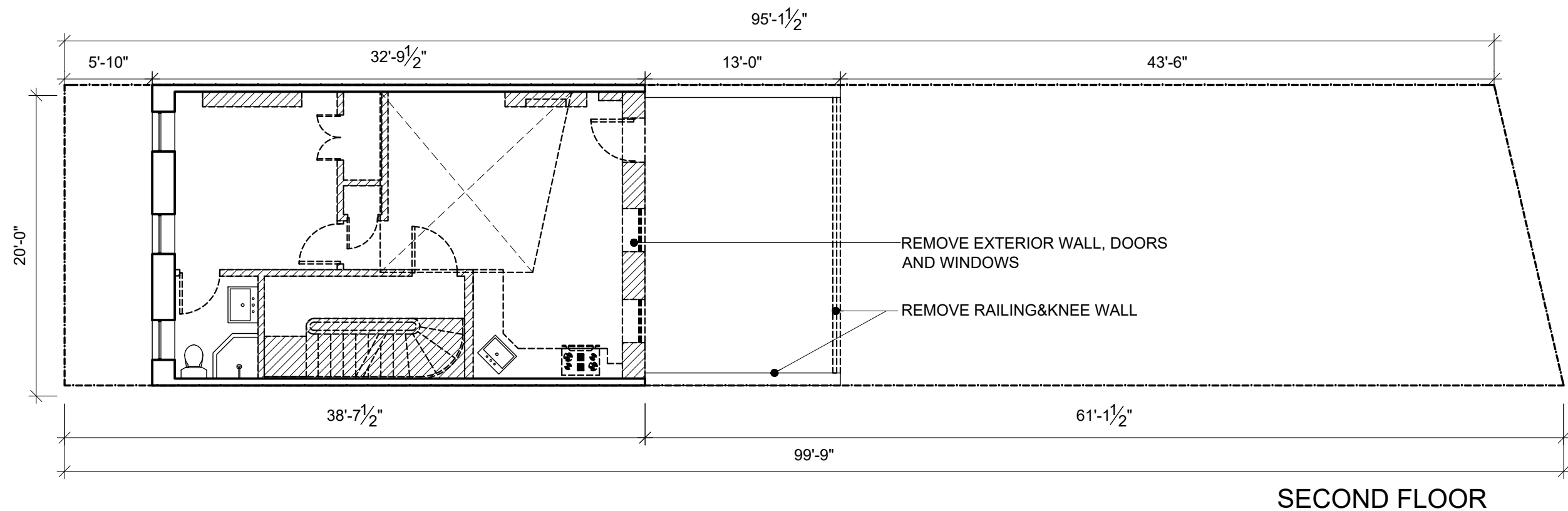
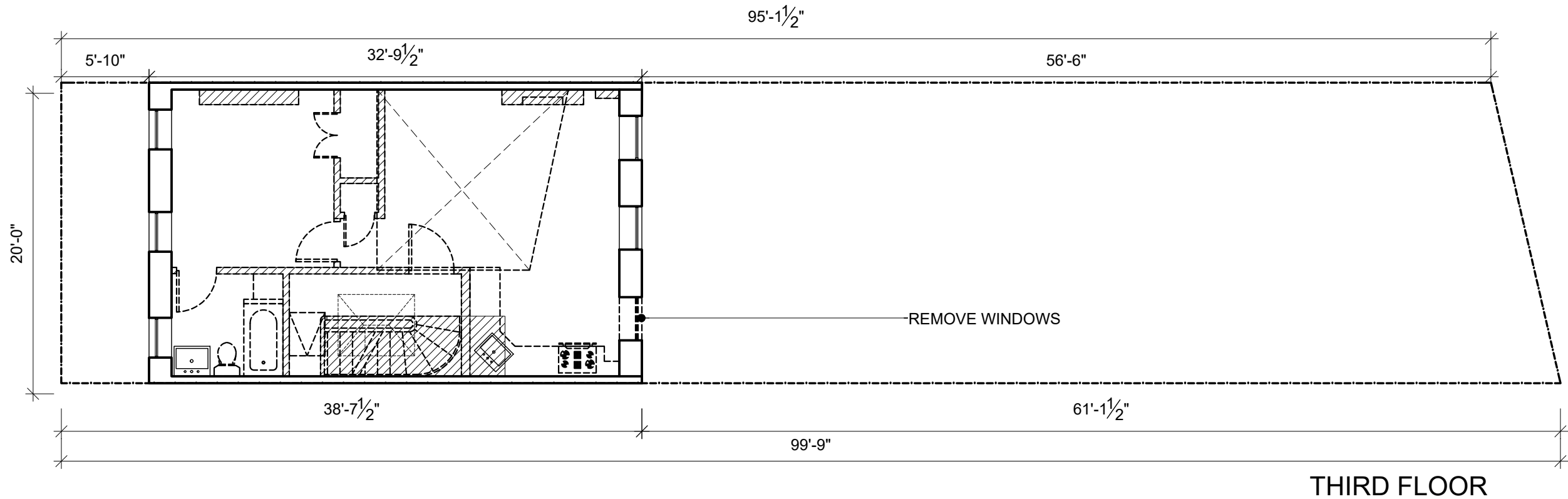

KEY

	EXISTING TO REMAIN
	PROPOSED EXSITING TO BE REMOVED

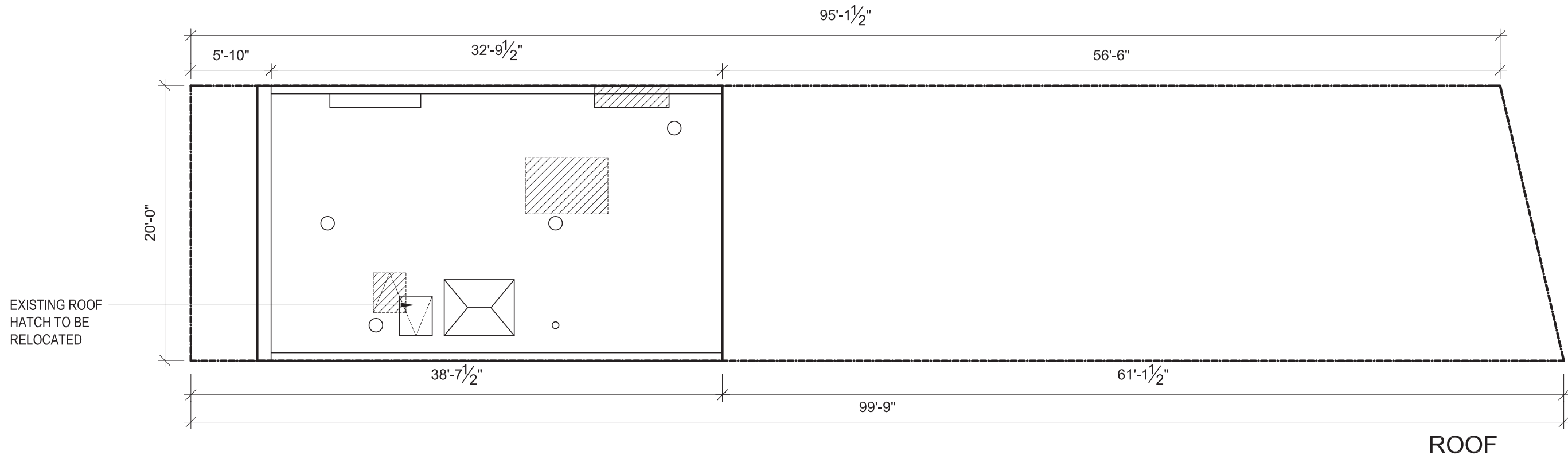

KEY

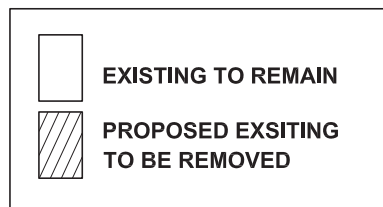

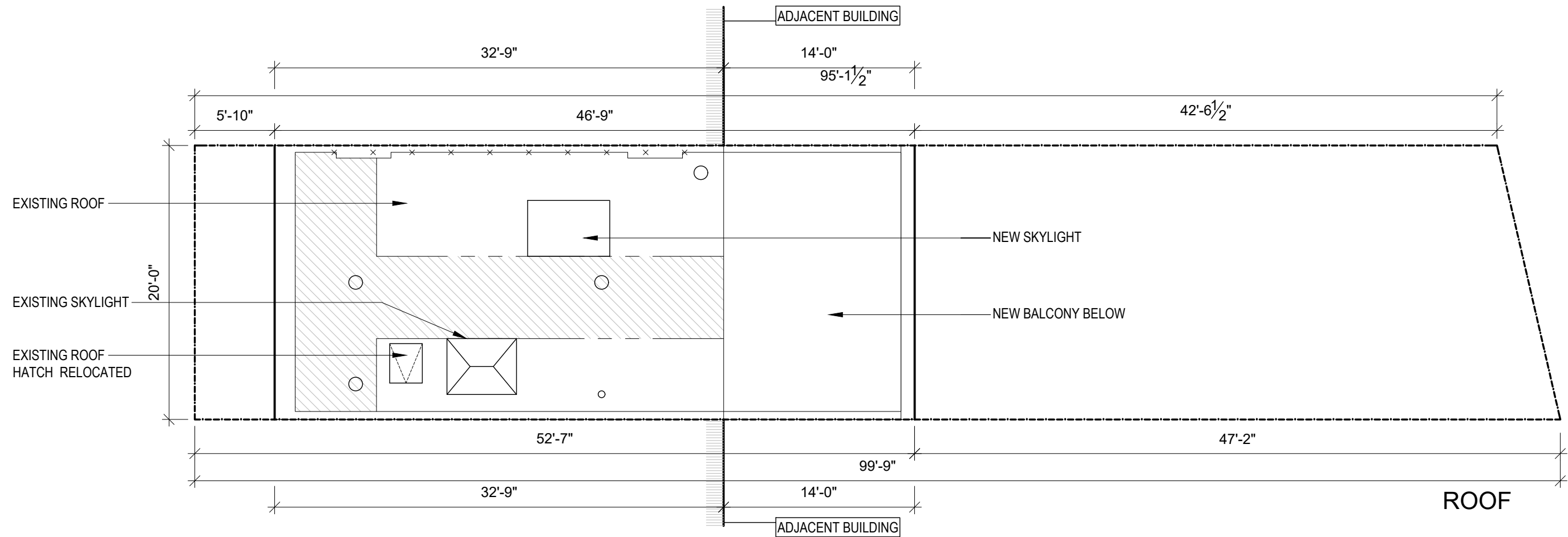

KEY

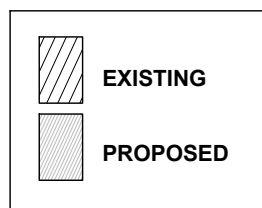

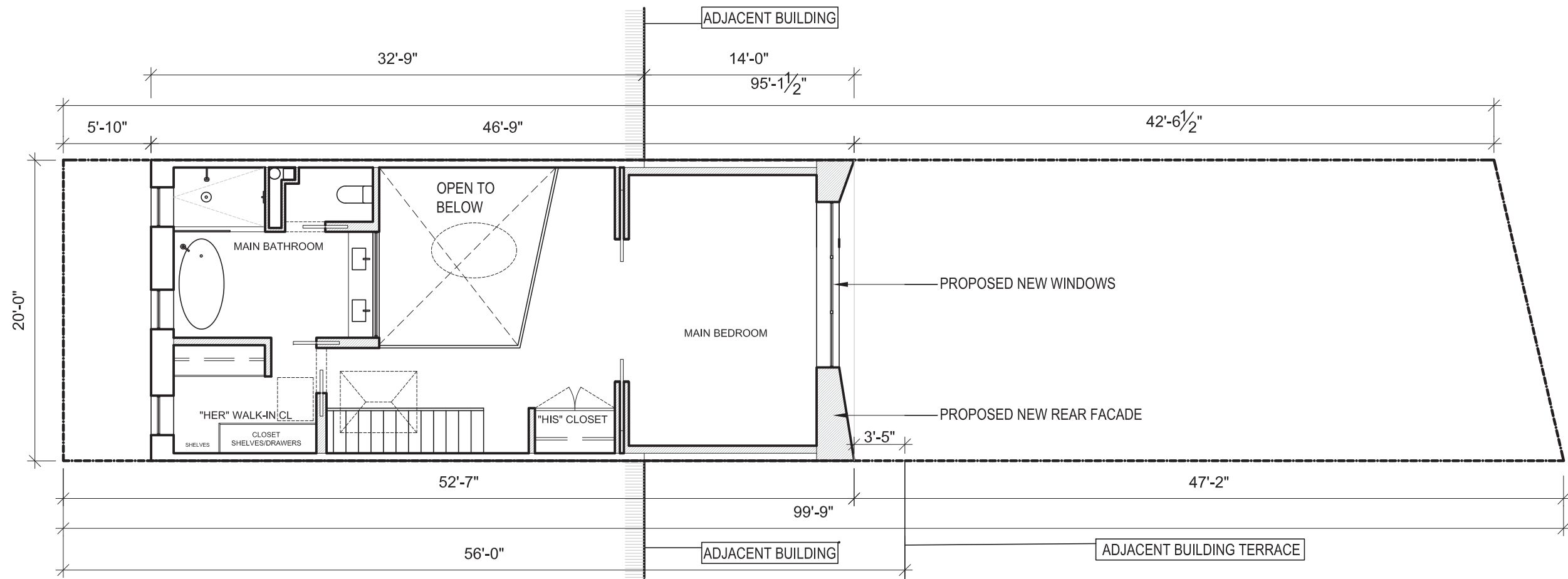

THIRD FLOOR

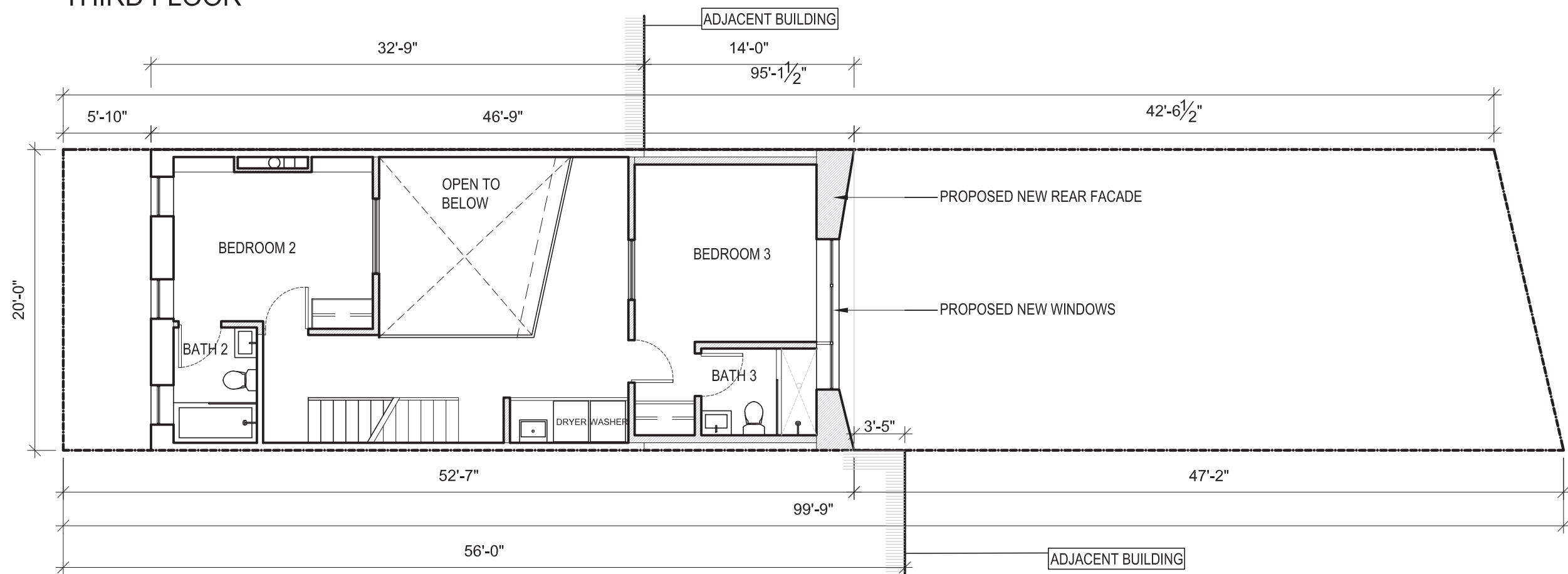

SECOND FLOOR

KEY

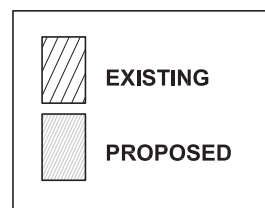

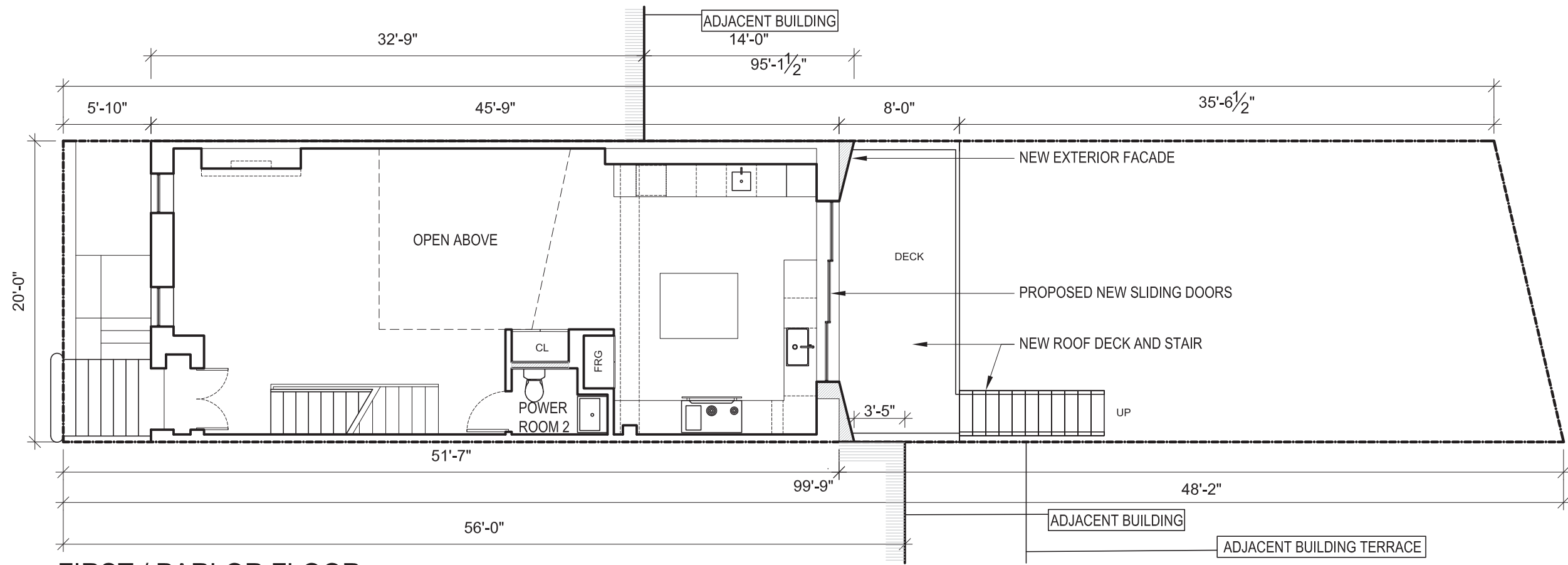

FIRST / PARLOR FLOOR

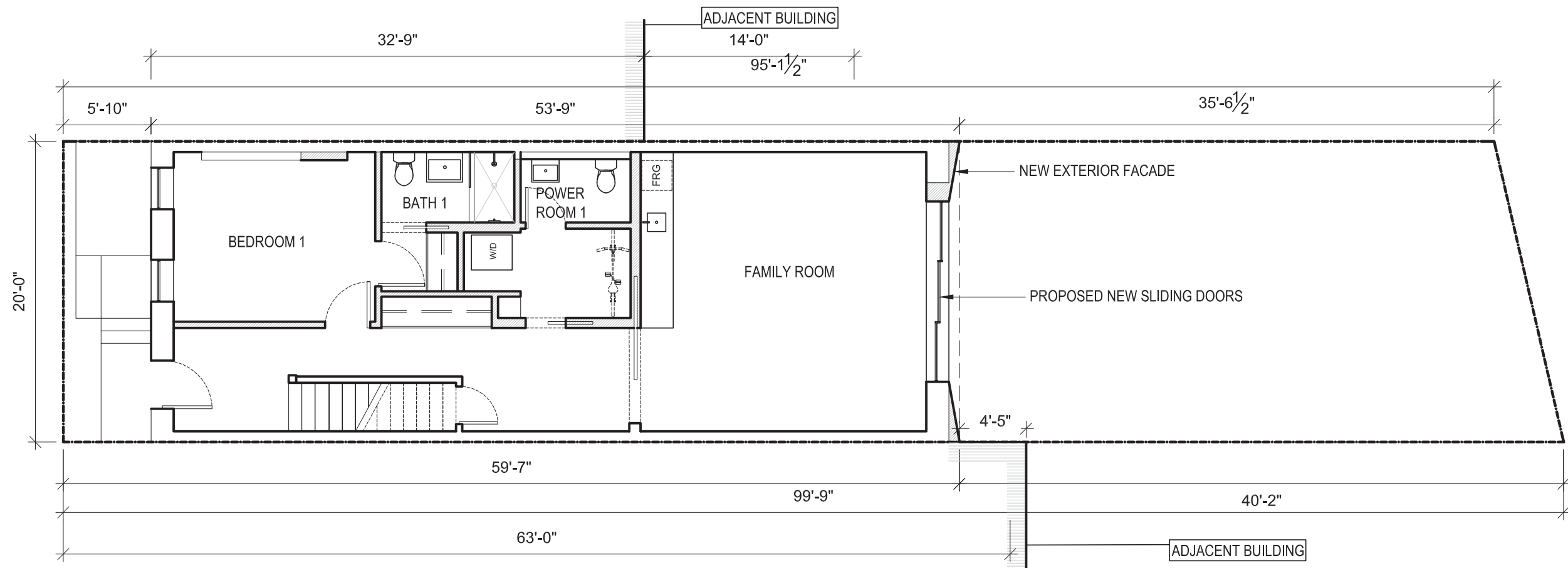

BASEMENT FLOOR

KEY

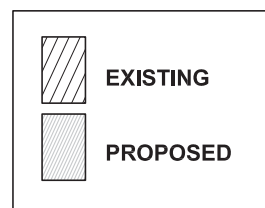

The current proposal is:

Preservation Department – Item 2, LPC-24-08494

17 Fillmore Place – Fillmore Place Historic District
Borough of Brooklyn

Note: this is a Public Meeting item. No public testimony will be received today as the hearing on this item is closed