

ZONING RESOLUTION Web Version

THE CITY OF NEW YORK



THE CITY OF NEW YORK
Michael R. Bloomberg, Mayor

CITY PLANNING COMMISSION
Amanda M. Burden, Director

Article II: Residence District Regulations

Chapter 4 - Bulk Regulations for Community Facility Buildings in
Residence Districts

Effective date of most recently amended section of Article II Chapter 4: 09/30/09

Date of file creation: Web version of Article II Chapter 4: 10/13/09

CITY PLANNING COMMISSION
nyc.gov/planning

DEPARTMENT OF CITY PLANNING
©Copyright 2009 NYC Department of City Planning



12/15/61

Chapter 4

Bulk Regulations for Community Facility Buildings in Residence Districts

12/15/61

24-00

APPLICABILITY, GENERAL PURPOSES AND DEFINITIONS

7/26/01

24-01

Applicability of this Chapter

The #bulk# regulations of this Chapter apply to any #community facility building# or any #building# used partly for a #community facility use# on any #zoning lot# located in any #Residence District# in which such #building# is permitted. As used in this Chapter, the term "any #building#" shall therefore not include a #residential building#, the #bulk# regulations for which are set forth in Article II, Chapter 3. In addition, the #bulk# regulations of this Chapter, or of specified sections thereof, also apply in other provisions of this Resolution where they are incorporated by cross reference.

When two or more #buildings# on a single #zoning lot# are used in any combination for #community facility uses# and #residential# or other permitted #uses#, the regulations set forth in Sections 24-11 to 24-163, inclusive, relating to Floor Area and Lot Coverage Regulations, shall apply as if such #buildings# were a single #building# used partly for #community facility use#.

However, in R3A, R3X, R3-1, R4A, R4-1, R4B or R5B Districts, except for #community facility uses# that have received tax-exempt status from the New York City Department of Finance, or its successor, pursuant to Section 420 of the New York State Real Property Tax Law, or its successor, the #bulk# regulations of this Chapter shall apply only to a #building# that is used entirely for #community facility uses# and the #bulk# regulations of Article II, Chapter 3, shall apply to any #building# that is used partly for #community facility use# and partly for #residential use# except as otherwise permitted in Section 24-04 (Modifications of Bulk Regulations in Certain Districts).

Existing #buildings or other structures# that do not comply with one or more of the applicable #bulk# regulations are #non-complying buildings or other structures# and are subject to the regulations set forth in Article V, Chapter 4.

Special regulations applying to #large-scale community facility developments# or to #community facility uses# in #large-scale residential developments# are set forth in Article VII, Chapter 8.

Special regulations applying only in Special Purpose Districts are set forth in Articles VIII, IX, X, XI and XII.

Special regulations applying in the #waterfront area# are set forth in Article VI, Chapter 2.

9/30/09

24-011

Quality Housing Program

In R6A, R6B, R7A, R7B, R7D, R7X, R8A, R8B, R8X, R9A, R9D, R9X, R10A or R10X Districts, any #residential# portion of a #building# shall comply with all of the regulations of Article II, Chapter 8 (Quality Housing Program), and the entire #building# shall comply with the applicable provisions of Article II, Chapter 8. In R5D Districts, certain provisions of Article II, Chapter 8, shall apply as set forth in Section 28-01 (Applicability of this Chapter).

In other R6, R7, R8, R9 or R10 Districts, the #bulk# regulations applicable to Quality Housing #developments# may, as an alternative, be applied to the #residential# portion of a #building# under the same conditions set forth in Section 23-011, provided that:

- (a) the entire #building# is #developed# pursuant to the #bulk# regulations in Article II, Chapter 4, for #buildings# in which the #residential# portion is #developed#, or #enlarged# where permitted, pursuant to the Quality Housing Program; and
- (b) the entire #building# complies with the applicable provisions of Article II, Chapter 8.

In R6 or R7 Districts within the study areas set forth in Section 23-011 (Quality Housing Program), the #floor area ratios# and the density requirements applicable to Quality Housing #developments#

shall not apply to any #zoning lot# occupied as of August 14, 1987, by a #single-#, #two-# or three- #family detached# or #semi-detached residence# where 70 percent or more of the aggregate length of the blockfronts in #residential use# on both sides of the #street# facing each other are occupied by such #residences#. For any #development# on such #zoning lot#, the #floor area ratio# and #lot area per room# or #rooming unit# requirement of the underlying district shall apply. On a #narrow street# that intersects with a #wide street#, the 70 percent #residential use# requirement on a #narrow street# shall be measured from a distance of 100 feet from its intersection with a #wide street#.

3/1/06

24-012
Harassment

Within the Greenpoint-Williamsburg #anti-harassment areas# set forth in Section 23-013, the provisions of Section 23-013 shall apply to any #zoning lot# containing a #building# used partly for a #residential use#.

8/14/87

24-02
General Purposes of Community Facility Bulk Regulations

The following bulk regulations are adopted in order to protect residential areas against congestion and to encourage the development of desirable and stable residential neighborhoods. In order to achieve these purposes, a direct control of the physical volume of buildings and their degree of lot coverage is established.

8/18/77

24-03
Definitions

Words in italics are defined in Section 12-10 or, if applicable exclusively to this Section, in this Section.

12/5/90

24-04

Modification of Bulk Regulations in Certain Districts

R3-1 R3A R3X R4-1 R4A R4B R5B

In the districts indicated, the City Planning Commission may, upon application, authorize #developments# pursuant to the #bulk# regulations of this Chapter, provided that the Commission finds that:

- (a) the design of the #development# ensures adequate separation of #uses# and sufficient independent access to each #use#; and
- (b) the #floor area# designated for #community facility use# is designed in a manner that is consistent with such #use# and physically distinguishes such space from that designated for #residential use#.

The Commission may prescribe additional safeguards to prevent the conversion of such #community facility use# to #residential use#.

Applications for authorizations shall be referred to the affected Community Board for a period of at least 30 days for comment. The City Planning Commission shall grant in whole or in part or deny the application within 60 days of the completion of the Community Board review period.

4/30/08

24-05

Street Tree Planting

R1 R2 R3 R4 R5 R6 R7 R8 R9 R10

In all districts, as indicated, the following shall provide #street# trees in accordance with Section 26-41 (Street Tree Planting):

- (a) #developments#, or #enlargements# that increase the #floor area# on a #zoning lot# by 20 percent or more. However, #street# trees shall not be required for #enlargements# of #single-# or #two-family residences#, except as provided in paragraphs (b) and (c) of this Section;

- (b) #enlargements# of #single-# or #two-family residences# by 20 percent or more within the following special purpose districts:
- #Special Bay Ridge District#;
 - #Special Clinton District#;
 - #Special Downtown Brooklyn District#;
 - #Special Downtown Jamaica District#;
 - #Special Grand Concourse District#;
 - #Special Hillside Preservation District#;
 - #Special Long Island City Mixed Use District#;
 - #Special Ocean Parkway District#;
 - #Special South Richmond Development District#;
- (c) #enlargements#, pursuant to the Quality Housing Program, of #single-# or #two-family residences# by 20 percent or more
- (d) conversions of 20 percent or more of the #floor area# of a non-#residential building# to a #residential use#; or
- (e) construction of a detached garage that is 400 square feet or greater.

4/30/08

24-06

Planting Strips

R1 R2 R3 R4 R5

In the districts indicated, the following shall provide and maintain a planting strip in accordance with Section 26-42:

- (a) #developments#, or #enlargements# that increase the #floor area# on a #zoning lot# by 20 percent or more. However, planting strips shall not be required for #enlargements# of #single-# or #two-family residences#, except as provided in paragraph (b) of this Section;
- (b) #enlargements# of #single-# or #two-family residences# by 20 percent or more within the following special purpose

districts:

#Special Bay Ridge District#;

#Special Downtown Jamaica District#;

#Special Hillside Preservation District#;

#Special Ocean Parkway District#;

#Special South Richmond Development District#;

(c) conversions of 20 percent or more of the #floor area# of a non-#residential building# to a #residential use#; or

(d) construction of a detached garage that is 400 square feet or greater.

12/15/61

24-10

FLOOR AREA AND LOT COVERAGE REGULATIONS

9/30/09

24-11

Maximum Floor Area Ratio and Percentage of Lot Coverage

R1 R2 R3 R4 R5 R6 R7 R8 R9 R10

In all districts, as indicated, for any #community facility building# or any #building# used partly for a #community facility use# on any #zoning lot#, the maximum #floor area ratio# and maximum percent of #lot coverage# shall not exceed the #floor area ratio# and #lot coverage# set forth in the table in this Section, except as otherwise provided in the following Sections:

Section 24-13 (Floor Area Bonus for Deep Front and Wide Side Yards)

Section 24-14 (Floor Area Bonus for a Public Plaza)

Section 24-15 (Floor Area Bonus for Arcades)

Section 24-17 (Special Provisions for Zoning Lots Divided by District Boundaries).

Any given #lot area# shall be counted only once in determining the #floor area ratio#.

Notwithstanding any other provision of this Resolution, the maximum #floor area ratio# in an R9 or R10 District shall not exceed 12.0.

In R9A, R9D, R9X, R10A and R10X Districts, the bonus provisions of Sections 24-14 (Floor Area Bonus for a Public Plaza) and 24-15 (Floor Area Bonus for Arcades) shall not apply and the maximum #floor area ratio# shall not exceed that set forth in the following table:

MAXIMUM FLOOR AREA AND MAXIMUM LOT COVERAGE
 #Lot coverage# (percent of #lot area#)

#Floor Area Ratio#	#Corner Lot#	#Interior Lot# or #Through Lot#	District
1.00	60	55	R1
1.00	60	55	R2
1.00	60	55	R3
2.00	60	55	R4
2.00	60	55	R5 R5A R5B
4.80	70	65	R6
3.00	80	60	R6A
2.00	80	60	R5D R6B
4.80	70	65	R7-1
6.50	70	65	R7-2
4.00	80	65	R7A
3.00	80	65	R7B
4.20	80	65	R7D
5.00	80	70	R7X
6.50	75	65	R8
6.50	80	70	R8A
4.00	80	70	R8B*
6.00	80	70	R8X

10.00	75	65	R9
7.50	80	70	R9A
9.00	80	70	R9D
9.00	80	70	R9X
10.00	75	65	R10
10.00	100	70	R10A R10X

* In R8B Districts, within the boundaries of Community Board 8 in the Borough of Manhattan, the maximum #floor area ratio# on a #zoning lot# containing #community facility uses# exclusively shall not exceed 5.10.

However, the #floor area ratios# listed in this table shall not apply to #community facility uses# that are subject to the provisions of Section 24-111 (Bulk regulations for certain community facility uses).

Within the boundaries of Community District 7 in the Borough of Manhattan, all #developments# or #enlargements# in R10 Districts, except R10A or R10X Districts, shall be limited to a maximum #floor area ratio# of 10.0.

In R9 or R10 Districts, the bonus provisions of Sections 24-14 (Floor Area Bonus for a Public Plaza) or 24-15 (Floor Area Bonus for Arcades) shall apply only to a #development# or #enlargement# with 25 percent or less of its total #floor area# in #residential use#.

9/30/09

24-111

Maximum floor area ratio for certain community facility uses

R1 R2

(a) In the districts indicated, for any #zoning lot# containing #community facility uses# other than those #uses# for which a permit is required pursuant to Sections 22-21 (By the Board of Standards and Appeals), 73-12 (Community Facility Uses in R1 or R2 Districts) and 73-13 (Open Uses in R1 or R2 Districts), or where #bulk# modification is authorized pursuant to Section 74-901 (Bulk modifications for certain community facility uses), the maximum #floor area ratio# shall not exceed the #floor area# permitted for #residential uses# by the applicable district regulations. The provisions

of this paragraph shall not apply to #buildings# for which plans were filed with the Department of Buildings prior to November 15, 1972, including any subsequent amendments thereof.

R3 R4 R5 R6 R7 R8 R9

- (b) In the districts indicated, for any #zoning lot# containing nursing homes, health-related facilities or domiciliary care facilities for adults, each of which have secured certification by the appropriate governmental agency, sanitariums or philanthropic or non-profit institutions with sleeping accommodations as listed in Use Group 3, the allowable #floor area ratio# shall not exceed the maximum #floor area ratio# as set forth in the following table, except where the permissible #floor area ratio# is modified pursuant to Section 74-902 (Bulk modifications for certain community facility uses).

The provisions of paragraph (b) of this Section are not applicable in R8B Districts in Community Board 8 in the Borough of Manhattan.

MAXIMUM FLOOR AREA RATIO FOR
CERTAIN COMMUNITY FACILITIES

District	Maximum #Floor Area Ratio# Permitted
R3	0.50
R4	0.75
R5 R5A R5B	1.27
R5D R6B	2.00
R6	2.43
R6A R7B	3.00
R7	3.44
R7D	4.20
R7X	5.00
R7A R8B	4.00
R8 R8A	6.02
R8X	6.00

R9	7.52
R9A	7.50
R9D	9.00
R9X	9.00

10/17/07

24-112

Existing public amenities for which floor area bonuses have been received

- (a) Elimination or reduction in size of non-bonused open area on a #zoning lot# containing a bonused amenity

In all districts, any existing open area for which a #floor area# bonus has not been utilized that occupies the same #zoning lot# as an existing #publicly accessible open area# or other public amenity, open or enclosed, for which a #floor area# bonus has been utilized, may be reduced in size or eliminated only upon certification of the Chairperson of the City Planning Commission that all bonused amenities comply with the standards under which such #floor area# bonus was granted.

- (b) Nighttime closing of existing public open areas

In all #Residence Districts#, the City Planning Commission may, upon application, authorize the closing during certain nighttime hours of an existing #publicly accessible open area# for which a #floor area# bonus has been received, pursuant to Section 37-727 (Hours of access).

- (c) Elimination or reduction in size of existing public amenities

In all districts, no existing #publicly accessible open area#, #arcade# or other public amenity, open or enclosed, for which a #floor area# bonus has been utilized, shall be eliminated or reduced in size, except by special permit of the City Planning Commission, pursuant to Section 74-761 (Elimination or reduction in size of bonused public amenities).

6/29/94

24-12

Height and Application of Lot Coverage

R3 R4 R5 R6 R7 R8 R9 R10

In the districts indicated, any portion of a #building# located at any height up to but not exceeding 23 feet above #curb level# or #base plane#, where applicable, may be excluded in determining the percentage of #lot coverage# set forth in Section 24-11 (Maximum Floor Area Ratio and Percentage of Lot Coverage). Obstructions permitted under the provisions of Section 24-33 (Permitted Obstructions in Required Yards or Rear Yard Equivalents) shall not be included in #lot coverage#.

6/29/06

24-13

Floor Area Bonus for Deep Front and Wide Side Yards

R3 R4 R5

In the districts indicated, except R5D Districts, the maximum #floor area ratio# set forth in Section 24-11 (Maximum Floor Area Ratio and Percentage of Lot Coverage) may be increased to the #floor area ratio# set forth in the following table, if #yards# are provided as follows:

- (a) on #interior lots#, a #front yard# not less than 30 feet in depth, and a #side yard# not less than 15 feet in width along any #side lot line#;
- (b) on #corner lots#, two #front yards#, each not less than 30 feet in depth;
- (c) on #through lots#, a #front yard# not less than 30 feet in depth along each #front lot line#, provided, however, that if the #rear yard equivalent# required for such #through lot# is provided as set forth in the alternative in paragraph (b) of Section 24-382 (Required rear yard equivalents), at least one #side yard# not less than 30 feet in width shall be provided in addition.

No portion of a #rear yard equivalent# that is also a #front yard# or a #side yard# as provided under this Section may contain any obstructions not permitted in a #front yard# or #side yard# under the provisions of Section 24-33 (Permitted Obstructions in

Required Yards or Rear Yard Equivalents).

However, the provisions of this Section shall not apply to nursing homes, health-related facilities, domiciliary care facilities for adults, sanitariums and philanthropic or non-profit institutions with sleeping accommodations.

Districts	Maximum #Floor Area Ratio# Permitted
R3	1.60
R4	2.40
R5	2.40

10/17/07

24-14

Floor Area Bonus for a Public Plaza

R9 R10

In the districts indicated, for each square foot of a #public plaza#, subject to the provisions of Section 37-70, provided on a #zoning lot#, the total #floor area# permitted on that #zoning lot# under the provisions of Section 24-11 (Maximum Floor Area Ratio and Percentage of Lot Coverage) may be increased by six square feet.

10/17/07

24-15

Floor Area Bonus for Arcades

R9 R10

In the districts indicated, for each square foot of #arcade# provided on a #zoning lot# in accordance with the provisions of Section 37-80 (ARCADES), the total #floor area# permitted on that #zoning lot# under the provisions of Section 24-11 (Maximum Floor Area Ratio and Percentage of Lot Coverage) may be increased by three square feet.

7/26/01

24-16

Special Provisions for Zoning Lots Containing Both Community Facility and Residential Uses

R1 R2 R3 R4 R5 R6 R7 R8 R9 R10

In all districts, as indicated, the provisions of this Section shall apply to any #zoning lot# containing #community facility# and #residential uses#.

7/29/09

24-161

Maximum floor area ratio for zoning lots containing community facility and residential uses

R1 R2 R3-1 R3A R3X R4-1 R4A R4B R5D R6A R6B R7-2 R7A R7B R7D R7X R8 R9 R10

In the districts indicated, for #zoning lots# containing #community facility# and #residential uses#, the maximum #floor area ratio# permitted for a #community facility use# shall be as set forth in Section 24-11, inclusive, and the maximum #floor area ratio# permitted for a #residential use# shall be as set forth in Article II, Chapter 3, provided the total of all such #floor area ratios# does not exceed the greatest #floor area ratio# permitted for any such #use# on the #zoning lot#.

In #Inclusionary Housing designated areas#, except within Waterfront Access Plan BK-1 and in Community District 1, Brooklyn, in R6 Districts without a letter suffix, the maximum #floor area ratio# permitted for #zoning lots# containing #community facility# and #residential uses# shall be the base #floor area ratio# set forth in Section 23-952 for the applicable district. Such base #floor area ratio# may be increased to the maximum #floor area ratio# set forth in such Section only through the provision of #lower income housing# pursuant to Section 23-90 (INCLUSIONARY HOUSING).

6/29/06

24-162

Maximum floor area ratios and special floor area limitations for

zoning lots containing residential and community facility uses in certain districts

R3-2 R4 R5 R6 R7-1

In the districts indicated, except R4A, R4B, R4-1, R5D, R6A and R6B Districts, the provisions of this Section shall apply to any #zoning lot# containing #community facility# and #residential use#.

- (a) For #buildings# containing #residential# and #community facility uses#, where such #buildings# have #floor area ratios# greater than set forth in Column A in the following table, the maximum #floor area ratio# for the #community facility# portions of such #buildings# shall be as set forth in Column B in the table, and the maximum #floor area ratio# for the #residential# portions of such #buildings# shall be as set forth in Article II, Chapter 3, subject to the limitations set forth in paragraph (d) of this Section.

MAXIMUM COMMUNITY FACILITY
FLOOR AREA RATIO FOR CERTAIN BUILDINGS
CONTAINING COMMUNITY FACILITY AND RESIDENTIAL USES

District	COLUMN A	COLUMN B
	#Floor Area Ratio# of #Building#	Maximum #Floor Area Ratio# for #Community Facility Use#
R3-2	.50	.20
R4	.75	.40
R5B	1.25	.40
R5	1.25	.60
R6	2.50	1.00
R7-1	3.50	1.00

- (b) For #buildings# containing #residential# and #community facility uses#, where such #buildings# have #floor area ratios# that do not exceed the applicable #floor area ratios# set forth in Column A in the table in paragraph (a), the maximum #floor area ratio# for the #community facility# portion of such #buildings# shall be as set forth in Section 24-11, inclusive, and the maximum #floor area ratio# for the #residential# portion of such #buildings# shall be as set

forth in Article II, Chapter 3, subject to the limitations set forth in paragraph (d) of this Section.

- (c) For #zoning lots# containing multiple #buildings#, the provisions of this paragraph, (c), shall apply to #buildings# containing only #community facility uses# or only #residential uses#. The maximum #floor area ratio# permitted for a #building# containing only #community facility uses# shall be as set forth in Section 24-11, inclusive, and the maximum #floor area ratio# permitted for a #building# containing only #residential uses# shall be as set forth in Article II, Chapter 3, subject to the limitations set forth in paragraph (d) of this Section.
- (d) The total #floor area ratio# permitted for #community facility use# on the #zoning lot# shall be as set forth in Section 24-11, inclusive, and the total #floor area ratio# permitted for #residential use# on the #zoning lot# shall be as set forth in Article II, Chapter 3, provided the total of all such #floor area ratios# does not exceed the greatest #floor area ratio# permitted for any such #use# on the #zoning lot#.

For the purposes of this Section, a #building segment# may be considered to be a #building#.

6/12/96

24-163

Open space ratio for residential portion

R1 R2 R3 R4 R5 R6 R7 R8 R9

In the districts indicated, the #residential# portion of the #building# shall have a minimum #open space ratio# as required under the provisions of Article II, Chapter 3. For the purposes of this Section:

- (a) the #floor area# counted in determining the #open space ratio# shall be only that #floor area# in the #residential# portion of the #building#;
- (b) the #lot coverage# of the #residential# portion of the #building# shall be deemed to be that portion of the #zoning lot# which, when viewed directly from above, would be covered by the #residential# portion of the #building# at any level; and

(c) the applicable #height factor#, if the maximum permitted #residential floor area ratio# is less than the total #floor area ratio# permitted for such #building#, shall be the #height factor# of the #residential# portion of the #building#.

9/30/09

24-164

Location of open space for residential portion

R1 R2 R3 R4 R5 R6 R7 R8 R9

(a) In the districts indicated, the #open space# required for the #residential# portion of the #building# under the provisions of Article II, Chapter 3, may be at a level higher than 23 feet above #curb level#. Such #open space# may be provided at ground floor level or upon the roof of the #community facility# portion of such #building#, provided that the level of any #open space# may not be higher than two and one half feet below the sill level of any #legally required window# opening on such roof area, in the #residential# portion of such #building#. #Open space# located on the roof of a separate #community facility building# may not be at a level higher than 23 feet above #curb level#.

R6A R6B R7A R7B R7D R7X R8A R8B R8X R9A R9D R9X R10A R10X

(b) In the districts indicated, and for #buildings# in which the #residential# portion is #developed#, or #enlarged# where permitted, pursuant to the Quality Housing Program in other R6, R7, R8, R9 or R10 Districts, the provisions of Section 28-30 (RECREATION SPACE AND PLANTING AREAS) shall apply.

7/26/01

24-165

Balconies

R3 R4 R5 R6 R7 R8 R9 R10

In all districts, as indicated, the regulations set forth in Section 23-13 (Balconies) shall apply to the #residential# portion of a #building# used partly for #residential use# and partly for #community facility use# or to any portion of a

#building# used for living or sleeping accommodations.

6/12/96

24-17

Special Provisions for Zoning Lots Divided by District Boundaries

R1 R2 R3 R4 R5 R6 R7 R8 R9 R10

In all districts, as indicated, whenever a #zoning lot# is divided by a boundary between districts or is subject to other regulations resulting in different maximum #floor area ratios#, different minimum #open space ratios#, different maximum percentages of #lot coverage#, or #open space ratios# and #lot coverages#, on portions of the #zoning lot#, the provisions set forth in Article VII, Chapter 7 shall apply.

7/26/01

24-20

APPLICABILITY OF DENSITY REGULATIONS TO ZONING LOTS CONTAINING BOTH RESIDENTIAL AND COMMUNITY FACILITY USES

In all districts, the maximum number of #dwelling units# or #rooming units# on a #zoning lot# containing both #community facility# and #residential uses# shall equal the maximum #residential floor area# permitted on such #zoning lot# determined in accordance with the provisions set forth in Section 24-16 (Special Provisions for Zoning Lots Containing Both Community Facility and Residential Uses) divided by the applicable factor in Section 23-20 (DENSITY REGULATIONS).

7/26/01

24-21

Special Provisions for Zoning Lots Divided by District Boundaries

R1 R2 R3 R4 R5 R6 R7 R8 R9 R10

In all districts, as indicated, whenever a #zoning lot# is divided by a boundary between districts or is subject to other regulations resulting in different #lot area# requirements on portions of the #zoning lot#, the provisions set forth in Article VII, Chapter 7 shall apply.

12/15/61

24-30

YARD REGULATIONS

General Provisions

12/15/61

24-31

Level of Yards

In all #Residence Districts#, the level of a #yard# or of a #rear yard equivalent# shall not be higher than #curb level#, except that natural grade level need not be disturbed in order to comply with this requirement. No #building or other structure# shall be erected above ground level in any required #yard# or #rear yard equivalent#, except as otherwise provided in Section 24-33 (Permitted Obstructions in Required Yards or Rear Yard Equivalents).

12/15/61

24-32

Measurement of Yard Width or Depth

In all #Residence Districts#, the width or depth of a #yard# or #rear yard equivalent# shall be measured perpendicular to #lot lines#.

4/22/09

24-33

Permitted Obstructions in Required Yards or Rear Yard Equivalents

In all #Residence Districts#, the following shall not be considered obstructions when located within a required #yard# or #rear yard equivalent#:

(a) In any #yard# or #rear yard equivalent#:

Arbors or trellises;

Awnings or canopies;

Chimneys, projecting not more than three feet into, and not exceeding two percent of the area of, the required #yard# or #rear yard equivalent#;

Eaves, gutters or downspouts, projecting into such #yard# or #rear yard equivalent# not more than 16 inches or 20 percent of the width of such #yard# or #rear yard equivalent#, whichever is the lesser distance;

Fences;

Flagpoles;

Parking spaces for automobiles or bicycles, off-street, open, #accessory#;

Steps;

Terraces or porches, open;

Walls, not exceeding eight feet in height and not roofed or part of a #building#;

(b) In any #rear yard# or #rear yard equivalent#:

Balconies, unenclosed, subject to the provisions of Section 24-165;

Breezeways;

Any #building# or portion of a #building# used for #community facility uses#, including #accessory# parking spaces for bicycles within such #building#, provided that the height of such #building# shall not exceed one #story#, nor in any event 23 feet above #curb level#, and further provided that the area within such #building# dedicated to #accessory# parking spaces for bicycles shall not exceed the area permitted to be excluded from #floor area#, pursuant to Section 25-85 (Floor Area Exemption). However, the following shall not be permitted obstructions:

- (1) in all #residence districts#, any portion of a #building# containing rooms used for living or sleeping purposes, other than a room in a hospital used for the care or treatment of patients;

- (2) in R1, R2, R3A, R3X, R3-1, R4A, R4B or R4-1 Districts, any portion of a #building# used for any #community facility use#;
- (3) in all #residence districts# not listed in paragraph (b)(2) of this Section, beyond one hundred feet of a #wide street#, any portion of a #building# used for a #community facility use# other than a #school#, house of worship, college or university, or hospital and related facilities;

Fire escapes;

Greenhouses, #accessory#, non-commercial, limited to one #story# or 14 feet in height above natural grade level, whichever is less, and limited to an area not exceeding 25 percent of a required #rear yard# or #rear yard equivalent# on a #zoning lot#;

Parking spaces, off-street, #accessory# to a #community facility building# or a #building# used partly for #community facility uses#, provided that the height of an #accessory building# used for such purposes shall not exceed 14 feet above #curb level#. However, such #accessory building# shall not be a permitted obstruction in R1, R2, R3A, R3X, R3-1, R4A, R4B or R4-1 Districts;

Recreation or drying yard equipment;

Sheds, tool rooms or other similar #accessory buildings or other structures# for domestic or agricultural storage, with a height not exceeding 10 feet above the level of the #rear yard# or #rear yard equivalent#;

Water-conserving devices required in connection with air conditioning or refrigeration systems in #buildings# existing prior to May 20, 1966, if located not less than 8 feet from any #lot line#.

However, no portion of a #rear yard equivalent# which is also a required #front yard# or required #side yard# may contain any obstructions not permitted in such #front yard# or #side yard#.

Basic Regulations

6/29/06

24-34

Minimum Required Front Yards

R1 R2 R3 R4 R5

In the districts indicated, #front yards# shall be provided as set forth in the following table, except that for a #corner lot# in an R1-2 District, one #front yard# may have a depth of 15 feet.

#Front Yard# (in feet)	District
20	R1
15	R2 R3 R4
10	R5
5*	R5D

* In R5D Districts, the provisions set forth in Section 23-45 (Minimum Required Front Yards) shall apply.

6/29/06

24-35

Minimum Required Side Yards

R1 R2 R3 R4 R5

- (a) In the districts indicated, if a #building# used for #community facility use# has an #aggregate width of street walls# equal to 80 feet or less, two #side yards# shall be provided, each with a minimum required width of eight feet. If such #building# has an #aggregate width of street walls# equal to more than 80 feet, two #side yards# shall be provided, each equal to not less than 10 percent of the #aggregate width of street walls#. The provisions of this paragraph, (a), shall not apply in R5D Districts. In lieu thereof, the #side yard# regulations set forth in Sections 23-461 and 23-462, as applicable, shall apply.

R6 R7 R8 R9 R10

- (b) In the districts indicated, no #side yards# are required. However, if any open area extending along a #side lot line# is provided at any level, it shall be at least eight feet wide.

9/30/09

24-351

Special provisions applying along district boundaries

R6 R7 R8 R9 R10

In the districts indicated, if the boundary of an adjoining R1, R2, R3, R4 or R5 District coincides with a #side lot line# of a #zoning lot#, a #side yard# at least eight feet wide shall be provided along such boundary within the districts indicated. In addition, the requirements for R6B Districts in Section 23-633 (Street wall location and height and setback regulations in certain districts) shall apply to any portion of a #building# located within 25 feet of the boundary of an R1, R2, R3, R4, R5 or R6B District if the #building# that contains such portion is:

- (a) within an R6A, R7A, R7B, R7D, R7X, R8A, R8B, R8X, R9A, R9D, R9X, R10A or R10X District; or
- (b) within an R6, R7, R8, R9 or R10 District, without a letter suffix, and any portion of the #zoning lot# is #developed# pursuant to the Quality Housing Program.

Rear Yards

4/30/08

24-36

Minimum Required Rear Yards

R1 R2 R3 R4 R5 R6 R7 R8 R9 R10

In all districts, as indicated, a #rear yard# with a depth of not less than 30 feet shall be provided at every #rear lot line# on any #zoning lot# except as otherwise provided in Sections 24-37 (Special Provisions for Shallow Interior Lots), 24-38 (Special Provisions for Through Lots) or 24-39 (Other Special Provisions for Rear Yards). #Rear yards# shall also be provided along portions of #side lot lines# as set forth in Section 24-361 (Beyond one hundred feet of a street line).

4/30/08

24-361

Beyond one hundred feet of a street line

R1 R2 R3 R4 R5 R6 R7 R8 R9 R10

In all districts, as indicated, for #corner lots#, and for #zoning lots# that are bounded by two or more #streets# that are neither #corner lots# nor #through lots#, the portion of a #side lot line# beyond 100 feet of the #street line# that it intersects shall be considered a #rear lot line# and the following rules shall apply along such #rear lot line#:

- (a) In all districts, a #rear yard# with a minimum depth of 30 feet shall be provided where such #rear lot line# coincides with a #rear lot line# of an adjoining #zoning lot#.

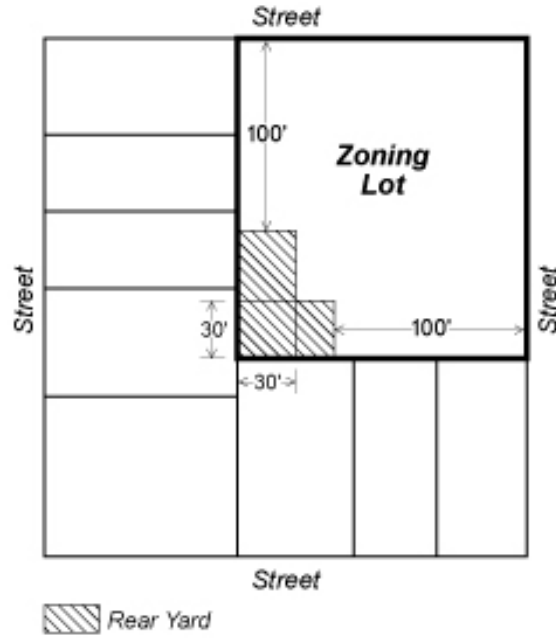

CORNER LOT

- (b) In R1 through R5 Districts, a #rear yard# with a minimum depth of eight feet shall be provided where such #rear lot line# coincides with a #side lot line# of an adjoining #zoning lot#.

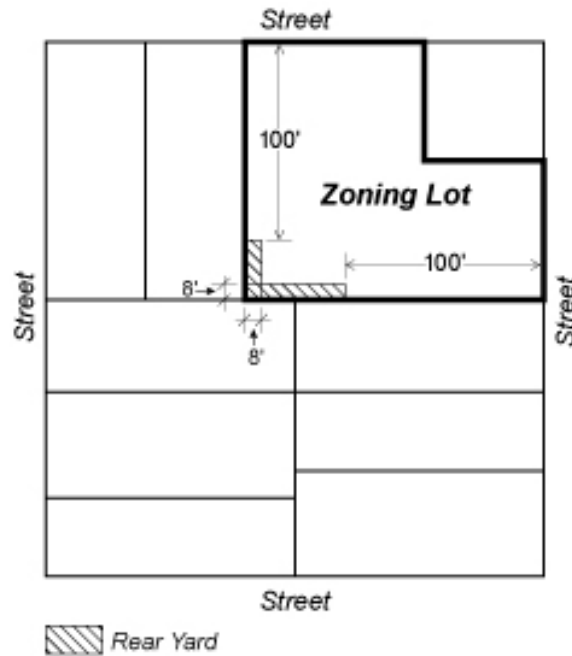

ZONING LOT BOUNDED BY TWO OR MORE STREETS
(NEITHER A CORNER LOT NOR A THROUGH LOT)

- (c) In R6 through R10 Districts, no #rear yard# shall be required where such #rear lot line# coincides with a #side lot line# of an adjoining #zoning lot#.

2/20/64

24-37

Special Provisions for Shallow Interior Lots

R3 R4 R5 R6 R7 R8 R9 R10

In the districts indicated, if an #interior lot# consists entirely of a tract of land:

- (a) which was owned separately and individually from all other adjoining tracts of land, both on December 15, 1961 and on the date of application for a building permit; and

(b) which is less than 70 feet deep at any point;

the depth of a required #rear yard# for such #interior lot# may be reduced by one foot for each foot by which the maximum depth of such #zoning lot# is less than 70 feet. On any #interior lot# with a maximum depth of 50 feet or less, the minimum depth of a required #rear yard# shall be ten feet.

6/29/94

24-38

Special Provisions for Through Lots

R1 R2 R3 R4 R5 R6 R7 R8 R9 R10

In all districts, as indicated, the regulations of this Section shall apply to all #through lots#. In the case of a #zoning lot# occupying an entire #block#, no #rear yard# or #rear yard equivalent# shall be required.

9/30/09

24-381

Excepted through lots

R1 R2 R3 R4 R5 R6 R7 R8 R9 R10

(a) In all districts, as indicated, no #rear yard# regulations shall apply to any #through lots# that extend less than 110 feet in maximum depth from #street# to #street#.

R5D R6A R6B R7A R7B R7D R7X R8A R8B R8X R9A R9D R9X R10A R10X

(b) In the districts indicated, and in other R6, R7, R8, R9 and R10 Districts where the #residential# portion of a #building# is #developed# or #enlarged# pursuant to the Quality Housing Program, no #rear yard# regulations shall apply to any #zoning lot# that includes a #through lot# portion that is contiguous on one side to two #corner lot# portions, and such #zoning lot# occupies the entire #block# frontage of a #street#.

9/30/09

24-382

Required rear yard equivalents

R1 R2 R3 R4 R5 R6 R7 R8 R9 R10

In all districts, as indicated, on any #through lot# 110 feet or more in maximum depth from #street# to #street#, one of the following #rear yard equivalents# shall be provided:

- (a) an open area with a minimum depth of 60 feet midway (or within five feet of being midway) between the two #street lines# upon which such #through lot# fronts;
- (b) two open areas, each adjoining and extending along the full length of a #street line#, and each with a minimum depth of 30 feet measured from such #street line#, except the depth of such required open area along one #street line# may be decreased provided that:
 - (1) a corresponding increase in the depth of the open area along the other #street line# is made; and
 - (2) any required front setback areas are maintained; or
- (c) an open area adjoining and extending along the full length of each #side lot line#, with a minimum width of 30 feet measured from each such #side lot line#.

However, in R5D, R6A, R6B, R7A, R7B, R7D, R7X, R8A, R8B, R8X, R9A, R9D, R9X, R10A and R10X Districts, and in other R6 through R10 Districts where the #residential# portion of a #building# is #developed# or #enlarged# pursuant to the Quality Housing Program, on any #through lot# at least 180 feet in depth from #street to street#, a #rear yard equivalent# shall be provided only as set forth in paragraph (a) of this Section.

Any such #rear yard equivalent# shall be unobstructed from its lowest level to the sky, except as provided in Section 24-33 (Permitted Obstructions in Required Yards or Rear Yard Equivalents).

12/15/61

24-39

Other Special Provisions for Rear Yards

R1 R2 R3 R4 R5 R6 R7 R8 R9 R10

In all districts, as indicated, the #rear yard# requirements set forth in Section 24-36 (Minimum Required Rear Yards) shall be modified, as set forth in this Section, inclusive.

4/30/08

24-391

Within one hundred feet of corners

R6 R7 R8 R9 R10

In the districts indicated, no #rear yard# shall be required within 100 feet of the point of intersection of two #street lines# intersecting at an angle of 135 degrees or less.

4/30/08

24-392

Along short dimension of block

R6 R7 R8 R9 R10

In the districts indicated, whenever a #front lot line# of a #zoning lot# coincides with all or part of a #street line# measuring less than 220 feet in length between two intersecting #streets#, no #rear yard# shall be required within 100 feet of such #front lot line#.

4/30/08

24-393

For zoning lots with multiple rear lot lines

R1 R2 R3 R4 R5 R6 R7 R8 R9 R10

In all districts, as indicated, for #zoning lots# with multiple #rear lot lines#, if a #rear yard# extends from a #rear lot line# away from the #street line# which is used to determine such #rear lot line#, the following rules shall apply along such #rear lot line#:

- (a) In all districts, a #rear yard# with a minimum depth of 30 feet shall be provided where such #rear lot line# coincides with a #rear lot line# of an adjoining #zoning lot#.

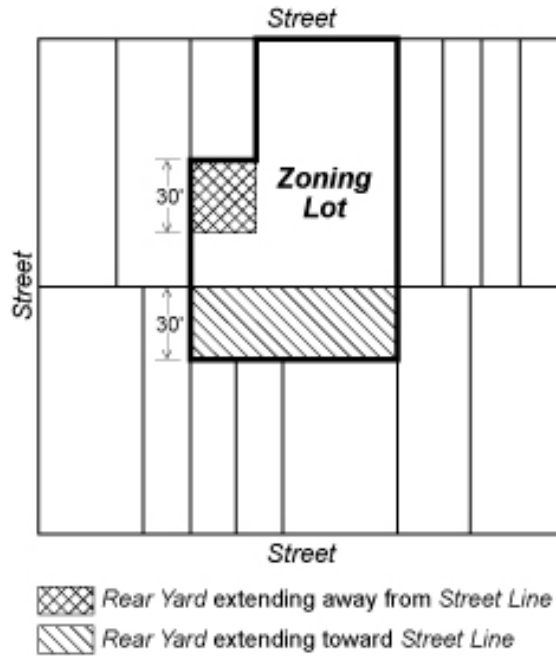

- (b) In R1 through R5 Districts, a #rear yard# with a minimum depth of eight feet shall be provided where such #rear lot line# coincides with a #side lot line# of an adjoining #zoning lot#.

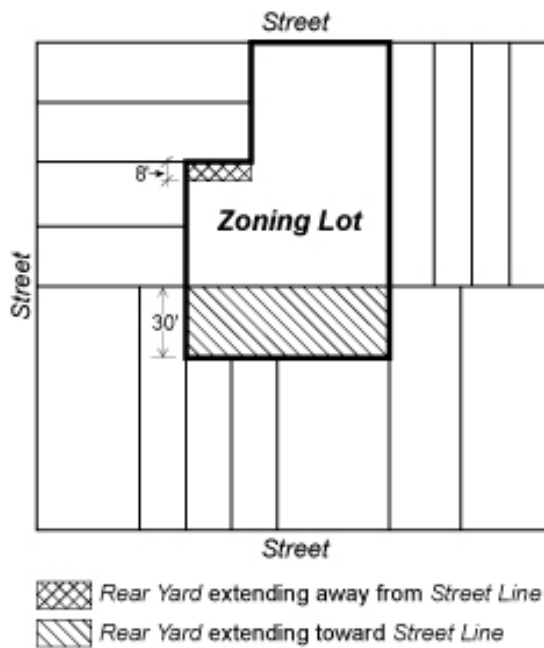

- (c) In R6 through R10 Districts, no #rear yard# shall be required where such #rear lot line# coincides with a #side lot line# of an adjoining #zoning lot#.
- (d) In all districts, for portions of #through lots# that have multiple #rear lot lines# and such portions are not subject to #interior lot# regulations, the #street line# bounding the #zoning lot# closest to such #rear lot line# shall be used to determine compliance with this Section.

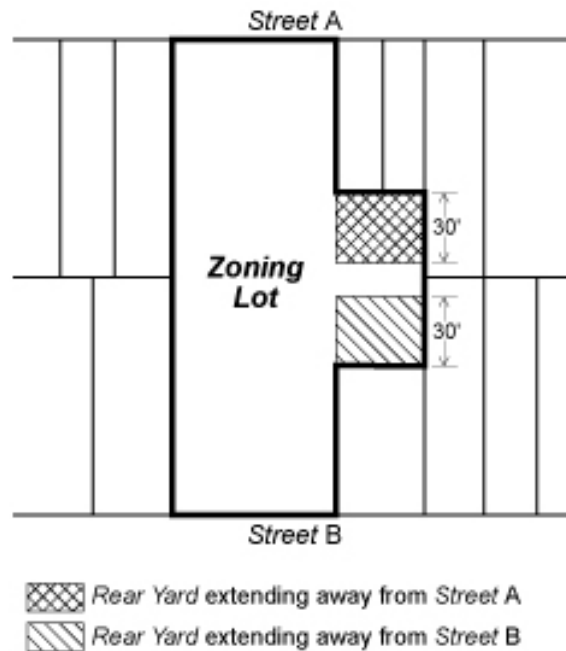

All Yards

8/14/87

24-40

SPECIAL PROVISIONS FOR ZONING LOTS DIVIDED BY DISTRICT BOUNDARIES

R1 R2 R3 R4 R5 R6 R7 R8 R9 R10

In all districts, as indicated, whenever a #zoning lot# is divided by a boundary between districts or is subject to other regulations resulting in different #yard# regulations on portions of the #zoning lot#, the provisions set forth in Article VII, Chapter 7, shall apply.

4/30/08

24-41

Modifications of Rear Yard Regulations

R1 R2 R3 R4 R5 R6 R7 R8 R9 R10

In all districts, as indicated, the regulations set forth in Section 24-393 (For zoning lots with multiple rear lot lines) may be modified in accordance with the provisions of Section 73-69 (Rear Yard Modifications).

12/15/61

24-50

HEIGHT AND SETBACK REGULATIONS

9/9/04

24-51

Permitted Obstructions

In all #Residence Districts#, the following shall not be considered obstructions and may thus penetrate a maximum height limit or #front# or #rear sky exposure planes# set forth in Sections 24-52 (Maximum Height of Walls and Required Setbacks), 24-53 (Alternate Front Setbacks) or 24-591 (Limited Height Districts):

- (a) Balconies, unenclosed, subject to the provisions of Section 24-165;
- (b) Chimneys or flues, with a total width not exceeding 10 percent of the #aggregate width of street walls# of a #building# at any level;
- (c) Elevator or stair bulkheads, roof water tanks or cooling towers (including enclosures), each having an #aggregate width of street walls# equal to not more than 30 feet. However, the product, in square feet, of the #aggregate width of street walls# of such obstructions facing each #street# frontage, times their average height, in feet, shall not exceed a figure equal to four times the width, in feet, of the #street wall# of the #building# facing such frontage;

- (d) Flagpoles or aerials;
- (e) House of worship towers, ornamental, having no #floor area# in portion of tower penetrating such height limit or #sky exposure plane#;
- (f) Parapet walls, not more than four feet high;
- (g) Spires or belfries;
- (h) Wire, chain link or other transparent fences.

Building columns having an aggregate width equal to not more than 20 percent of the #aggregate width of street walls# of a #building# are a permitted obstruction, to a depth not exceeding 12 inches, in an #initial setback distance#, optional front open area, or any other required setback distance or open area set forth in Sections 24-52, 24-53, or 24-54 (Tower Regulations).

Basic Regulations

6/29/94

24-52

Maximum Height of Walls and Required Setbacks

R1 R2 R3 R4 R5 R6 R7 R8 R9 R10

In all districts, as indicated, the maximum height of a front wall or of any other portion of a #building or other structure# shall be as set forth in this Section, except as otherwise provided in Section 24-51 (Permitted Obstructions), Section 24-53 (Alternate Front Setbacks), Section 24-54 (Tower Regulations) or 23-692 (Height limitations for narrow buildings or enlargements).

6/29/06

24-521

Front setbacks in districts where front yards are required

R1 R2 R3 R4 R5

In the districts indicated, where #front yards# are required, the front wall or any other portion of a #building or other structure# shall not penetrate the #sky exposure plane# set forth

in the following table:

MAXIMUM HEIGHT OF FRONT WALL AND
REQUIRED FRONT SETBACKS

Height above #Front Yard Line# (in feet)	#Sky Exposure Plane#				District
	Slope over #Zoning Lot# (expressed as a ratio of vertical distance to horizontal distance)				
	On #Narrow Street#		On #Wide Street#		
	Vertical Distance	Horizontal Distance	Vertical Distance	Horizontal Distance	
25	1 to 1	1	1 to 1	1	R1 R2 R3
35	1 to 1	1	1 to 1	1	R4 R5

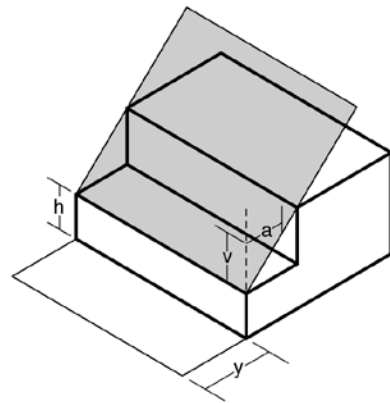

a - Horizontal distance
h - Height of sky exposure plane
above front yard line level
v - Vertical distance
y - Depth of required
front yard

Sky Exposure Plane

SKY EXPOSURE PLANE
R1, R2, R3, R4, R5 Districts

9/30/09

24-522

Front setbacks in districts where front yards are not required

R6 R7 R8 R9 R10

- (a) In the districts indicated, where #front yards# are not required, if the front wall or other portion of a #building or other structure# is located at the #street line# or within the #initial setback distance# set forth in the following table, the height of such front wall or other portion of a #building or other structure# shall not exceed the maximum height above #curb level# set forth in the table. Above such specified maximum height and beyond the #initial setback distance#, the #building or other structure# shall not penetrate the #sky exposure plane# set forth in the table:

MAXIMUM HEIGHT OF FRONT WALL
AND REQUIRED FRONT SETBACKS

#Initial Setback Distance# (in feet)		Maximum Height of a Front Wall or other portion of a Building# within the #Initial Setback Distance#	Height above #Street Line# (in feet)	#Sky Exposure Plane#			
				Slope over #Zoning Lot# (expressed as a ratio of vertical distance to horizontal distance)			
On #Narrow Street#	On #Wide Street#			On #Narrow Street#	On #Wide Street#	On #Narrow Street#	On #Wide Street#
				Vertical Distance	Hori-zontal Distance	Vertical Distance	Hori-zontal Distance

R6 or R7 Districts

20	15	60 feet or six #stories#, whichever is less	60	2.7	to 1	5.6	to 1
----	----	---	----	-----	------	-----	------

R8, R9 or R10 Districts

20	15	85 feet or nine #stories#, whichever is less	85	2.7	to 1	5.6	to 1
----	----	--	----	-----	------	-----	------

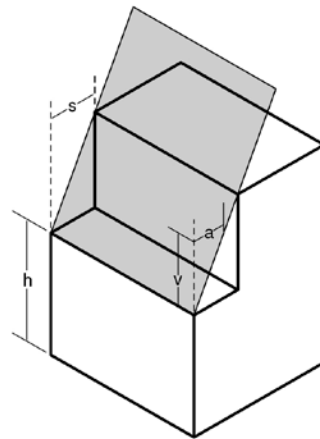

a - Horizontal distance s - Initial setback distance
 h - Height of sky exposure plane above front yard line level v - Vertical distance
 Sky Exposure Plane

SKY EXPOSURE PLANE
R6, R7, R8, R9, R10 Districts

However, where the #residential# portion of any #building# is #developed# or #enlarged# pursuant to the Quality Housing Program, the provisions of this Section, Section 24-53 (Alternate Front Setbacks) and Section 24-54 (Tower Regulations) shall not apply. In lieu thereof, the provisions of Section 23-60 (HEIGHT AND SETBACK REGULATIONS) shall apply.

R6A R6B R7A R7B R7D R7X R8A R8B R8X R9A R9D R9X R10A R10X

- (b) In the districts indicated, for any #development# or #enlargement#, the provisions of this Section, Section 24-53 (Alternate Front Setbacks) and Section 24-54 (Tower Regulations) shall not apply. In lieu thereof, the provisions of Section 23-60 (HEIGHT AND SETBACK REGULATIONS) shall apply.

6/29/06

24-523

Special height and setback regulations

- (a) Community District 7, Manhattan

Within the boundaries of Community District 7 in the Borough of Manhattan, all #developments# or #enlargements# located in R10 Districts, except R10A or R10X Districts, shall comply with the requirements of Section 23-634 (Special height and setback regulations in R10 Districts within Community District 7, Borough of Manhattan).

- (b) R5D Districts

In R5D Districts, all #developments# or #enlargements# shall comply with the height and setback requirements set forth in Section 23-60 (HEIGHT AND SETBACK REGULATIONS).

10/17/07

24-53

Alternate Front Setbacks

R6 R7 R8 R9 R10

In the districts indicated, if an open area is provided along the full length of the #front lot line# with the minimum depth set

forth in the following table, the provisions of Section 24-52 (Maximum Height of Walls and Required Setbacks) shall not apply.

The minimum depth of such an open area shall be measured perpendicular to the #front lot line#. However, in such instances, except as otherwise provided in Sections 24-51 (Permitted Obstructions) or 24-54 (Tower Regulations), no #building or other structure# shall penetrate the alternate #sky exposure plane# set forth in the table, and the #sky exposure plane# shall be measured from a point above the #street line#.

If the open area provided under the terms of this Section is a #public plaza#, such open area may be counted for the bonus provided for a #public plaza# in the districts indicated in Section 24-14 (Floor Area Bonus for a Public Plaza).

In R9 or R10 Districts, the provisions of this Section shall be inapplicable to any #development# or #enlargement# with more than 25 percent of its total #floor area# in #residential use#.

ALTERNATE REQUIRED FRONT SETBACKS

Depth of Optional Front Open Area (in feet)		Height above #Street Line# (in feet)	Alternate #Sky Exposure Plane#			
			Slope over #Zoning Lot# (expressed as a ratio of vertical distance to horizontal distance)			
On #Narrow Street#	On #Wide Street#	#Street Line# (in feet)	On #Narrow Street#		On #Wide Street#	
			Vertical Distance	Hori-zontal Distance	Vertical Distance	Hori-zontal Distance
R6 or R7 Districts						
15	10	60	3.7 to 1		7.6 to 1	
R8 R9 R10 Districts						
15	10	85	3.7 to 1		7.6 to 1	

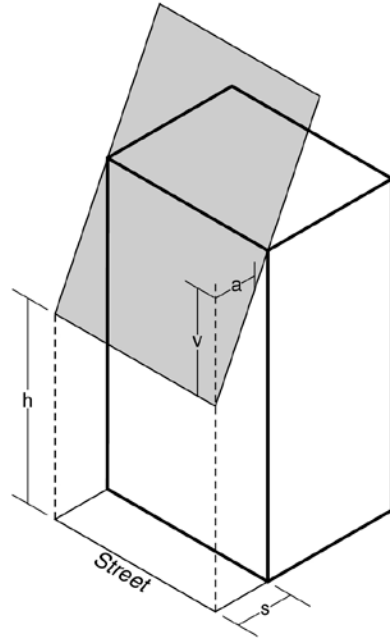

a - Horizontal distance
 h - Height of sky exposure plane above street line
 s - Depth of the optional front open area
 v - Vertical distance
 Sky Exposure Plane

ALTERNATE SKY EXPOSURE PLANE
 R6 R7 R8 R9 R10 Districts

6/12/96

**24-54
 Tower Regulations**

R7-2 R8 R9 R10

In the districts indicated, except as set forth herein, any #building# or #buildings# or portions thereof which in the aggregate occupy not more than 40 percent of the #lot area# of a #zoning lot# or, for #zoning lots# of less than 20,000 square feet, the percentage set forth in Section 24-541 (Towers on small lots), may penetrate an established #sky exposure plane#. (Such #building# or portion thereof is hereinafter referred to as a tower.)

At all levels, such tower shall be located not less than 15 feet from the #street line# of a #narrow street#, and not less than 10

feet from the #street line# of a #wide street#.

Unenclosed balconies, subject to the provisions of Section 24-165 (Balconies in R3 through R10 Districts), are permitted to project into, or over, open areas not occupied by towers.

The provisions of this Section shall not apply to any #building# located wholly or partly in a #Residence District# that is within 100 feet of a #public park# with an area of one acre or more, or a #street line# opposite such a #public park#.

However, in R9 or R10 Districts, the provisions of Section 23-652 (Tower-on-a-base) shall apply to any #development# or #enlargement# that:

- (a) is located on a #wide street# and either within 125 feet from such #wide street# frontage along the short dimension of the #block#, or within 100 feet from such #wide street# frontage along the long dimension of the #block#; and
- (b) contains less than 75 percent of its total #floor area# in #community facility use#.

12/15/61

24-541

Towers on small lots

R7-2 R8 R9 R10

In the districts indicated, a tower may occupy the percent of the #lot area# of a #zoning lot# set forth in the following table:

LOT COVERAGE OF TOWERS
ON SMALL ZONING LOTS

Area of #Zoning Lot# (in square feet)	Maximum Percent of #Lot Coverage#
10,500 or less	50
10,501 to 11,500	49
11,501 to 12,500	48
12,501 to 13,500	47
13,501 to 14,500	46

14,501 to 15,500	45
15,501 to 16,500	44
16,501 to 17,500	43
17,501 to 18,500	42
18,501 to 19,999	41

7/26/01

24-55

Required Side and Rear Setbacks

R1 R2 R3 R4 R5 R6 R7 R8 R9 R10

In all districts, as indicated, side and rear setbacks shall be provided as specified in this Section. Unenclosed balconies, subject to the provisions of Section 24-165 (Balconies), are permitted to project into or over any open areas required by the provisions of this Section.

6/29/06

24-551

Required side setbacks for tall buildings in low bulk districts

R1 R2 R3 R4 R5

In the districts indicated, except R5D Districts, no portion of any #building# that is more than 35 feet or more than three #stories# above the level of a #side yard#, whichever is lower, shall be nearer to a #side lot line# bounding such #yard# than a distance equal to one-half the height above yard level of such portion of the #building#.

The following are permitted to project into any open area required under the provisions of this Section:

- (a) parapet walls, not more than four feet high; and
- (b) chimneys or flues, with a total width not exceeding 10 percent of the width of the building's walls facing such open area.

9/30/09

24-552

Required rear setbacks for tall buildings

R1 R2 R3 R4 R5 R6 R7 R8 R9 R10

- (a) In all districts, as indicated, except as provided in paragraph (b) of this Section, no portion of a #building# more than 125 feet above yard level shall be nearer to a #rear yard line# than 20 feet. However, this provision shall not apply to any portion of a #building# that qualifies as a tower under the provisions of Section 24-54 (Tower Regulations).

In the case of a #through lot# on which a #rear yard equivalent# is provided as set forth in paragraph (a) of Section 24-382 (Required rear yard equivalents), the requirements of this Section shall apply as if such #rear yard equivalent# were two adjoining #rear yards#. If a #rear yard equivalent# is provided as set forth in paragraphs (b) or (c) of Section 24-382, the requirements of this Section shall not apply.

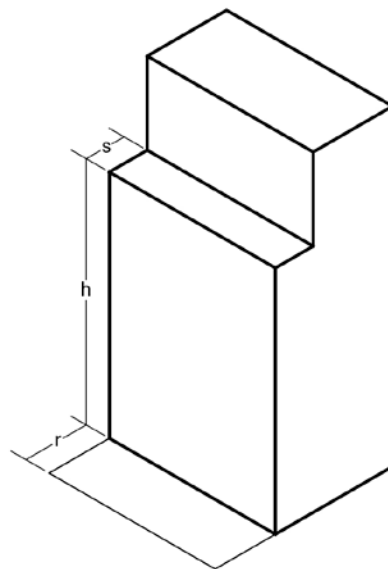

h - Height of wall above rear yard
r - Depth of required rear yard
s - Depth of required rear yard setback

REAR SETBACK FOR TALL BUILDINGS

R6A R6B R7A R7B R7D R7X R8A R8B R8X R9A R9D R9X R10A R10X

- (b) In the districts indicated, for any #development# or #enlargement#, and for #buildings# in which the #residential# portion is #developed# or #enlarged# pursuant to the Quality Housing Program in other R6 through R10 Districts, no portion of a #building# that exceeds the maximum base height specified in the table in Section 23-633 shall be nearer to a #rear yard line# than 10 feet.

In the case of a #through lot# on which a #rear yard equivalent# is provided as set forth in paragraph (a) of Section 24-382, the requirements of this Section shall apply as if such #rear yard equivalent# were two adjoining #rear yards#. If a #rear yard equivalent# is provided as set forth in paragraph (b) of Section 24-382, the requirements of this Section shall not apply.

Regulations Applying in Special Situations

12/15/61

24-56

Special Provisions for Zoning Lots Directly Adjoining Public Parks

R1 R2 R3 R4 R5 R6 R7 R8 R9 R10

In all districts, as indicated, a #public park# with an area of between one and fifteen acres shall be considered a #wide street# for the purpose of applying the regulations set forth in Section 24-52 (Maximum Height of Front Wall and Required Front Setbacks) to any #building or other structure# on a #zoning lot# adjoining such #public park#. However, the provisions of this Section shall not apply to a #public park# more than 75 percent of which is paved.

7/23/08

24-57

Modifications of Height and Setback Regulations

R1 R2 R3 R4 R5 R6 R7 R8 R9 R10

In all districts, as indicated, for certain #community facility

uses# in specified situations, the Board of Standards and Appeals may modify the regulations set forth in Sections 24-51 to 24-55, inclusive, relating to Height and Setback Regulations, in accordance with the provisions of Section 73-64 (Modifications for Community Facility Uses).

In Community District 6 in the Borough of Brooklyn, the following #streets# shall be considered #narrow streets# for the purposes of applying height and setback regulations: Second, Carroll and President Streets, between Smith and Hoyt Streets; First Place, Second Place, Third Place and Fourth Place.

8/14/87

24-58

Special Provisions for Zoning Lots Divided by District Boundaries

R1 R2 R3 R4 R5 R6 R7 R8 R9 R10

In all districts, as indicated, whenever a #zoning lot# is divided by a boundary between districts, or is subject to other regulations resulting in different height and setback regulations, or whenever a #zoning lot# is divided by a boundary between a district to which the provisions of Section 24-54 (Tower Regulations) apply and a district to which such provisions do not apply, the provisions set forth in Article VII, Chapter 7, shall apply.

6/29/94

24-59

Special Height Limitations

6/29/94

24-591

Limited Height Districts

R1 R2 R3 R4 R5 R6 R7 R8 R9 R10

In all districts, as indicated, wherever such districts are located within a #Limited Height District#, the maximum height of a #building or other structure#, or portion thereof, shall be as shown in the following table:

#Limited Height District#	Maximum Height above #Curb Level# or #Base Plane#, as Applicable
---------------------------	--

LH-1	50 feet
LH-1A	60 feet
LH-2	70 feet
LH-3	100 feet

10/29/07

24-592

Height limitations for narrow buildings or enlargements

R7-2 R7D R7X R8 R9 R10

In the districts indicated, if the width of the #street wall# of a new #building#, or the #enlarged# portion of an existing #building#, is 45 feet or less, the provisions of Section 23-692 (Height limitations for narrow buildings or enlargements) shall apply to such new or #enlarged building#.

12/15/61

24-60

COURT REGULATIONS AND MINIMUM DISTANCE BETWEEN WINDOWS AND WALLS OR LOT LINES

3/8/62

24-61

General Provisions and Applicability

R1 R2 R3 R4 R5 R6 R7 R8 R9 R10

In all districts, as indicated, the provisions set forth in Sections 24-62 to 24-66, inclusive, relating to Court Regulations and Minimum Distance between Windows and Walls or Lot Lines, shall apply only to #community facility buildings# or portions of #buildings# used for #community facility use# containing living

accommodations with required windows. For the purposes of these Sections, a required window shall be deemed to be a window or part of a window that:

- (a) opens into any room used for living or sleeping purposes, other than a room in a hospital used for the care or treatment of patients; and
- (b) is required to provide adequate light or ventilation to such room by any applicable law or statute.

The provisions of Sections 24-62 to 24-66, inclusive, and 24-68 shall apply only to portions of #buildings# at or above the sill level of the lowest required window.

11/7/68

24-62

Minimum Dimensions of Courts

R1 R2 R3 R4 R5 R6 R7 R8 R9 R10

In all districts, as indicated, the minimum distance between different walls of the same #building# shall conform to the regulations set forth in the following Sections:

Section 24-63 (Outer Court Regulations)

Section 24-64 (Inner Court Regulations)

Section 24-65 (Minimum Distance between Required Windows and Walls or Lot Lines).

A corner of a #court# may be cut off between walls of the same #building#, provided that the length of the wall of such cut-off does not exceed seven feet.

The Commissioner of Buildings may approve minor recesses, projections and architectural treatment of the outline of #courts# as long as these variations do not substantially change the depth or width of the #court#.

12/15/61

24-63

Outer Court Regulations

R1 R2 R3 R4 R5 R6 R7 R8 R9 R10

In all districts, as indicated, #outer courts# shall be in compliance with the provisions of this Section.

6/29/94

24-631

Narrow outer courts

R1 R2 R3 R4 R5 R6 R7 R8 R9 R10

In all districts, as indicated, if an #outer court# is less than 20 feet wide, the width of such #outer court# shall be at least one and one-third the depth of such #outer court#.

12/15/61

24-632

Wide outer courts

R1 R2 R3 R4 R5 R6 R7 R8 R9 R10

In all districts, as indicated, if an #outer court# is 20 feet or more in width, the width of such #outer court# must be at least equal to the depth of such #outer court#, except that such width need not exceed 40 feet.

12/15/61

24-633

Outer court recesses

R1 R2 R3 R4 R5 R6 R7 R8 R9 R10

In all districts, as indicated, the width of an #outer court recess# shall be at least twice the depth of the recess, except that such width need not exceed 40 feet.

12/15/61

24-64

Inner Court Regulations

R1 R2 R3 R4 R5 R6 R7 R8 R9 R10

In all districts, as indicated, #inner courts# shall be in compliance with the provisions of this Section.

12/15/61

24-641

Minimum dimensions of inner courts

R1 R2 R3 R4 R5 R6 R7 R8 R9 R10

In all districts, as indicated, the area of an #inner court# shall not be less than 600 square feet, and the minimum dimension of such #inner court# shall not be less than 20 feet. For the purposes of this Section, that portion of an open area not part of an #inner court# and over which, when viewed from directly above, lines perpendicular to a #lot line# may be drawn into such #inner court#, shall be considered part of such #inner court#.

12/15/61

24-642

Inner court recesses

R1 R2 R3 R4 R5 R6 R7 R8 R9 R10

In all districts, as indicated, the width of an #inner court recess#:

- (a) if 20 feet or less, shall be at least twice the depth of the recess; or
- (b) if more than 20 feet but less than 40 feet, shall be at least equal to the depth of the recess; and
- (c) need not be greater than 40 feet, whatever the depth of the recess.

12/15/61

24-65

Minimum Distance between Required Windows and Walls or Lot Lines

R1 R2 R3 R4 R5 R6 R7 R8 R9 R10

In all districts, as indicated, the minimum distance between required windows and walls or #lot lines# shall be as set forth in this Section, except that this Section shall not apply to required windows in #buildings# of three #stories# or less.

12/15/61

24-651

General provisions

R1 R2 R3 R4 R5 R6 R7 R8 R9 R10

In all districts, as indicated, except as otherwise provided in Section 24-652 (Minimum distance between required windows and certain walls), the minimum distance between any required windows and:

- (a) any wall;
- (b) a #rear lot line#, or vertical projection thereof; or
- (c) a #side lot line#, or vertical projection thereof;

shall be 20 feet, measured in a horizontal plane at the sill level of, and perpendicular to, such window; provided, however, that a required window may open on any #outer court# meeting the requirements of Section 24-63 (Outer Court Regulations).

12/15/61

24-652

Minimum distance between required windows and certain walls

R1 R2 R3 R4 R5 R6 R7 R8 R9 R10

In all districts, as indicated, the minimum horizontal distance between a required window opening on an #inner court# and any wall opposite such window on the same #zoning lot# or between a required window and any wall of any other #building# opposite such window on the same #zoning lot#, shall not be less than 20 feet, nor shall any such wall be nearer to such window than a

distance equal to one-third the total height of such wall above the sill level of such window. Such minimum distance need not exceed 40 feet.

Such minimum distance shall be measured in a horizontal plane at the sill level of, and perpendicular to, the required window for the full width of the rough window opening between such window and a projection of such wall onto such horizontal plane.

For the purposes of this Section, at any level at which two portions of a single #building# are not connected one to the other, such portions shall be deemed to be two separate #buildings# and shall be subject to the provisions of this Section.

12/15/61

24-66

Modifications of Court Regulations or Distance Requirements

R1 R2 R3 R4 R5 R6 R7 R8 R9 R10

In all districts, as indicated, for certain #community facility uses# in specified situations, the Board of Standards and Appeals may modify the regulations set forth in Sections 24-61 to 24-65, inclusive, relating to Court Regulations and Minimum Distance between Windows and Walls or Lot Lines, in accordance with the provisions of Section 73-64 (Modifications for Community Facility Uses).

6/29/94

24-67

Special Provisions for Buildings Used Partly for Residential Uses

R1 R2 R3 R4 R5 R6 R7 R8 R9 R10

In all districts, as indicated, whenever a #building# is used partly for #community facility use# and partly for #residential use#, the provisions of this Section and Section 23-70 (MINIMUM DISTANCE REQUIRED BETWEEN TWO OR MORE BUILDINGS ON A SINGLE ZONING LOT) shall apply to any portion of such #building# used for #residential uses#.

12/15/61

**24-671
Courts**

R1 R2 R3 R4 R5 R6 R7 R8 R9 R10

In all districts, as indicated, at any level at which a #building# is used for #residential use#, any #court# upon which a #legally required window# opens shall be subject to the provisions set forth in Sections 23-84 (Outer Court Regulations) or 23-85 (Inner Court Regulations).

12/15/61

**24-672
Walls opposite legally required windows**

R1 R2 R3 R4 R5 R6 R7 R8 R9 R10

In all districts, as indicated, #legally required windows# in portions of #buildings# used for #residential use# shall be subject to the provisions set forth in Section 23-86 (Minimum Distance between Legally Required Windows and Walls or Lot Lines). The provisions of Section 23-863 (Minimum distance between legally required windows and any wall in an inner court) shall also apply to a #legally required window# opposite a wall of any other #building# on the same #zoning lot#.

For the purposes of this Section, at any level at which two portions of a single #building# are not connected one to the other, such portions shall be deemed to be two separate #buildings# and shall be subject to the provisions of Section 23-863.

3/21/68

**24-68
Permitted Obstruction in Courts**

R1 R2 R3 R4 R5 R6 R7 R8 R9 R10

In all districts, as indicated, the following shall not be considered obstructions when located within a #court#:

Arbors or trellises;

Eaves, gutters, downspouts, window sills or similar projections extending into such #court# not more than four inches;

Fences;

Fire escapes in #inner courts#, where such fire escapes are required as a result of alterations in #buildings# existing before December 15, 1961;

Fire escapes in #outer courts#;

Fire escapes in #outer court recesses#, not more than five feet in depth;

Fire escapes in #outer court recesses#, more than five feet in depth, where such fire escapes are required as a result of alterations in #buildings# existing before December 15, 1961;

Flagpoles;

Recreational or yard drying equipment;

Terraces, open, porches or steps.