



HOWARD L.
ZIMMERMAN
ARCHITECTS PC

375 West Broadway

Proposal for Vault and Sidewalk Replacement

Presented to NYC Community Board No. 2

December 15th, 2016

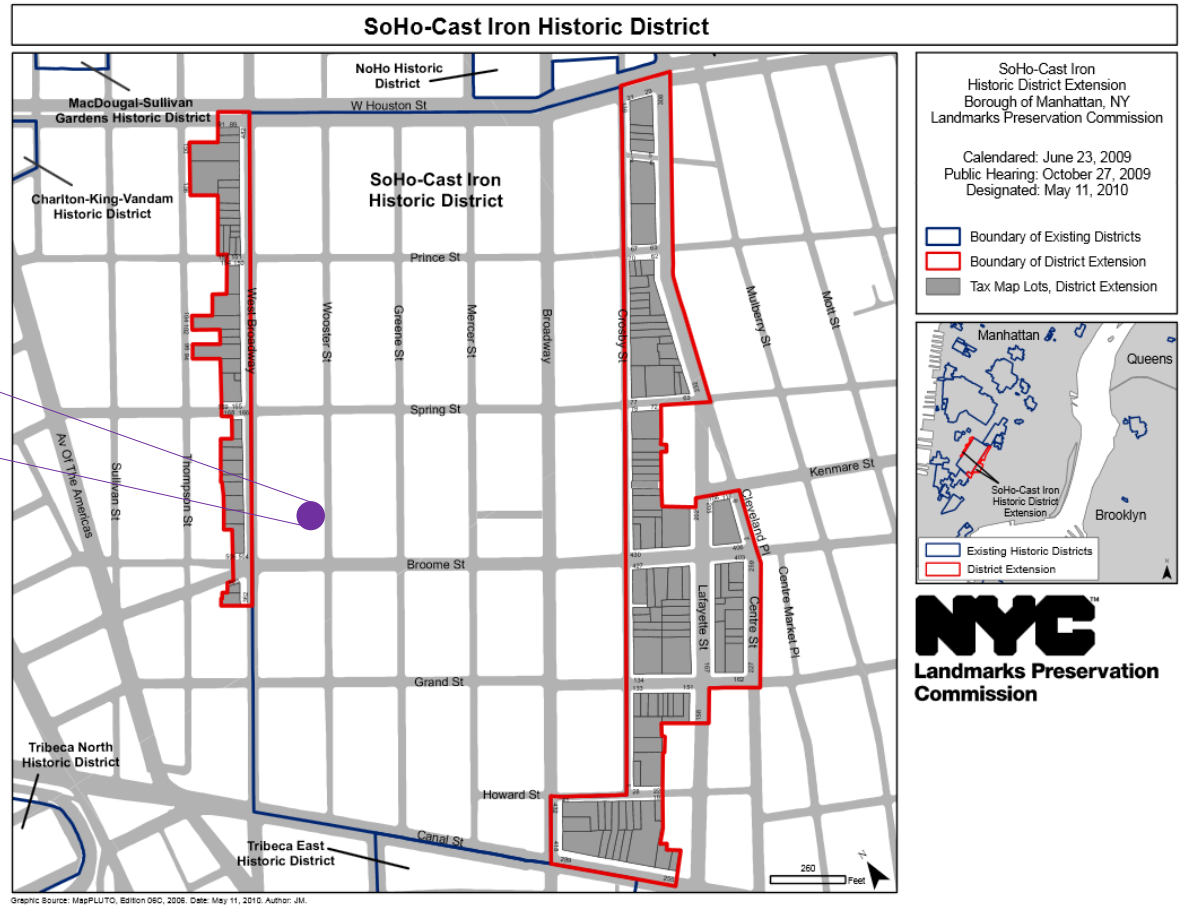
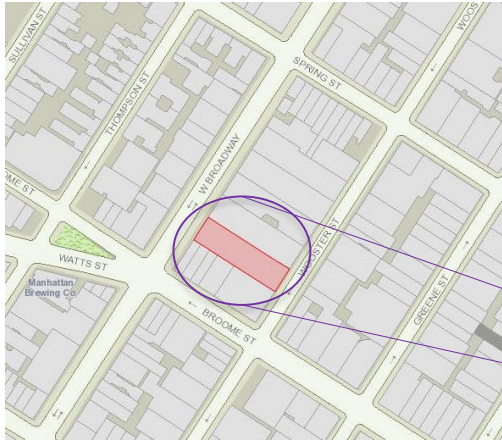

Soho-Cast Iron Historic District

375 West Broadway – Vault and Sidewalk Replacement



Building Information:

- Year built: 1900
- Commercial
- Number of floors: 5
- Historic District: Soho-Cast Iron Historic District
- Not individually Landmarked



375 West Broadway – Vault and Sidewalk Replacement



Proposed Scope of Work:

- Vault and sidewalk replacement
- Sidewalk and diamond plate to be replaced *in-kind* to match existing
- New cast iron vault light risers to match original historic risers
- Removal of hatch replaced with stairs to match adjacent
- New code compliant railing



375 West Broadway – Vault and Sidewalk Replacement



- Building's vault is separated into three (3) separate vaults, numbered from the south.



Wooster Street looking north.

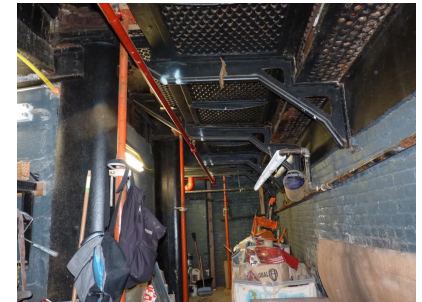

375 West Broadway – Vault and Sidewalk Replacement

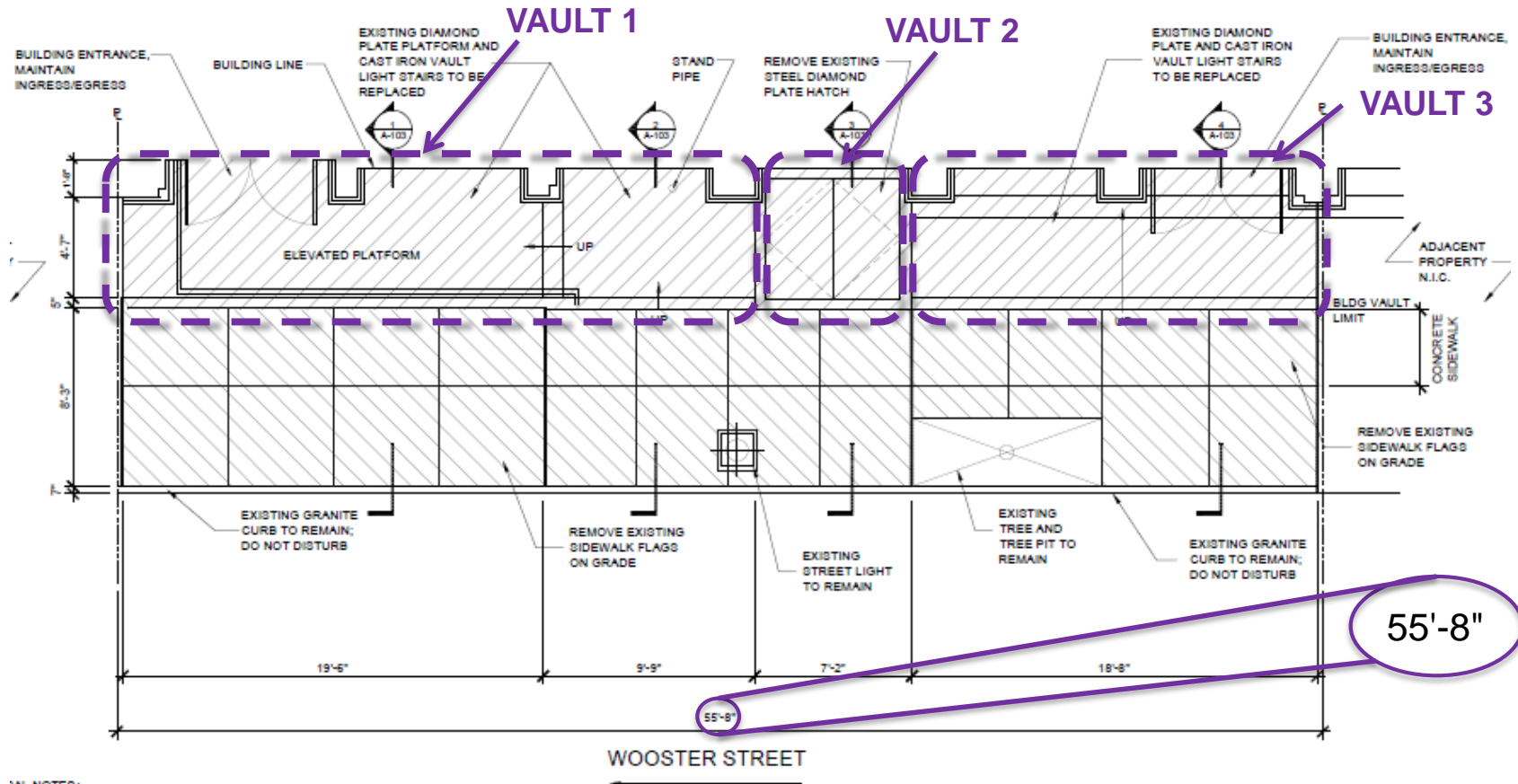

GENERAL NOTES:

375 West Broadway – Vault and Sidewalk Replacement

- Vault #1 (from south)

HLZA



375 West Broadway – Vault and Sidewalk Replacement

- Vault #2 (Hatch)

HLZA



375 West Broadway – Vault and Sidewalk Replacement



- **Vault #3**
 - Extensive electrical equipment recently replaced due to excessive water infiltration



375 West Broadway – Vault and Sidewalk Replacement



- Historic glass vault lights in Vaults #1 and #3

APPROXIMATELY 320 SF

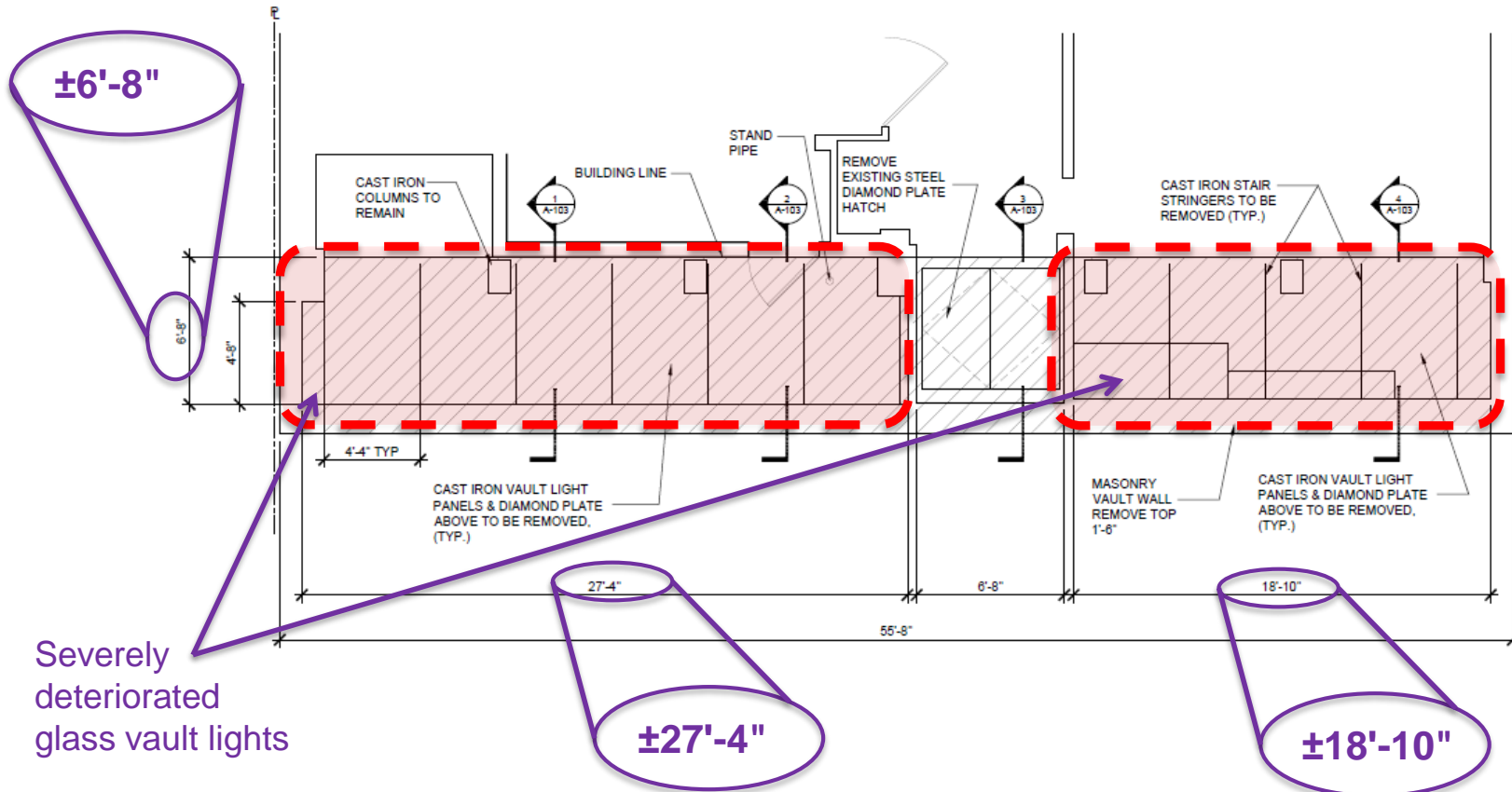

375 West Broadway – Vault and Sidewalk Replacement

- Historic glass vault lights in Vault #1

HLZA

KEY

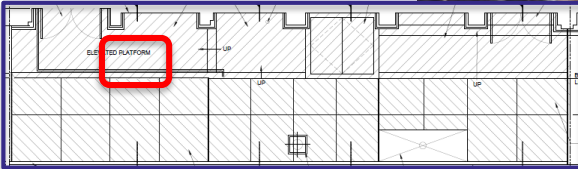

Severely deteriorated cast iron and missing glass vault lights.

Note: Underside of vault lights recently painted for building sale to hide defects



375 West Broadway – Vault and Sidewalk Replacement

- Historic glass vault lights in Vault #1



KEY



Severely deteriorated and missing cast iron framing and vault lights

Fractured cast iron stair tread

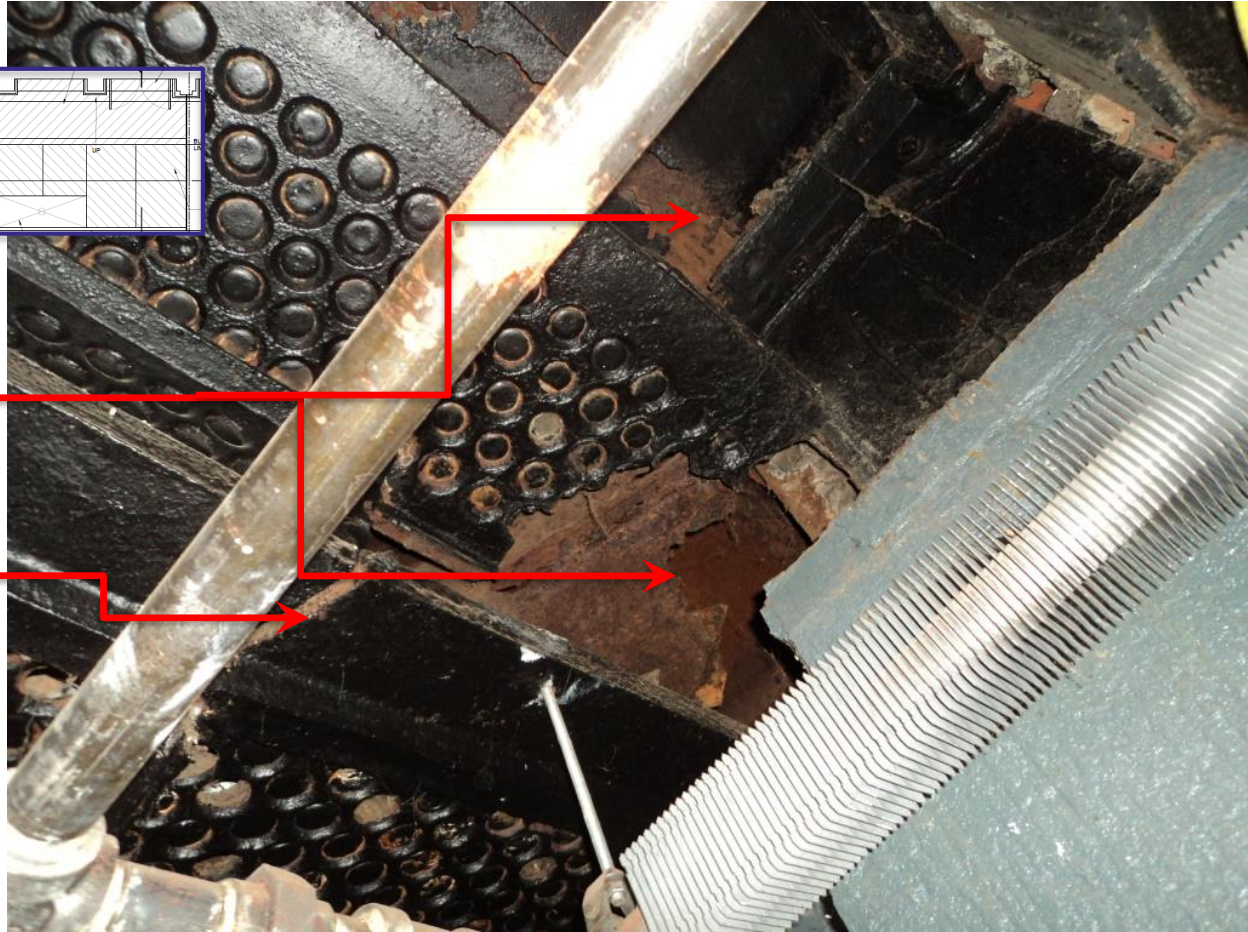

375 West Broadway – Vault and Sidewalk Replacement

- Historic glass vault lights in Vault #1

Missing vault light panel



KEY

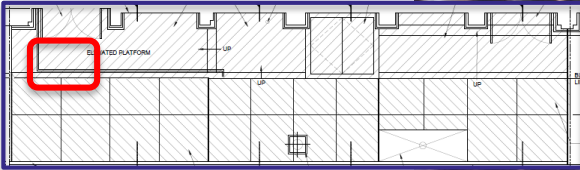

Severely deteriorated and missing cast iron framing and vault lights.

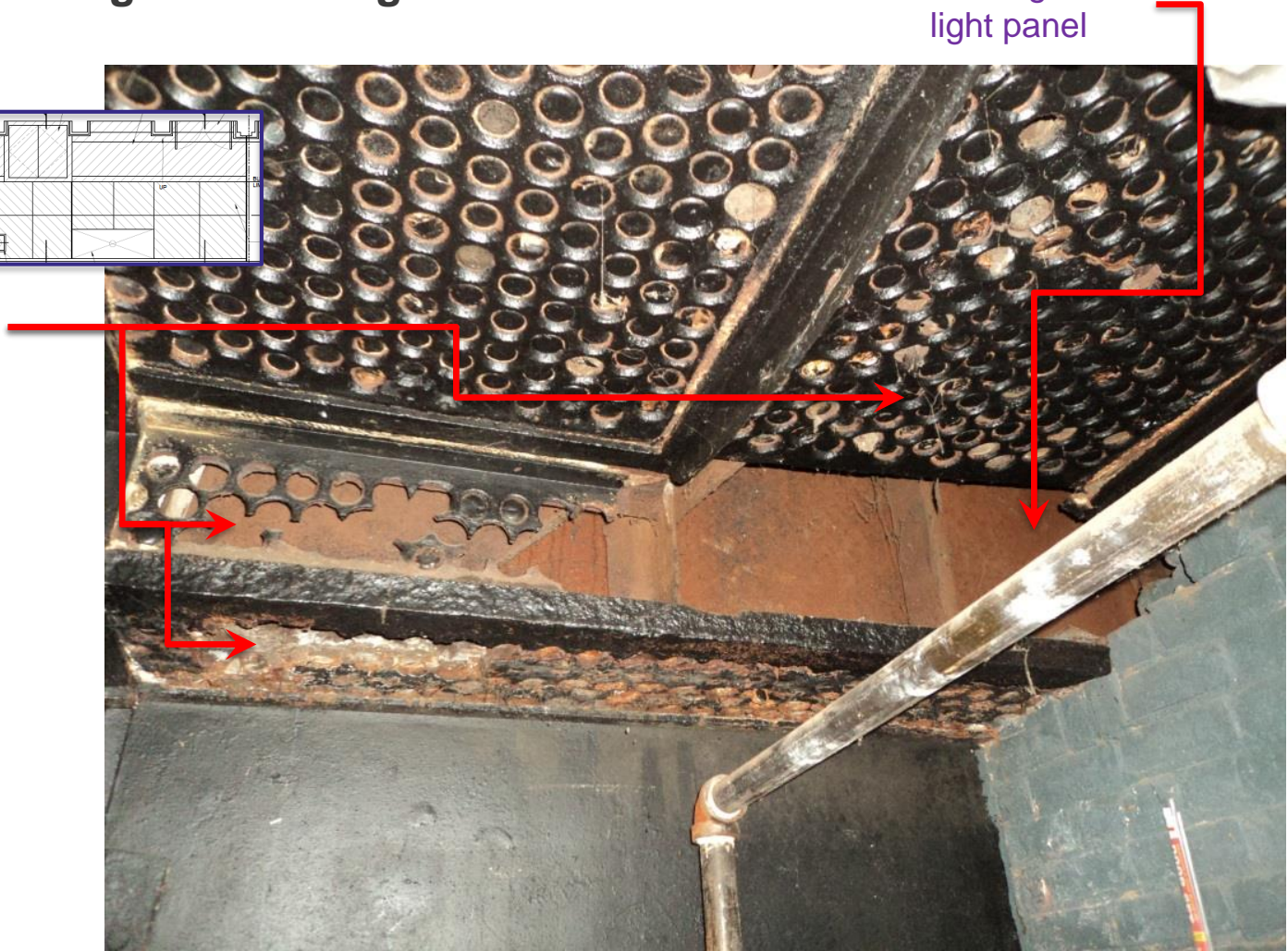

375 West Broadway – Vault and Sidewalk Replacement

- Historic glass vault lights in Vault #1

HLZA

KEY

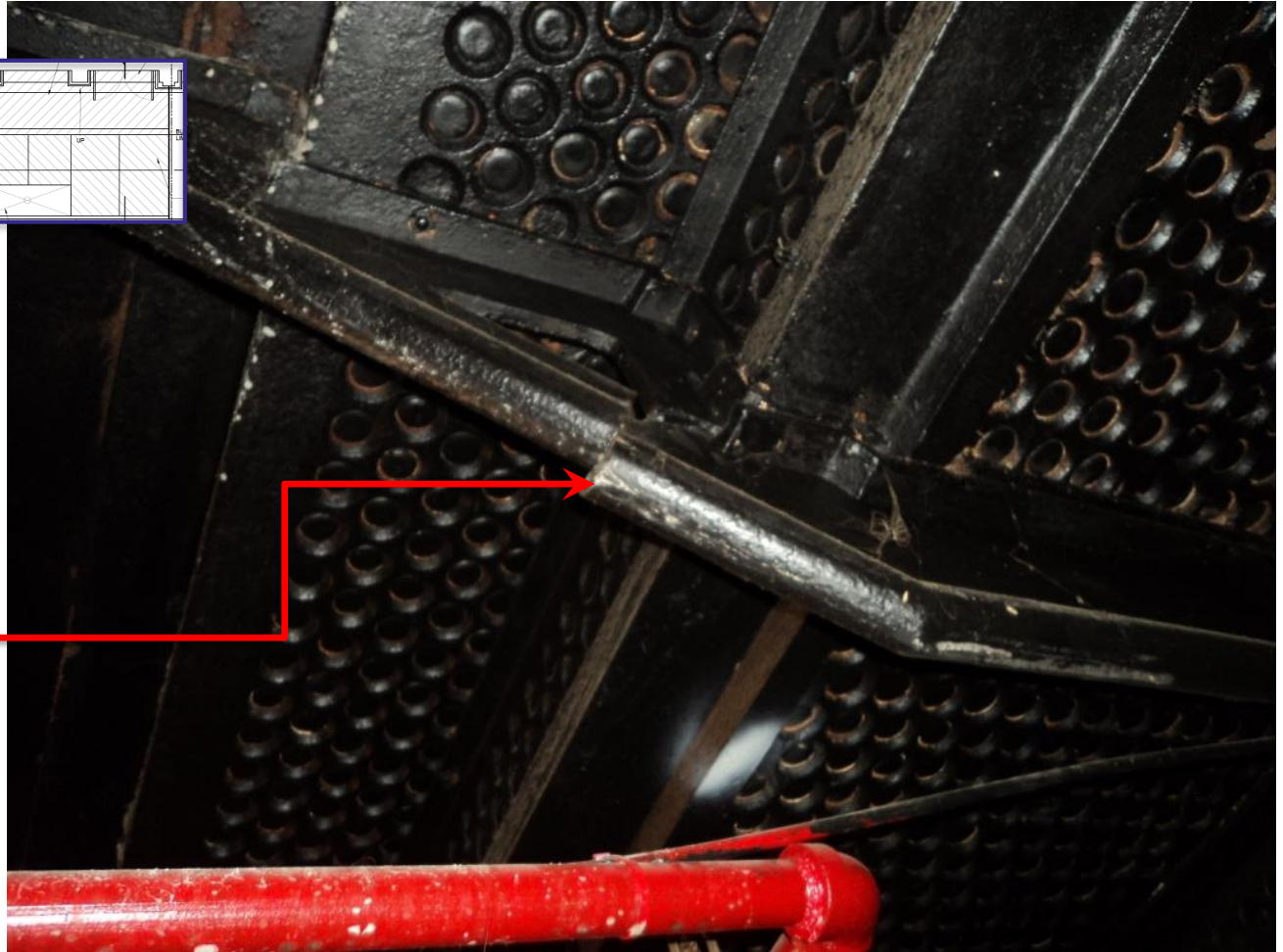
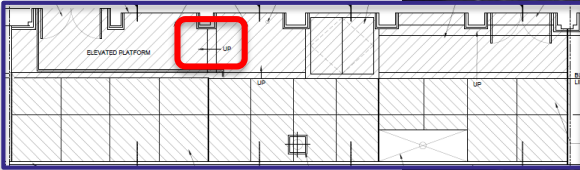

Fractured cast iron stringer.

375 West Broadway – Vault and Sidewalk Replacement

- Historic glass vault lights in Vault #1



KEY

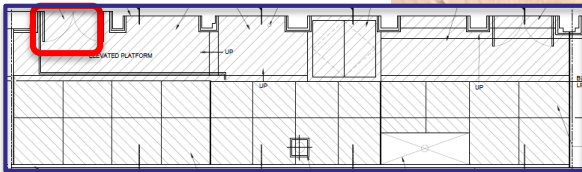

Severely deteriorated and missing vault lights

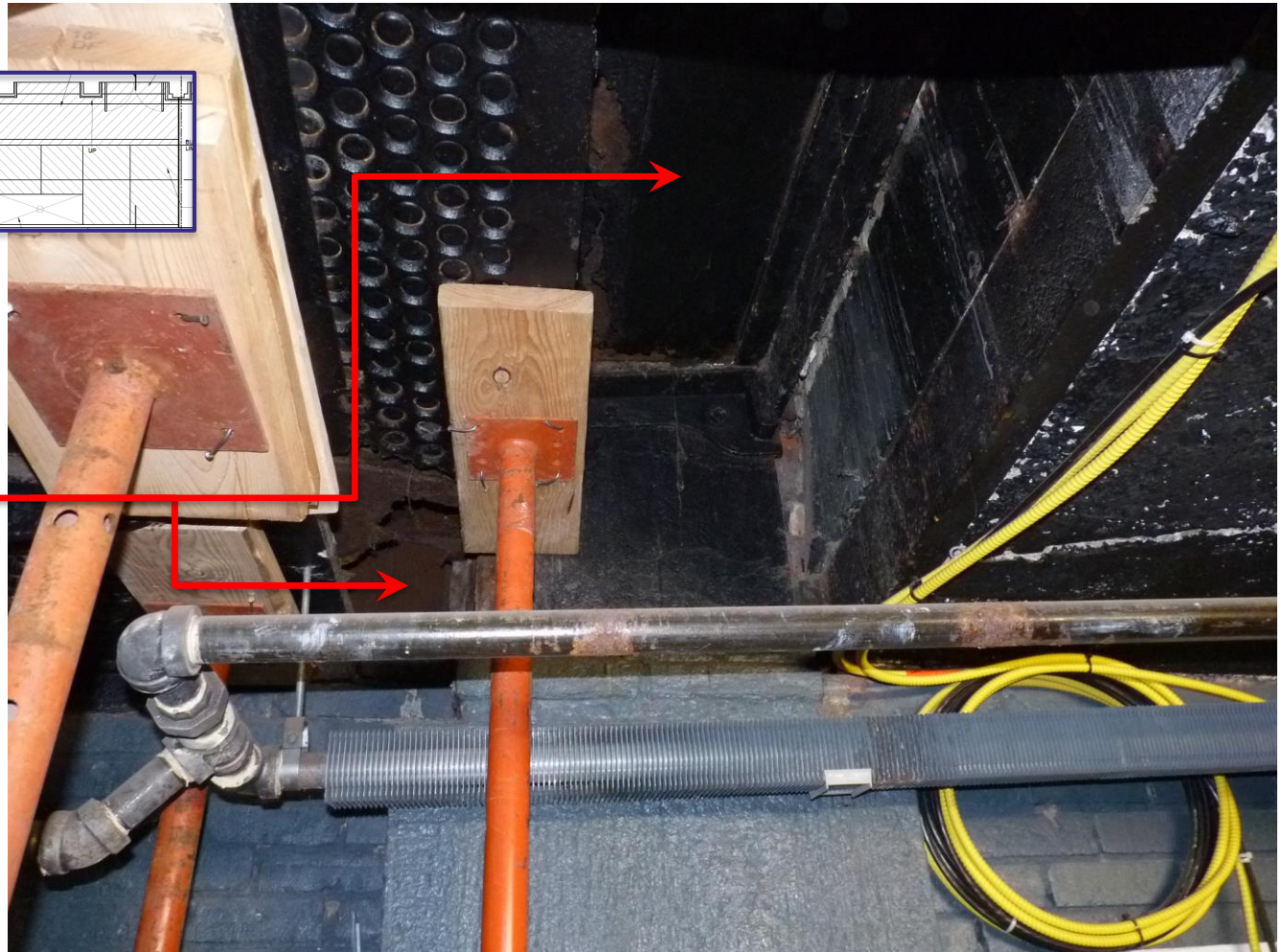

- Historic glass vault lights in Vault #1



KEY

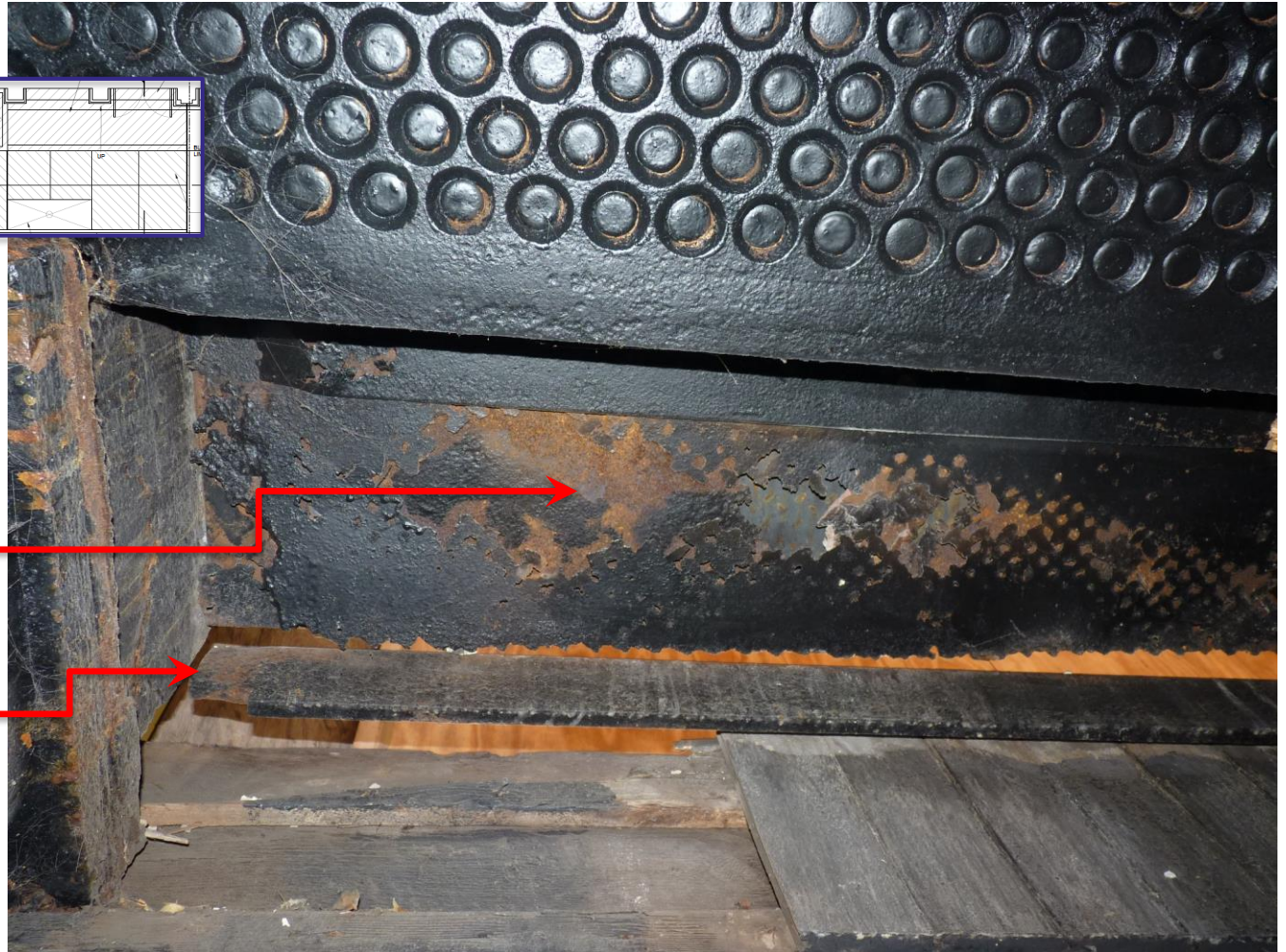
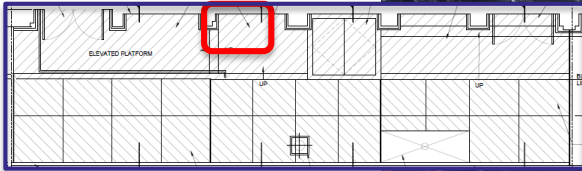

Missing vault light panel

Missing cast iron connection

375 West Broadway – Vault and Sidewalk Replacement

- Historic glass vault lights in Vault #1



KEY

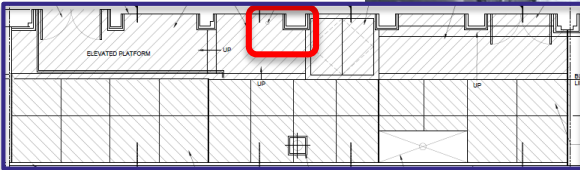

Missing vault light panels

375 West Broadway – Vault and Sidewalk Replacement

- Historic glass vault lights in Vault #1

HLZA

KEY

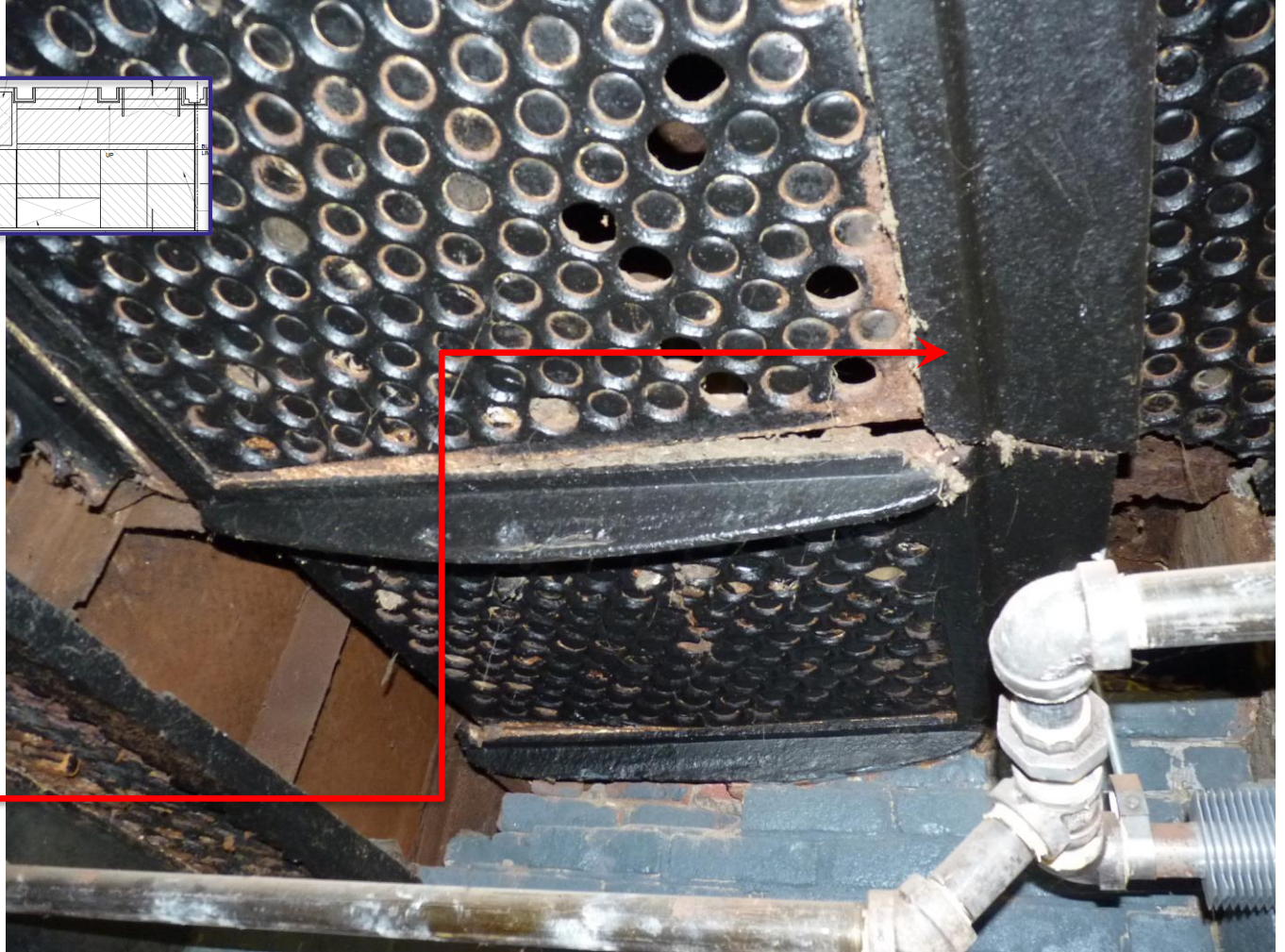
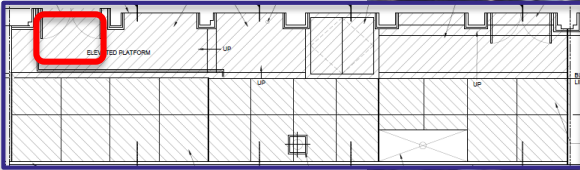

Fractured vault light panel.

375 West Broadway – Vault and Sidewalk Replacement

- Historic glass vault lights in Vault #1

HLZA

KEY

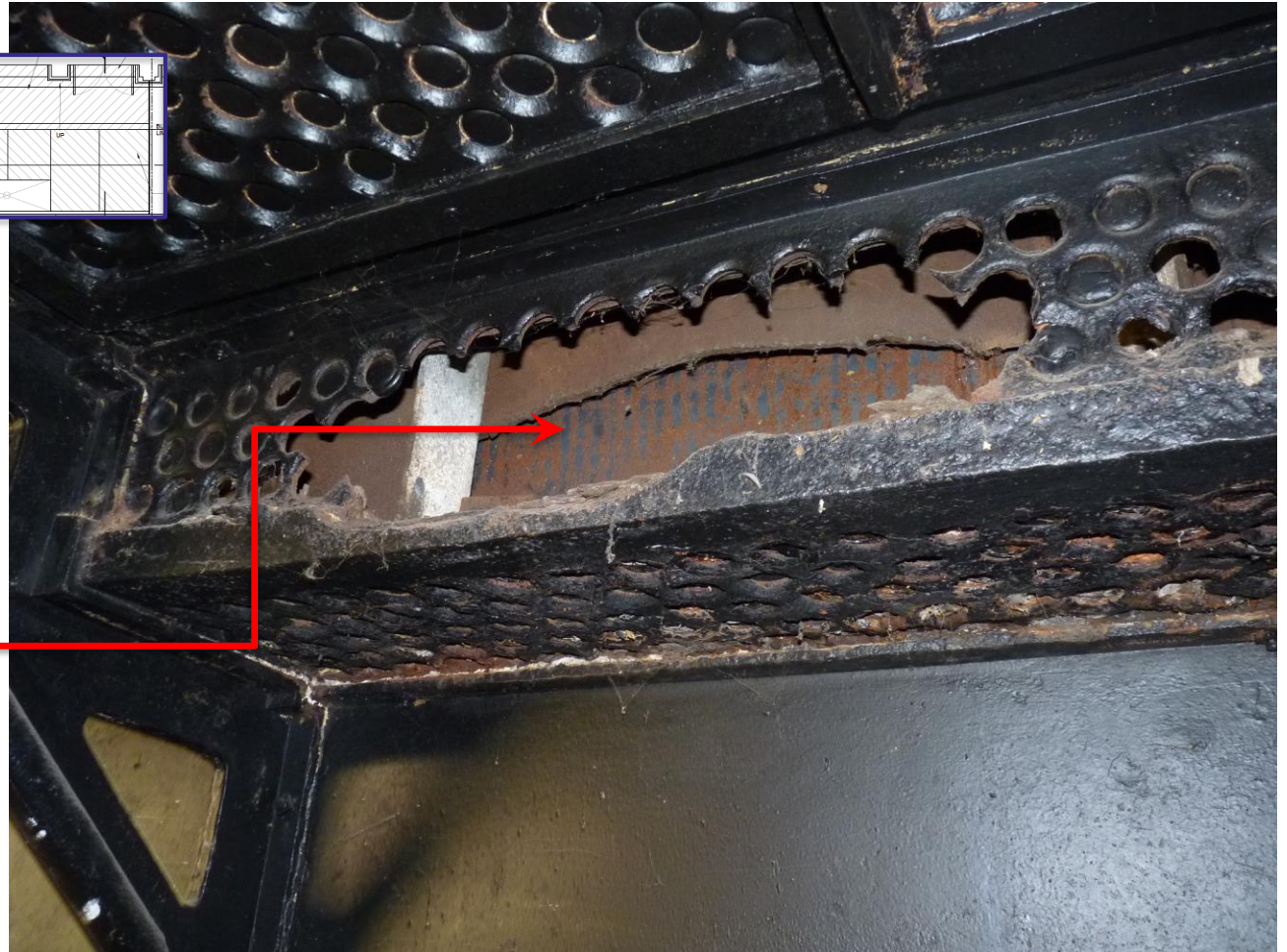
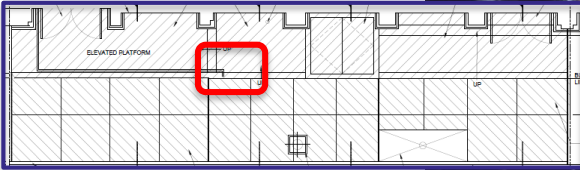

Severely
deteriorated cast
iron vault light riser.

375 West Broadway – Vault and Sidewalk Replacement

- Historic glass vault lights in Vault #3

HLZA

KEY

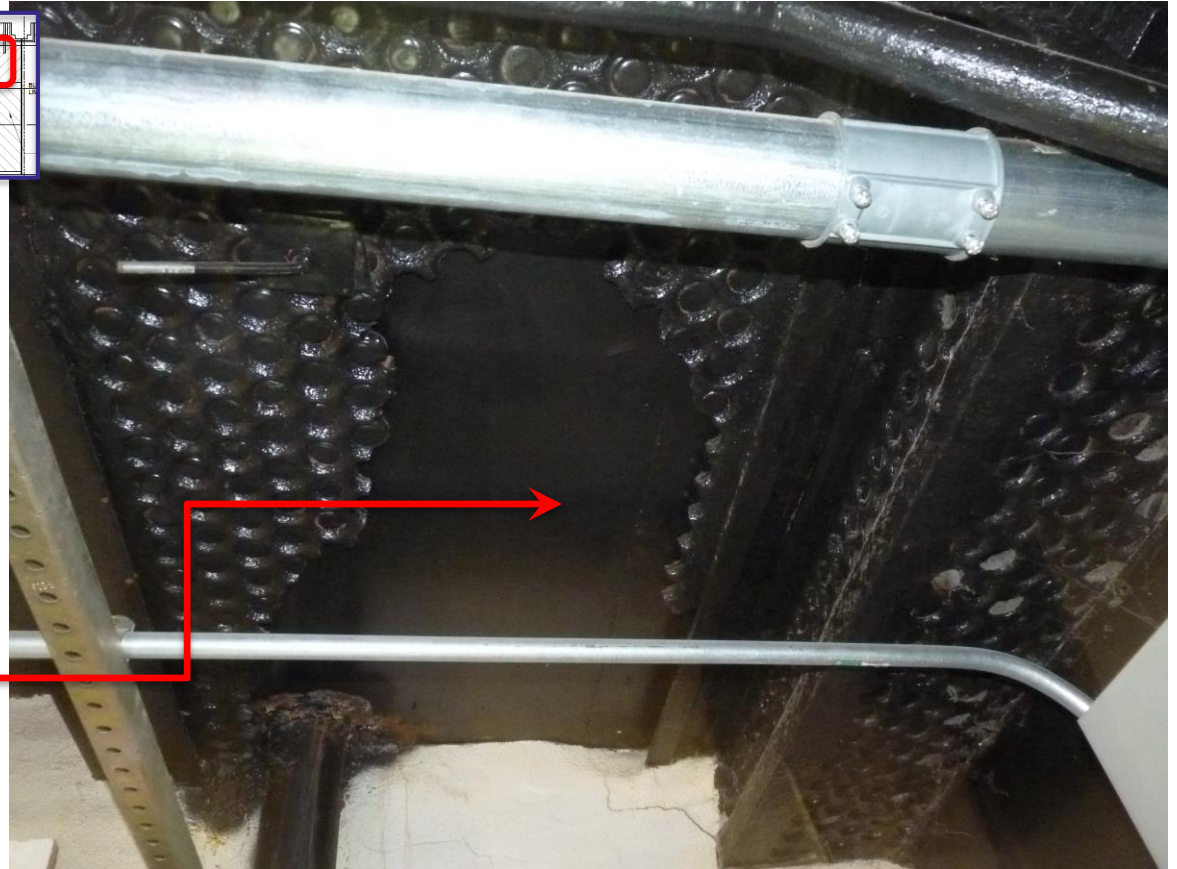
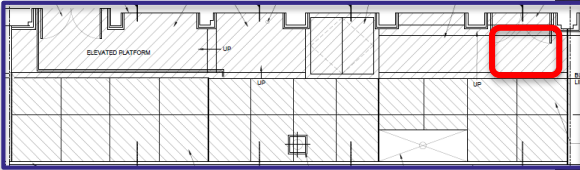

Severely
deteriorated
vault light panel.

375 West Broadway – Vault and Sidewalk Replacement



- Historic glass vault lights in Vault #3

KEY

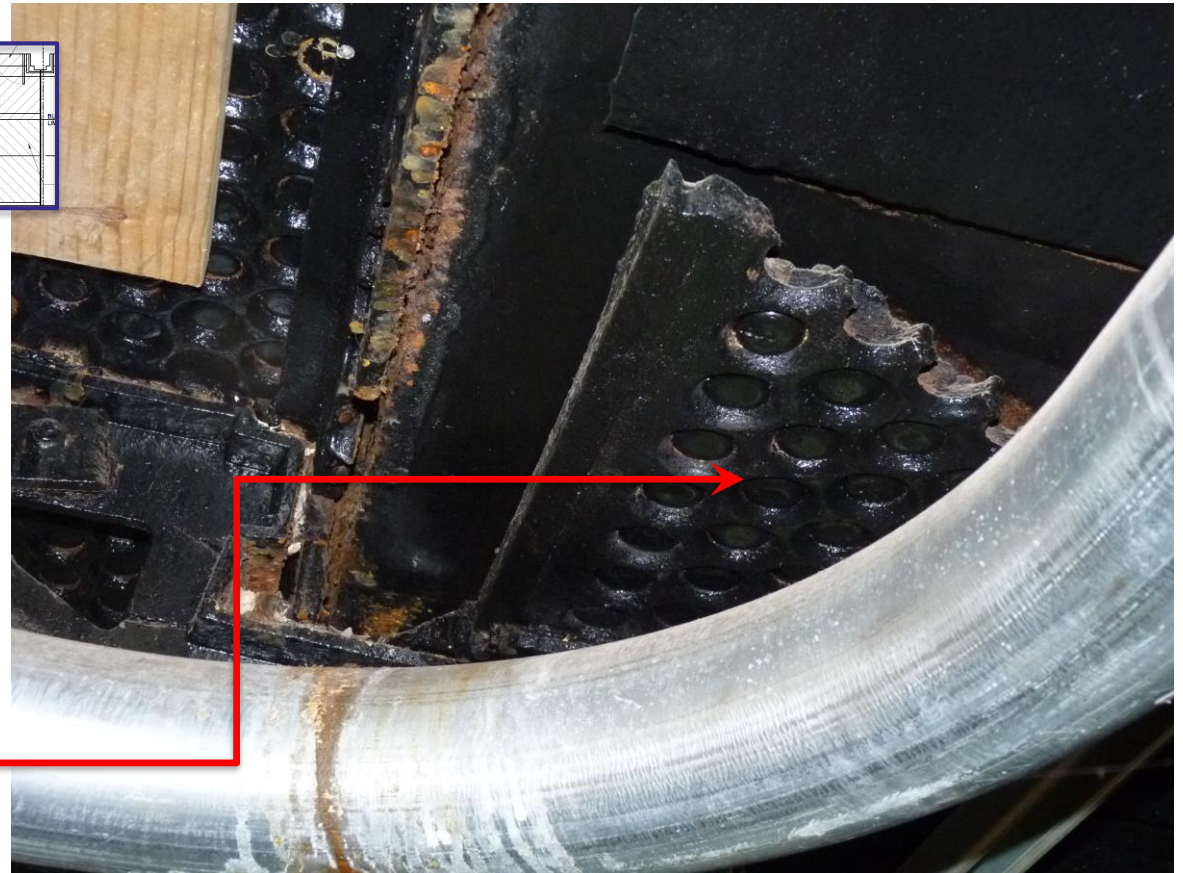
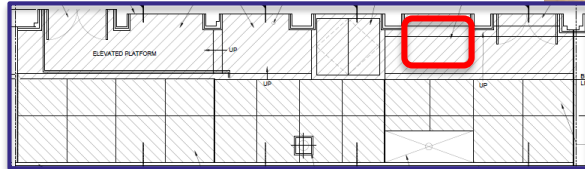

Severely
deteriorated
vault lights.

375 West Broadway – Vault and Sidewalk Replacement



- Historic glass vault lights in Vault #3

KEY

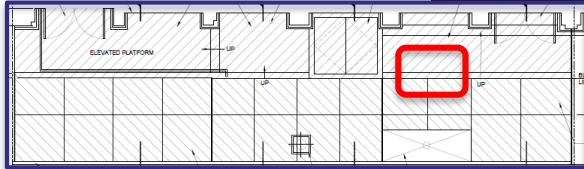

Fractured cast iron framing

375 West Broadway – Vault and Sidewalk Replacement



- Historic glass vault lights in Vault #3

KEY

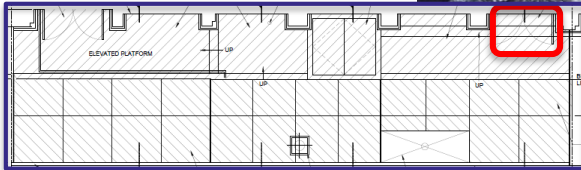

Severely
deteriorated
vault lights.

375 West Broadway – Vault and Sidewalk Replacement



- Historic glass vault lights in Vault #3

KEY

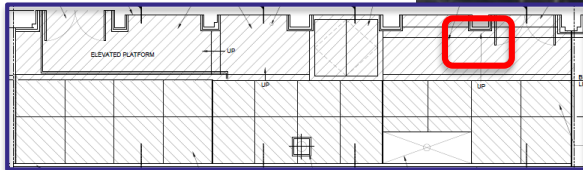

Fractured and
deteriorated cast
iron stringer

375 West Broadway – Vault and Sidewalk Replacement



- Historic glass vault lights in Vault #3

KEY

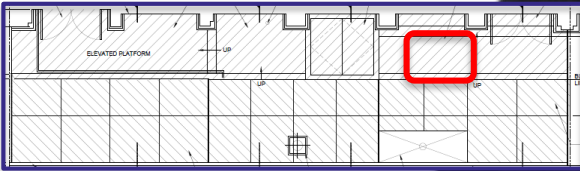

Severely deteriorated and missing cast iron vault lights panels



375 West Broadway – Vault and Sidewalk Replacement

- Existing Wooster Street Storefront

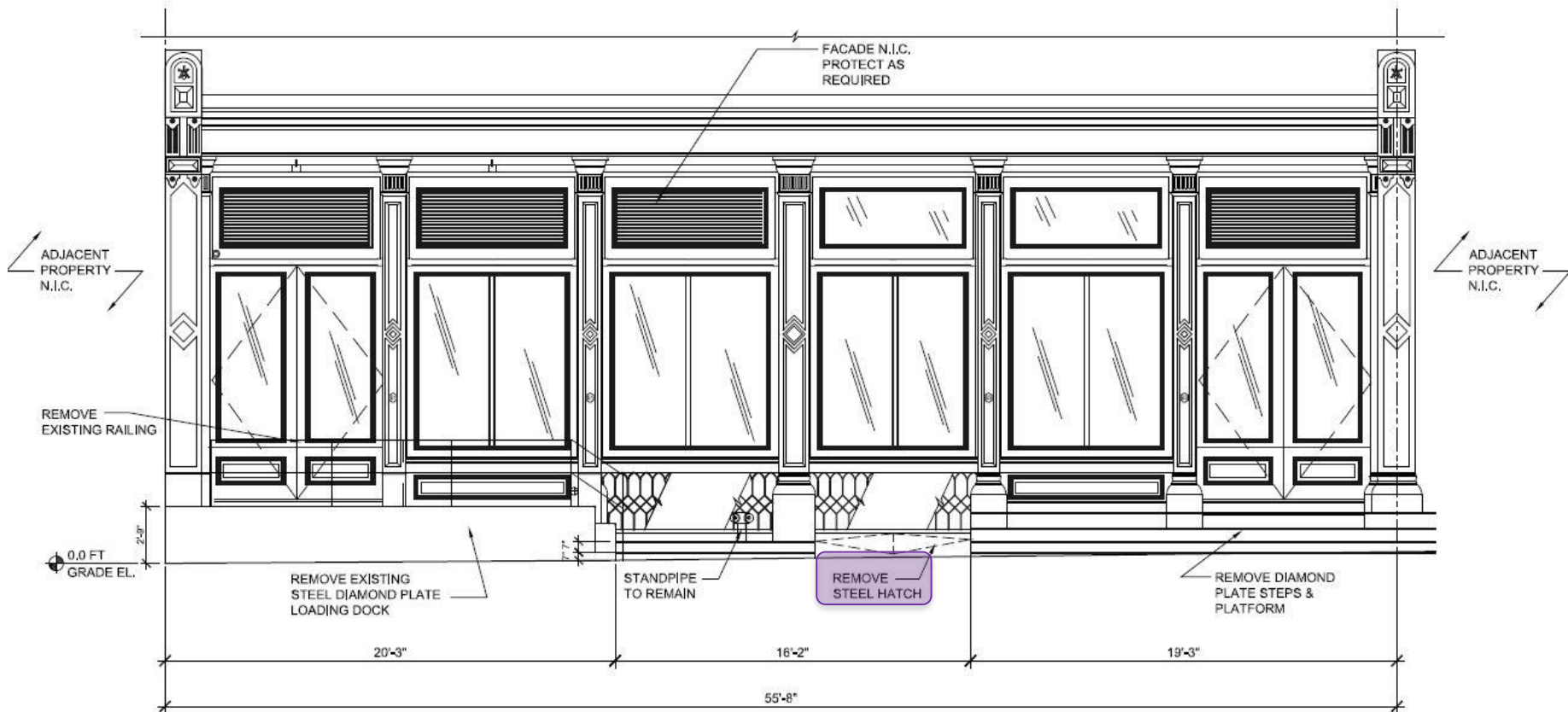

375 West Broadway – Vault and Sidewalk Replacement



- **Proposed Wooster Street Storefront**
 - Glass vault lights on risers

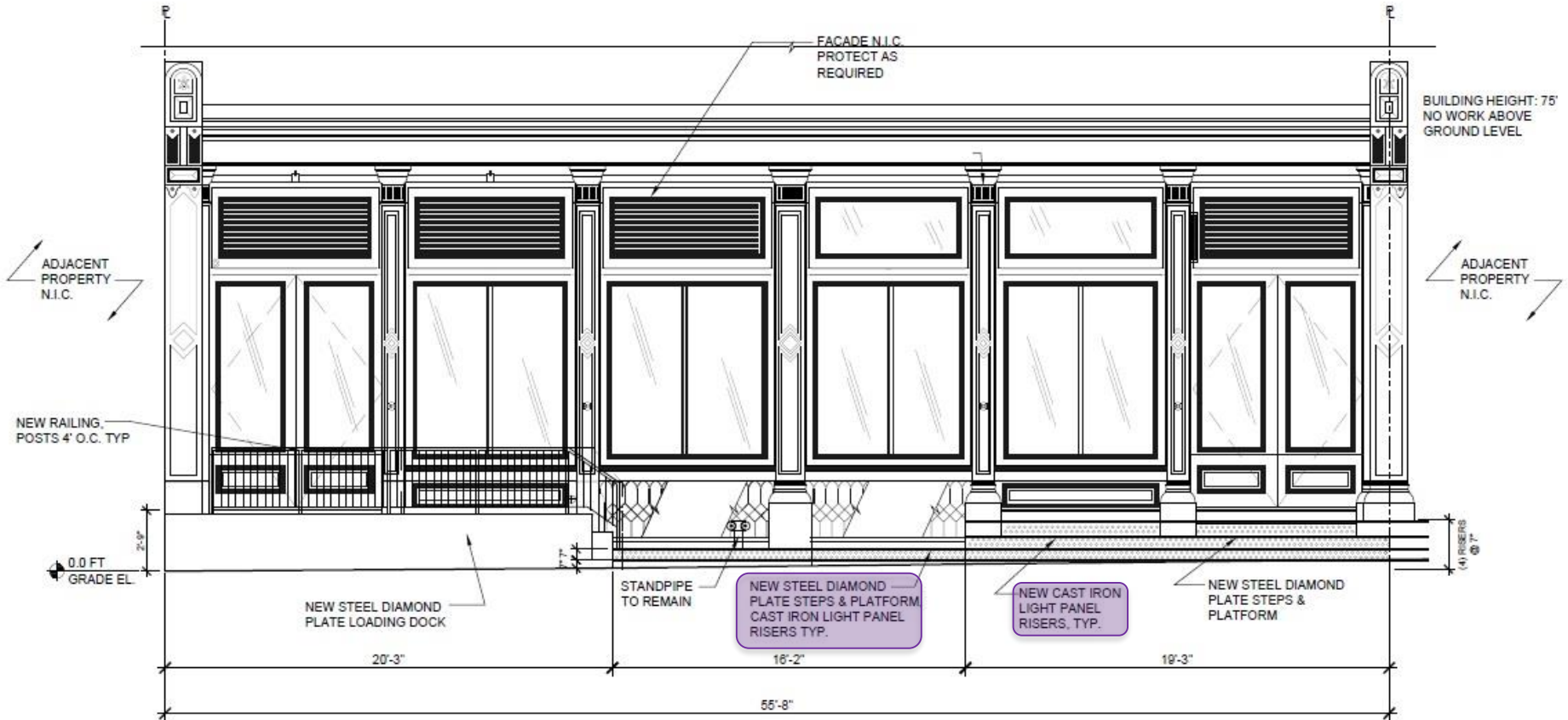

375 West Broadway – Vault and Sidewalk Replacement



- Existing Vault Plan

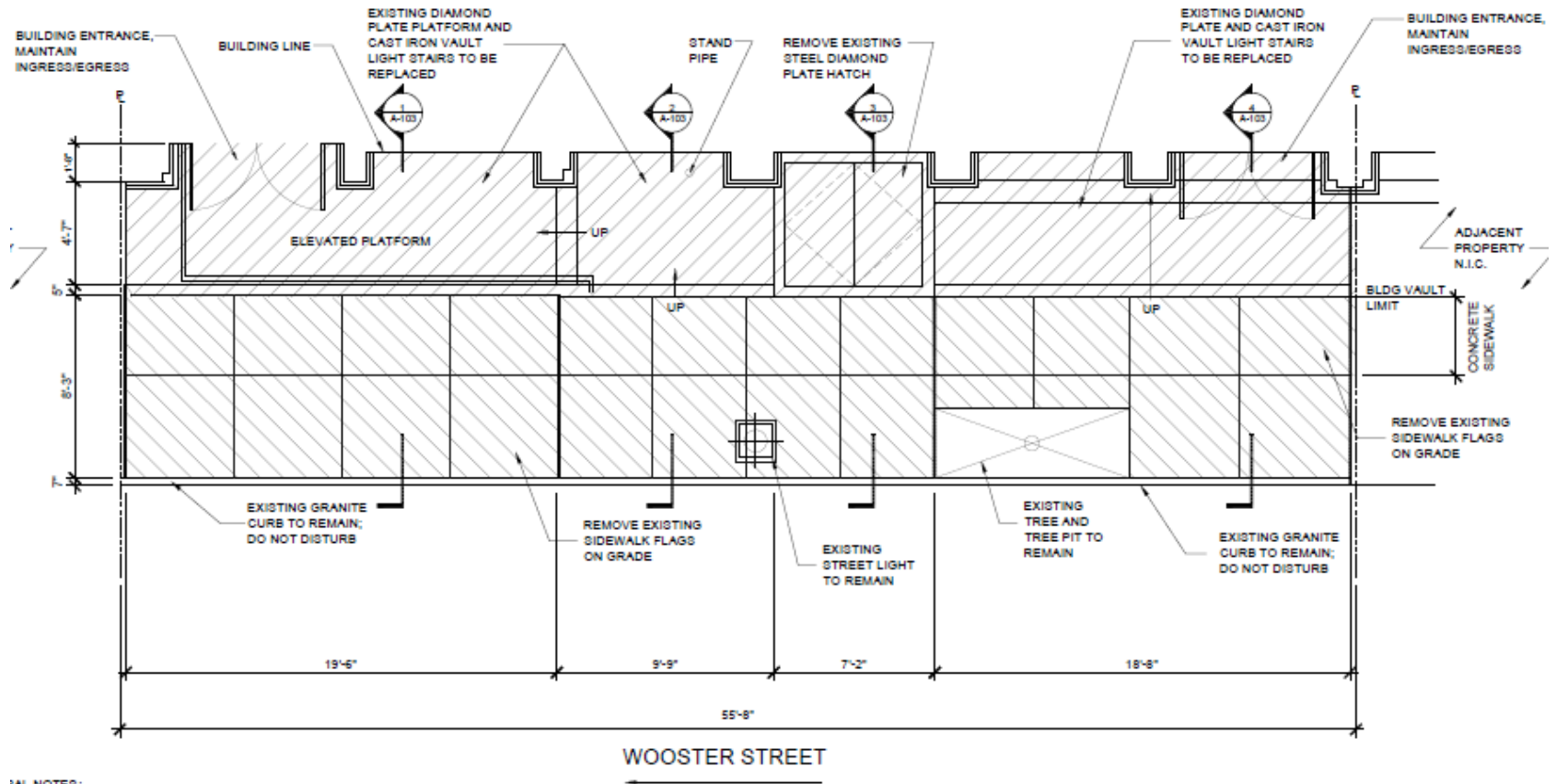

ADDITIONAL NOTES:

375 West Broadway – Vault and Sidewalk Replacement

- Proposed Vault Plan

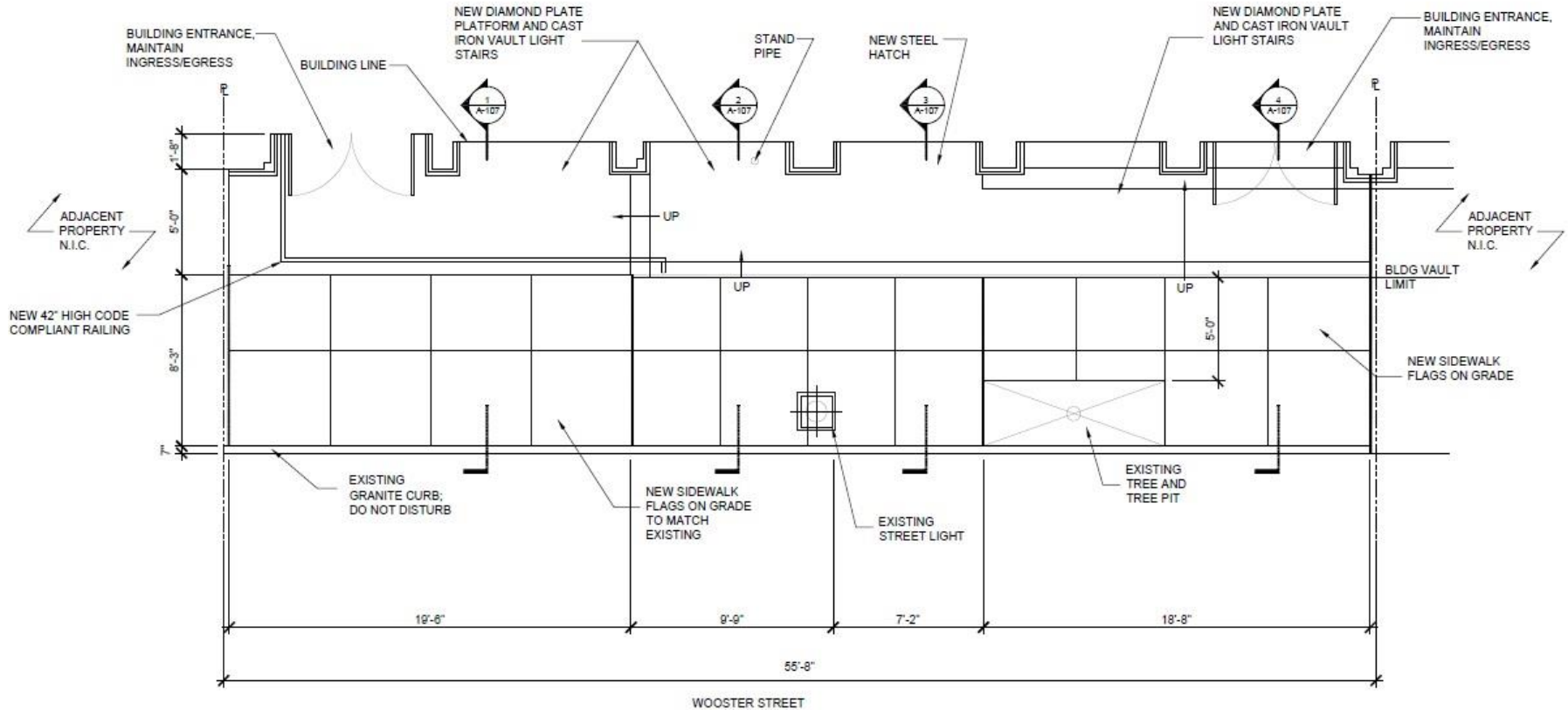

375 West Broadway – Vault and Sidewalk Replacement



- Existing Vault Sections

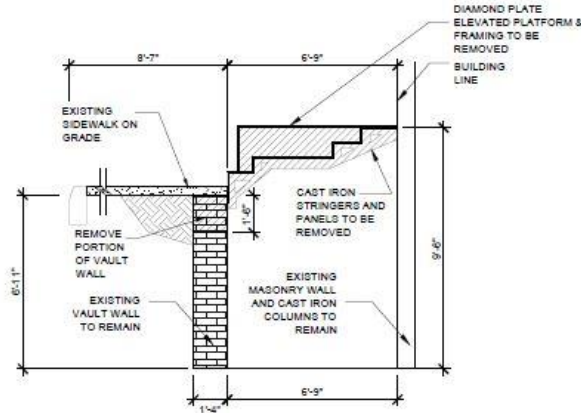

1 EXISTING VAULT SECTION

1/4" = 1"

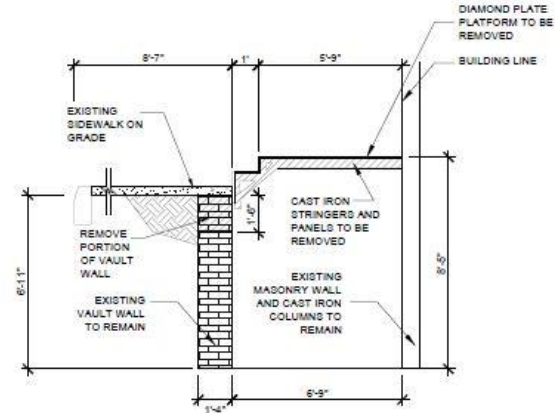

2 EXISTING VAULT SECTION

1/4" = 1"

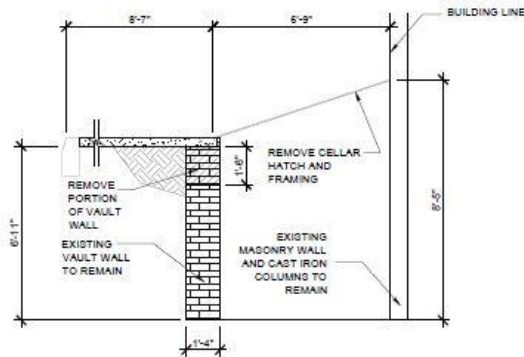

3 EXISTING VAULT HATCH SECTION

1/4" = 1"

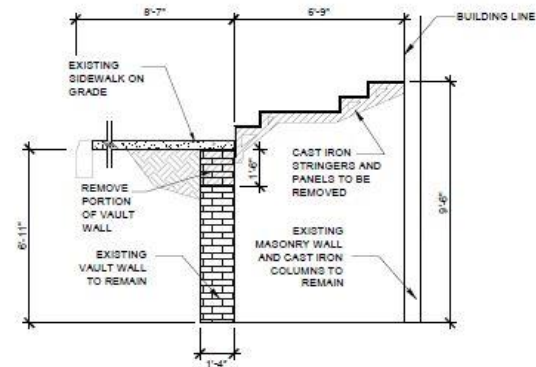

4 EXISTING VAULT SECTION

1/4" = 1"

375 West Broadway – Vault and Sidewalk Replacement



- Proposed Vault Sections

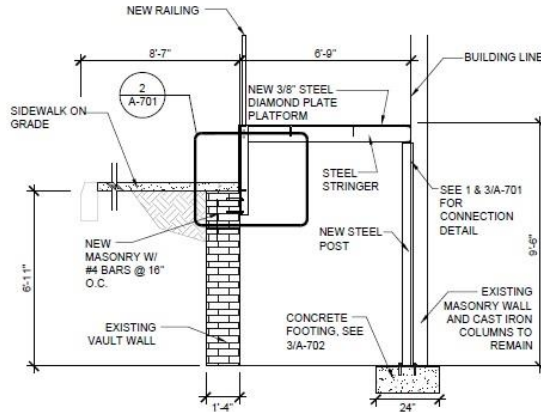

1 PROPOSED VAULT SECTION
1/4" = 1"

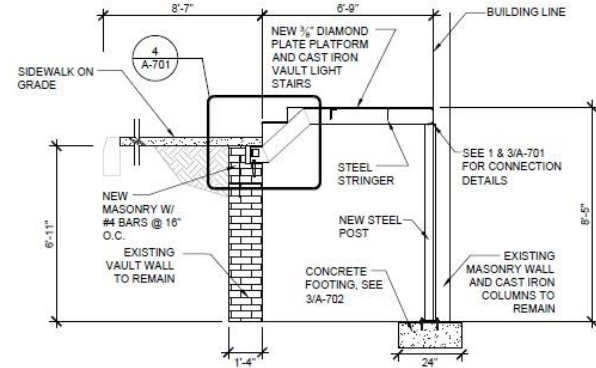

2 PROPOSED VAULT SECTION
1/4" = 1"

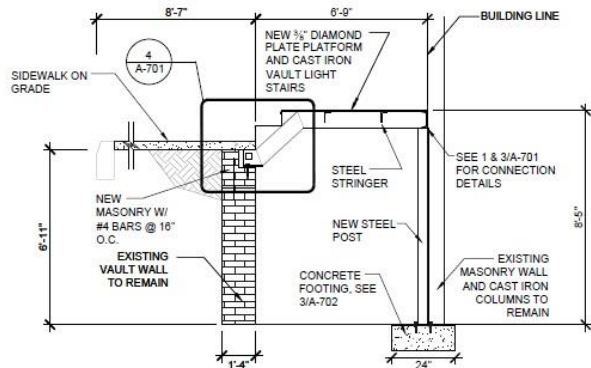

3 PROPOSED VAULT HATCH SECTION
1/4" = 1"

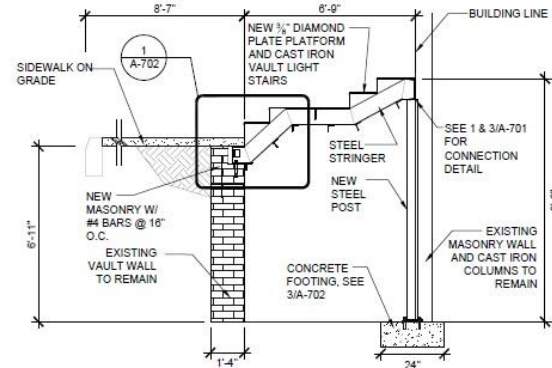

4 PROPOSED VAULT SECTION
1/4" = 1"

375 West Broadway – Vault and Sidewalk Replacement



- **Adjacent sidewalks on Wooster Street**

- Adjacent building to north on Wooster St.
- Note diamond plate throughout



- Adjacent building to south on Wooster St.

375 West Broadway – Vault and Sidewalk Replacement



62 Wooster St.

- **Nearby sidewalk vaults on Wooster Street**
 - Note most with diamond plate only



58 Wooster St.



90 Wooster St.

375 West Broadway – Vault and Sidewalk Replacement



- More vaults in the area



375 West Broadway – Vault and Sidewalk Replacement



- More vaults in the area



375 West Broadway – Vault and Sidewalk Replacement



102 Wooster St.

- More vaults in the area



123 Prince St.



121 Prince St.

375 West Broadway – Vault and Sidewalk Replacement



111 Prince St.

- More vaults in the area



99 Prince St.



99 Prince St.