



# THE CITY RECORD

Official Journal of The City of New York

THE CITY RECORD  
U.S.P.S. 0114-660

Printed on paper containing  
40% post-consumer material

VOLUME CXXXVI NUMBER 10

THURSDAY, JANUARY 15, 2009

PRICE \$4.00

## TABLE OF CONTENTS

### PUBLIC HEARINGS & MEETINGS

City Planning Commission	145
Community Boards	146
Environmental Control Board	146
Equal Employment Practices Commission	146
Landmarks Preservation Commission	146
Transportation	147

### COURT NOTICES

Supreme Court	147
<i>Kings County</i>	147
<i>See Court Notice Maps</i>	154-155

### PROPERTY DISPOSITION

Citywide Administrative Services	148
<i>Division of Municipal Supply Services</i>	148
Police	148

### PROCUREMENT

City University	148
Citywide Administrative Services	148
<i>Division of Municipal Supply Services</i>	148
<i>Vendor Lists</i>	148
Environmental Protection	148
Financial Information Services Agency	149
<i>Contracts Unit</i>	149

Fire	149
Health and Hospitals Corporation	149
Health and Mental Hygiene	149
<i>Agency Chief Contracting Officer</i>	149
Homeless Services	149
<i>Office of Contracts and Procurement</i>	149
Housing Authority	149
<i>Purchasing Division</i>	149
Parks and Recreation	149
<i>Revenue and Concessions</i>	149
Police	149
<i>Contract Administration Unit</i>	149

School Construction Authority	150
<i>Contract Administration</i>	150
Transportation	150
<i>Administration</i>	150

### SPECIAL MATERIALS

Comptroller	150
Conflicts of Interest Board	150
Environmental Protection	154
Housing Preservation and Development	154
Office of the Mayor	154

### READERS GUIDE

### LATE NOTICE

Citywide Administrative Services	154
----------------------------------	-----

## THE CITY RECORD

MICHAEL R. BLOOMBERG, Mayor

MARTHA K. HIRST, Commissioner, Department of Citywide Administrative Services.  
ELI BLACHMAN, Editor of The City Record.

Published Monday through Friday, except legal holidays by the Department of Citywide Administrative Services of the City of New York under Authority of Section 1066 of the New York City Charter.

Subscription—\$500 a year; daily, \$4.00 a copy (\$5.00 by mail) Periodicals Postage Paid at New York, N.Y.  
POSTMASTER: Send address changes to THE CITY RECORD, 1 Centre Street, Room 2208, New York, N.Y. 10007 - 1602

Editorial Office  
1 Centre Street, Room 2208  
New York N.Y. 10007-1602  
Telephone (212) 669-8252

Subscription Changes/Information  
1 Centre Street, Room 2208  
New York N.Y. 10007-1602  
Telephone (212) 669-8252

The City of New York Home Page  
provides Internet access via the WORLD  
WIDE WEB to solicitations and awards  
<http://www.nyc.gov/cityrecord>

## PUBLIC HEARINGS AND MEETINGS

See Also: Procurement; Agency Rules

## CITY PLANNING COMMISSION

### PUBLIC HEARING

NOTICE IS HEREBY GIVEN THAT RESOLUTIONS Have been adopted by the City Planning Commission scheduling public hearings on the following matters to be held at Spector Hall, 22 Reade Street New York, New York, on Wednesday, January 21, 2009, commencing at 10:00 A.M.

### BOROUGH OF THE BRONX No. 1 YANKEE STADIUM PARKING

CD 4 C 090153 PPX  
IN THE MATTER OF an application submitted by the Department of Citywide Administrative Services (DCAS) and the Department of Parks & Recreation (DPR), pursuant to Section 197-c of the New York City Charter, for the disposition to the New York City Economic Development Corporation of six (6) city-owned properties restricted to public parking and accessory uses:

BLOCK	LOT
2539	29
2539	175
2539	191
2539	193
2539	504
2539	p/o 32

### Nos. 2, 3 & 4 BROADWAY PLAZA No. 2

CD 8 C 080014 MMX  
IN THE MATTER OF an application, submitted by the New York City Economic Development Corporation (EDC), and Kingsbridge 230th LLC, pursuant to Sections 197-c and 199 of the New York City Charter, and Section 5-430 *et seq.* of the New York City Administrative Code, for an amendment to the City Map involving:

- the elimination, discontinuance and closing of Kimberly Place, east of Broadway;
- any adjustment of grades necessitated thereby; and
- any acquisition or disposition of real properties related thereto,

in accordance with Map No. 13121 dated April 14, 2008, and signed by the Borough President.

### No. 3

CD 8 C 090146 ZMX  
IN THE MATTER OF an application submitted by Kingsbridge 230th LLC and the NYC Economic Development

Corporation pursuant to Sections 197-c and 201 of the New York City Charter for an amendment of the Zoning Map, Section No. 1d:

- eliminating from within an existing R6 District a C2-3 District bounded by Verveelen Place, the northwesterly boundary line of a Rail Road right-of-way, West 230th Street, and Broadway; and
- changing from an R6 District to a C4-4 District property bounded by Verveelen Place and its southeasterly centerline prolongation, the Major Deegan Expressway, West 230th Street and its southeasterly centerline prolongation, and Broadway;

as shown on a diagram (for illustrative purposes only) dated October 27, 2008, and subject to the conditions of CEQR Declaration E-223.

### No. 4

CD 8 C 090147 PPX  
IN THE MATTER OF an application submitted by the New York City Department of Citywide Administrative Services (DCAS), pursuant to Section 197-c of New York City Charter, for the disposition of one (1) city-owned property located on Block 3266, Lot 13 pursuant to zoning.

### BOROUGH OF MANHATTAN No. 5 567 WEST 183RD STREET

CD 12 C 090071 HAM  
IN THE MATTER OF an application submitted by the Department of Housing Preservation and Development (HPD):

- pursuant to Article 16 of the General Municipal Law of New York State for:
  - the designation of property located at 567 West 183rd Street (Block 2154, Lot 95), as an Urban Development Action Area; and
  - an Urban Development Action Area Project for such area; and
- pursuant to Section 197-c of the New York City Charter for the disposition of such property to a developer selected by HPD;

to facilitate the rehabilitation of an existing three-story residential building, tentatively known as 567 West 183rd Street, with nine residential units, to be developed under the Department of Housing Preservation and Development's Division of Alternative Management Special Projects Program.

### No. 6

### 405-427 WEST 53RD STREET GARAGE

CD 4 C 070305 ZSM  
IN THE MATTER OF an application submitted by 405 West 53rd Development Group, LLC pursuant to Sections 197-c and 201 of the New York City Charter for the grant of a special permit pursuant to Sections 96-111 and 13-561 of the Zoning Resolution to allow an unattended accessory off-street parking garage with a maximum capacity of 37 spaces on portions of the ground floor and cellar of a proposed

residential building on property located at 405-427 West 53rd Street (Block 1063, Lot 17), in a C6-2 District, within the Special Clinton District.

Plans for this proposal are on file with the City Planning Commission and may be seen in Room 3N, 22 Reade Street, New York, N.Y. 10007.

### No. 7 372 BROOME STREET

CD 2 C 070486 ZSM  
IN THE MATTER OF an application submitted by Little Red House, LLC pursuant to Sections 197-c and 201 of the New York City Charter for the grant of a special permit pursuant to Section 74-782 of the Zoning Resolution to modify the use regulations of Section 15-021(e) to allow the conversion to residential use of the 2nd through 6th floors of an existing 6-story building erected prior to December 15, 1961, on property located at 372 Broome Street (Block 480, Lot 37 and p/o of Lot 36), in a C6-2G District, within the Special Little Italy District (Preservation Area A).

Plans for this proposal are on file with the City Planning Commission and may be seen in Room 3N, 22 Reade Street, New York, N.Y. 10007.

### BOROUGH OF QUEENS No. 8 NORTH CORONA 2 REZONING

CD 3 C 090112 ZMQ  
IN THE MATTER OF an application submitted by the Department of City Planning pursuant to Sections 197-c and 201 of the New York City Charter for an amendment of the Zoning Map, Section No(s). 9d, 10a, 10b:

- changing from an R6B District to an R5 District property bounded by:
  - a line 100 feet southerly of 35th Avenue, a line midway between 90th Street and 91st Street, a line 100 feet northerly of 37th Avenue, and 90th Street;
  - a line 100 feet southerly of 34th Avenue, 93rd Street, a line 100 feet northerly of 35th Avenue, 92nd Street, 35th Avenue, a line midway between 93rd Street and 94th Street, a line 100 feet northerly of 37th Avenue, 92nd Street, 37th Avenue, 91st Street, a line 100 feet northerly of 37th Avenue, a line midway between 91st Street and 92nd Street, 35th Avenue, and 91st Street;
  - a line 100 feet southerly of 37th Avenue, a line midway between 90th Street and 91st Street, a line 300 feet northerly of Roosevelt Avenue, Elmhurst Avenue, 92nd Street, 37th Avenue, a line midway between 94th Street and 95th Street, a line 100 feet southeasterly of 37th Avenue, a line midway between Warren Street and Junction Boulevard, a line 100 northerly of Roosevelt Avenue, a line midway between 91st Street and 92nd Street, a line 200 feet northerly of Roosevelt Avenue, and 89th Street;
  - 35th Avenue, 105th Street, 34th Avenue, 112th Street, a line 100 northwesterly and northerly of 37th Avenue, 106th Street, 37th Avenue, 107th Street, 37th Road, 104th Street, a line 100 feet northwesterly of 37th Avenue, and a line 100 feet northeasterly of 99th Street;
  - a line 100 feet southeasterly of 37th Avenue, a line 100 feet southwesterly of 103rd Street, 39th Avenue, 99th Street, a line 100 feet northwesterly of 39th Avenue, and a line 100 feet northeasterly of 99th Street; and

- f. 38th Avenue, a line 125 feet northeasterly of 111th Street, a line 125 feet northwesterly of Roosevelt Avenue, and a line 100 feet northeasterly of 108th Street;
2. changing from an R5 District to an R5A District property bounded by a line 100 feet southerly of Northern Boulevard, a line 100 feet westerly of 101st Street, 34th Avenue, 102nd Street, 35th Avenue, a line midway between Junction Boulevard and 97th Street, the southerly street line of Brice Road and its easterly and westerly prolongation, Junction Boulevard, 34th Avenue, and a line 100 feet westerly of 96th Street;
3. changing from an R6B District to an R5A District property bounded by:
- a. 35th Avenue, a line midway between 91st Street and 92nd Street, a line 100 feet northerly of 37th Avenue, 91st Street, 37th Avenue, 92nd Street, Elmhurst Avenue, a line 300 feet northerly of Roosevelt Avenue, and a line midway between 90th Street and 91st Street;
- b. 35th Avenue, a line 100 feet northeasterly of 99th Street, a line 100 feet northwesterly of 37th Avenue, and a line 100 feet northeasterly of Junction Boulevard;
- c. a line 100 feet southeasterly of 37th Avenue, a line 100 feet northeasterly of 99th Street, a line 100 feet northwesterly of 39th Avenue, a line 100 feet northerly of Roosevelt Avenue, 98th Street, 38th Avenue, and 97th Street;
- d. 37th Road, 107th Street, 37th Drive, a line 100 feet southwesterly of 108th Street, a line 125 feet northwesterly and northerly of Roosevelt Avenue, a line 100 feet northeasterly of 104th Street, 39th Avenue, and 104th Street; and
- e. 37th Avenue, 111th Street, a line 125 feet northwesterly of 38th Avenue, 112th Street, a line midway between 37th Avenue and 38th Avenue, a line 125 feet southwesterly of 114th Street, a line 125 feet northwesterly of Roosevelt Avenue, a line 125 feet northeasterly of 111th Street, 38th Avenue, and a line 100 feet northeasterly of 108th Street; and
4. changing from an R6 District to an R6A District property bounded by:
- a. Astoria Boulevard, 112th Place, a line perpendicular to the easterly street line of 112th Street distant 200 feet southerly (as measured along the street line) from the point of intersection of the easterly street line of 112th Street and the southwesterly street line of Astoria Boulevard, a line midway between 111th Street and 112th Street, a line perpendicular to the westerly street line of 111th Street distant 250 feet southerly (as measured along the street line) from the point of intersection of the westerly street line of 111th Street and the southwesterly street line of Astoria Boulevard, a line midway between 110th Street and 111th Street, a line perpendicular to the easterly street line of 110th Street distant 150 feet southerly (as measured along the street line) from the point of intersection of the easterly street line of 110th Street and the southwesterly street line of Astoria Boulevard, a line midway between 108th Street and 110th Street, the easterly prolongation of the southerly street line of 32nd Avenue, and 108th Street; and
- b. a line 100 northerly of Northern Boulevard, 112th Place, Northern Boulevard, a line 100 feet easterly of 112th Street, a line 100 feet southerly of Northern Boulevard, 96th Street, Northern Boulevard, and 95th Street;

as shown on a diagram (for illustrative purposes only), dated October 6, 2008.

**BOROUGH OF BROOKLYN**  
**No. 9**  
**EAST WINDSOR TERRACE**

**CD 7 C 090197 ZMK**  
**IN THE MATTER OF** an application submitted by the Department of City Planning pursuant to Sections 197-c and 201 of the New York City Charter for an amendment of the Zoning Map, Section Nos. 16d and 22c:

1. changing from an R5 District to a R5B District property bounded by the northeasterly centerline prolongation of Kermit Place, a line 80 feet southwesterly of Coney Island Avenue, Caton Avenue, and East 8th Street;
2. changing from an R6 District to an R5B District property bounded by Caton Place, East 8th Street, Kermit Place, a line 100 feet southwesterly of East 8th Street, a line 125 feet southeasterly of Kermit

Place, East 7th Street, Kermit Place, the northerly prolongation of a line midway between Ocean Parkway and East 7th Street, a line midway between Caton Place and Kermit Place, and a line 100 feet southwesterly of East 8th Street;

3. changing from an R7A District to an R5B District property bounded by a line 75 feet northwesterly of Kermit Place, the northerly prolongation of a line midway between Ocean Parkway and East 7th Street, Kermit Place, and Ocean Parkway;
4. changing from an R6 District to an R6A District property bounded by Kermit Place, East 7th Street, a line 125 feet southeasterly of Kermit Place, a line 100 feet southwesterly of East 8th Street, Kermit Place, East 8th Street, Caton Avenue, and the northerly prolongation of a line midway between Ocean Parkway and East 7th Street; and
5. establishing within a proposed R6A District a C2-4 District bounded by East 8th Street, Caton Avenue, East 7th Street, and a line 125 feet southeasterly of Kermit Place;

within the Special Ocean Parkway District, Borough of Brooklyn, Community District 7, as shown on a diagram (for illustrative purposes only) dated November 17, 2008.

**YVETTE V. GRUEL, Calendar Officer**  
**City Planning Commission**  
**22 Reade Street, Room 2E**  
**New York, New York 10007**  
**Telephone (212) 720-3370**

**j7-21**

**COMMUNITY BOARDS**

■ PUBLIC HEARINGS

PUBLIC NOTICE IS HEREBY GIVEN THAT the following matters have been scheduled for public hearing by Community Boards:

**BOROUGH OF MANHATTAN**

COMMUNITY BOARD NO. 7 - Wednesday, January 21, 2009 at 6:30 P.M., American Bible Society, 1865 Broadway, New York, NY

**#C 090173ZSM**

IN THE MATTER OF an application submitted by Fordham University pursuant to Sections 197-c and 201 of the New York City Charter for the grant of a special permit pursuant to Sections 82-50 and 13-561 to allow an attended accessory parking garage with a maximum capacity of 265 spaces, within the Special Lincoln Square District.

**#C 050269ZSM**

IN THE MATTER OF an application submitted by Fordham University pursuant to Sections 197-c and 201 of the New York City Charter for the grant of a special permit pursuant to Sections 82-50 and 13-561 to allow an attended accessory parking garage with a maximum capacity of 68 spaces on portions of the ground floor, cellar and sub-cellar levels of a proposed mixed-use building, within the Special Lincoln Square District.

**C 050271ZSM**

IN THE MATTER OF an application submitted by Fordham University pursuant to Sections 197-c and 201 of the New York City Charter for the grant of a special permit pursuant to Sections 82-50 and 13-561 to allow an attended accessory parking garage with a maximum capacity of 137 spaces on portions of the ground floor, cellar and subcellar and 2nd sub-cellar level of a proposed mixed-use building in connection with the proposed expansion of Fordham University, within the Special Lincoln Square District.

☛ **j15-21**

**ENVIRONMENTAL CONTROL BOARD**

■ MEETING

The next meeting will take place on Thursday, January 22, 2009 at 66 John Street, 10th Floor Conference Room, New York, NY 10038 at 9:15 A.M. at the call of the Chairman.

**j14-16**

**EQUAL EMPLOYMENT PRACTICES COMMISSION**

■ MEETING

The next meeting of the Equal Employment Practices Commission will be on Thursday, January 15, 2009 at 10:00 A.M. in the Commission's Conference Room/Library located at 40 Rector Street, 14th Floor.

**j9-15**

**LANDMARKS PRESERVATION COMMISSION**

■ PUBLIC HEARINGS

NOTICE IS HEREBY GIVEN that pursuant to the provisions of Title 25, chapter 3 of the Administrative Code of the City of New York (Sections 25-307, 25-308, 25,309, 25-313, 25-318, 25-320) (formerly Chapter 8-A, Sections 207-6.0, 207-7.0, 207-

12.0, 207-17.0, and 207-19.0), on Tuesday, **January 20, 2009 at 9:30 A.M.** in the morning of that day, a public hearing will be held in the Conference Room at 1 Centre Street, 9th Floor, Borough of Manhattan with respect to the following properties and then followed by a public meeting. Any person requiring reasonable accommodation in order to participate in the hearing or attend the meeting should call or write the Landmarks Commission no later than five (5) business days before the hearing or meeting.

**CERTIFICATE OF APPROPRIATENESS**

**BOROUGH OF THE BRONX 09-3008 - Block VARIOUS, lot VARIOUS-**

Various Addresses - Fieldston Historic District  
A Romantic style planned suburb laid out in 1914 by engineer Albert Wheeler based on recommendations made by Frederick Law Olmsted and James R. Croe. The Historic District is characterized by an eclectic variety of residential buildings and styles including variants of the Colonial Revival, Craftsman, various picturesque revivals styles including Medieval, Tudor, and Mediterranean, as well as formal modernist houses. Application is to establish a Master Plan to govern certain types of alterations to buildings, other improvements and landscape improvements within the Fieldston Historic District, authorizing the staff to approve such work if it meets the requirements of the Master Plan.

**PROPOSED RULEMAKING**

A proposal to adopt the Fieldston Historic District Implementation Rules for a proposed master plan for certain alterations to improvement in the Fieldston Historic District pursuant to the City Administrative Procedures Act.

**CERTIFICATE OF APPROPRIATENESS**

**BOROUGH OF THE BRONX 08-0832 - Block 5818, lot 2015-4640 Livingston Avenue - Fieldston Historic District**  
A free standing house built circa 1947-1953 and altered in 1959. Application is to construct additions and alter facades. Zoned R1-2, NA-2.

**BINDING REPORT**

**BOROUGH OF THE BRONX 09-4753 - Block 5937, lot 441-675 West 252nd Street - Wave Hill House - Individual Landmark**  
A Federal style manor house built c. 1850, with additions and alterations in the Georgian and Gothic Eclectic styles in the late 19th and early 20th centuries. Application is to install a barrier-free access entry, ramp, and egress platform.

**CERTIFICATE OF APPROPRIATENESS**

**BOROUGH OF QUEENS 09-4586 - Block 8038, lot 69-202 Shore Road - Douglaston Historic District**  
An English Cottage style free standing house designed by Werner and Windolph and built in 1919, with later additions. Application is to demolish the mid-20th century additions, and construct new additions and install a new curb cut. Zoned R1-1.

**MODIFICATION OF USE AND BULK**

**BOROUGH OF MANHATTAN 09-5184 - Block 1150, lot 7-161 West 78th Street - Upper West Side - Central Park West Historic District**  
A Renaissance Revival style rowhouse with neo-Grec elements designed by Thom & Wilson and built in 1890. Application is to request that the Landmarks Preservation Commission issue a report to the City Planning Commission relating to an application for a Modification of Bulk Pursuant to Section 74-711 of the Zoning Resolution.

**CERTIFICATE OF APPROPRIATENESS**

**BOROUGH OF MANHATTAN 08-8519 - Block 1251, lot 117-303 West 90th Street - Riverside-West End Historic District**  
A Elizabethan Renaissance style rowhouse designed by Clarence True, and built in 1898-99. Application is to construct rear and rooftop additions. Zoned R10A.

**CERTIFICATE OF APPROPRIATENESS**

**BOROUGH OF MANHATTAN 09-4942 - Block 1405, lot 8-115 East 70th Street - Upper East Side Historic District**  
A neo-French Classic style residence designed by Patrick J. Murray and built in 1921-22. Application is to legalize the installation of a metal lattice at the roof and entryway light fixtures without Landmarks Preservation Commission permits.

**CERTIFICATE OF APPROPRIATENESS**

**BOROUGH OF MANHATTAN 09-5841 - Block 1505, lot 33-75 East 93rd Street - (former) George F. Baker House - Individual Landmark**  
A modified Federal style residence designed by Delano & Aldrich and built in 1917-18. Application is to construct a rooftop addition and modify the courtyard. Zoned R10.

**CERTIFICATE OF APPROPRIATENESS**

**BOROUGH OF MANHATTAN 08-7636 - Block 894, lot 37-149 East 38th Street - George S. Bowdoin Stable-Individual Landmark**  
A Dutch Revival style stable designed by Ralph S. Townsend and built in 1902. Application is to install signage. Zoned R8B.

**CERTIFICATE OF APPROPRIATENESS**

**BOROUGH OF MANHATTAN 09-5510 - Block 848, lot 68-901 Broadway - (former) Lord & Taylor Building - Individual Landmark - Ladies' Mile Historic District**  
A French Second Empire style commercial building designed by James H. Giles and built in 1870. Application is to install storefront infill, louvers and a metal canopy.

**CERTIFICATE OF APPROPRIATENESS**

**BOROUGH OF MANHATTAN 09-5097 - Block 485, lot 5-66 Greene Street - SoHo-Cast Iron Historic District**  
A store building designed by J.B. Snook and built in 1873. Application is to install storefront infill, modify fire escape, replace windows, and legalize the removal of a loading dock and installation of stairs entrance without Landmarks Preservation Commission permits.

## BINDING REPORT

BOROUGH OF MANHATTAN 09-5939 - Block 549, lot 1,2,3,4-  
Washington Square Park - Greenwich Village Historic District  
A public park built in 1826 with subsequent alterations. Application is to construct a stage platform.

## CERTIFICATE OF APPROPRIATENESS

BOROUGH OF MANHATTAN 07-4285 - Block 591, lot 40-49-53 1/2 Grove Street, aka 317-321 Bleecker Street - Greenwich Village Historic District  
Two six-story buildings designed by Herter Brothers and built in 1889. Application is to replace windows.

## CERTIFICATE OF APPROPRIATENESS

BOROUGH OF MANHATTAN 09-2511 - Block 698, lot 18-515-521 West 26th Street - West Chelsea Historic District  
A vernacular brick factory building designed by Abraham Ratner and built in 1921; a daylight factory building designed by Rouse & Goldstone and built in 1911; and a brick daylight factory building with Arts and Crafts style elements designed by Harris H. Uris and built in 1913-14. Application is to construct rooftop additions. Zoned M1-5.

## CERTIFICATE OF APPROPRIATENESS

BOROUGH OF MANHATTAN 09-4697 - Block 100, lot 3-150 Nassau Street - American Tract Society Building - Individual Landmark  
A steel skeletal-frame skyscraper with Romanesque and Renaissance Revival-style elements built in 1894-95 and designed by Robert Henderson Robertson. Application is to replace windows.

## CERTIFICATE OF APPROPRIATENESS

BOROUGH OF MANHATTAN 09-5413 - Block 173, lot 19 & 20-78 and 80-82 Leonard Street - Tribeca East Historic District  
A Second Empire style store and loft building, built in 1864-1865, and an Italianate style store and loft building, designed by James H. Giles and built in 1860-1862. Application is to construct a rooftop addition. Zoned C6-ZA.

## CERTIFICATE OF APPROPRIATENESS

BOROUGH OF MANHATTAN 09-1277 - Block 196, lot 7-412 Broadway - Tribeca East Historic District  
A neo-Renaissance style store and loft building designed by Frederick P. Platt and built in 1910. Application is to replace windows.

## CERTIFICATE OF APPROPRIATENESS

BOROUGH OF MANHATTAN 09-2923 - Block 136, lot 8-48 Warren Street - Tribeca South Historic District Extension  
An Italianate style store and loft building built c.1855. Application is to replace windows.

## CERTIFICATE OF APPROPRIATENESS

BOROUGH OF BROOKLYN 09-4001 - Block 260, lot 52-306 Hicks Street - Brooklyn Heights Historic District  
An Anglo-Italianate style row house constructed in 1853. Application is to alter window openings and replace windows.

j6-20

## TRANSPORTATION

## PUBLIC HEARINGS

**NOTICE IS HEREBY GIVEN**, pursuant to law, that the following proposed revocable consents, have been scheduled for a public hearing by the New York City Department of Transportation. The hearing will be held at 40 Worth Street, Room 814 commencing at 2:00 p.m. on Wednesday, January 21, 2009. Interested Parties can obtain copies of proposed agreements or request sign-language interpreters (with at least seven days prior notice) at 40 Worth Street, 9th Floor South, New York, NY 10013, or by calling (212) 442-8040.

**#1** In the matter of a proposed revocable consent authorizing 39 West 76th Street Property LLC to construct, maintain and use a fenced-in planted area and steps on the north sidewalk of West 76th Street, east of Columbus Avenue, in the Borough of Manhattan. The proposed revocable consent is for a term of ten years from the Date of Approval by the Mayor to June 30, 2019, and provides among other terms and conditions, for compensation payable to the City according to the following schedule:

From the Approval Date to June 30, 2019 - \$25/per annum

the maintenance of a security deposit in the sum of \$5,000, and the filing of an insurance policy in the minimum amount of \$250,000/\$1,000,000 for bodily injury and property damage for each occurrence in the aggregate amount of \$100,000.

**#2** In the matter of a proposed modification of revocable consent authorizing David Ellis Real Estate, L.P to construct, maintain and use two additional stairs under and along the north sidewalk of West 13th Street, east of Ninth Avenue, and under and along the east sidewalk of Ninth Avenue north of West 13th Street, in the Borough of Manhattan. The proposed revocable consent is for a term of six years from the Date of Approval by the Mayor to June 30, 2015, and provides among other terms and conditions, for compensation payable to the City according to the following schedule:

From the Approval Date to June 30, 2009 compensation is increased by \$4,491 per annum

For the period July 1, 2009 to June 30, 2010 - \$10,746  
For the period July 1, 2010 to June 30, 2011 - \$11,020  
For the period July 1, 2011 to June 30, 2012 - \$11,294  
For the period July 1, 2012 to June 30, 2013 - \$11,568  
For the period July 1, 2013 to June 30, 2014 - \$11,842  
For the period July 1, 2014 to June 30, 2015 - \$12,106

the maintenance of a security deposit in the sum of \$12,200, and the filing of an insurance policy in the minimum amount of \$1,250,000/\$5,000,000 for bodily injury and property damage for each occurrence in the aggregate amount of \$1,000,000.

**#3** In the matter of a proposed revocable consent authorizing One Bryant Park LLC to construct, maintain and use bollards on the sidewalks of the site bounded by 6th Avenue, 42nd and 43rd Streets, in the Borough of Manhattan. The proposed revocable consent is for a term of ten years from the Date of Approval by the Mayor to June 30, 2019, and provides among other terms and conditions, for compensation payable to the City according to the following schedule:

There shall be no compensation required for this revocable consent. the maintenance of a security deposit in the sum of \$10,000, and the filing of an insurance policy in the minimum amount of \$250,000/\$1,000,000 for bodily injury and property damage for each occurrence in the aggregate amount of \$100,000.

**#4** In the matter of a proposed modification of revocable consent authorizing The New York Historical Society to remove existing Structure and to construct, maintain and use a stoop, accessibility ramp and sidewalk light fixtures, together with electrical conduits, on the south sidewalk of West 77th Street, west of Central Park West, and a stoop, two kiosks, and sidewalk light fixtures, together with electrical conduits, on the west sidewalk of Central Park West, between West 76th and West 77th Street, and a sidewalk light fixtures, together with electrical conduits, on the north sidewalk of West 77th Street, west of Central Park West, in the Borough of Manhattan. The proposed revocable consent is for a term of eight years from the Date of Approval by the Mayor to June 30, 2017 and provides, among other terms and conditions, for compensation payable to the City according to the following schedule:

For the period from July 1, 2007 to June 30, 2017 - \$25/per annum.

the maintenance of a security deposit in the sum of \$5,000, and the filing of an insurance policy in the minimum amount of \$500,000/\$2,000,000 for bodily injury and property damage for each occurrence in the aggregate amount of \$200,000.

d30-j21

**NOTICE IS HEREBY GIVEN**, pursuant to law, that the following proposed revocable consents, have been scheduled for a public hearing by the New York City Department of Transportation. The hearing will be held at 40 Worth Street, Room 814 commencing at 2:00 P.M. on Wednesday, February 4, 2009. Interested Parties can obtain copies of proposed agreements or request sign-language interpreters (with at least seven days prior notice) at 40 Worth Street, 9th Floor South, New York, NY 10013, or by calling (212) 442-8040.

**#1** In the matter of a proposed revocable consent authorizing Michael Dimitriou to maintain and use a fenced-in area on the north sidewalk of Powell's Cove Boulevard west of 158th Street, in the Borough of Queens. The proposed revocable consent is for a term of ten years from the Date of Approval by the Mayor to June 30, 2019 and provides, among other terms and conditions, for compensation payable to the City according to the following schedule:

From the Approval Date to June 30, 2019 - \$100/per annum

the maintenance of a security deposit in the sum of \$3,000, and the filing of an insurance policy in the minimum amount of \$250,000/\$1,000,000 for bodily injury and property damage for each occurrence in the aggregate amount of \$100,000.

**#2** In the matter of a proposed revocable consent authorizing The Promenade Condominium to maintain and use lampposts, together with electrical conduits, on the north and south sidewalks of East 76th Street, between York Avenue and Franklin D. Roosevelt Drive, in the Borough of Manhattan. The proposed revocable consent is for a term beginning July 1, 2008 to June 30, 2018 and provides, among other terms and conditions, for compensation payable to the City according to the following schedule:

For the period July 1, 2008 to June 30, 2018 - \$900/annum

the maintenance of a security deposit in the sum of \$1,000, and the filing of an insurance policy in the minimum amount of \$250,000/\$1,000,000 for bodily injury and property damage for each occurrence in the aggregate amount of \$100,000.

**#3** In the matter of a proposed revocable consent authorizing Staten Island Aid for Retarded Children Inc. d/b/a Community Resources for the Developmentally Disable to continue to maintain and use a force main, together with manholes, and a sanitary sewer under, across and along Victory Boulevard, from Signs Road to Graham Avenue, in the Borough of Staten Island. The proposed revocable consent is for a term beginning July 1, 2008 to June 30, 2018 and provides, among other terms and conditions, for compensation payable to the City according to the following schedule:

For the period July 1, 2008 to June 30, 2009 - \$13,701  
For the period July 1, 2009 to June 30, 2010 - \$14,100  
For the period July 1, 2010 to June 30, 2011 - \$14,499  
For the period July 1, 2011 to June 30, 2012 - \$14,898  
For the period July 1, 2012 to June 30, 2013 - \$15,297  
For the period July 1, 2013 to June 30, 2014 - \$15,696  
For the period July 1, 2014 to June 30, 2015 - \$16,095  
For the period July 1, 2015 to June 30, 2016 - \$16,494  
For the period July 1, 2016 to June 30, 2017 - \$16,893  
For the period July 1, 2017 to June 30, 2018 - \$17,292

the maintenance of a security deposit in the sum of \$17,300, and the filing of an insurance policy in the minimum amount of \$250,000/\$1,000,000 for bodily injury and property damage for each occurrence in the aggregate amount of \$100,000.

**#4** In the matter of a proposed revocable consent authorizing The Cooper Union for the Advancement of Science and Art to continue to maintain and use conduits under and across Astor Place, east of Fourth Avenue, in the Borough of Manhattan. The proposed revocable consent is for a term beginning July 1, 2009 to June 30, 2019 and provides, among other terms and conditions, for compensation payable to the City according to the following schedule:

For the period July 1, 2009 to June 30, 2010 - \$7,040  
For the period July 1, 2010 to June 30, 2011 - \$7,245  
For the period July 1, 2011 to June 30, 2012 - \$7,450  
For the period July 1, 2012 to June 30, 2013 - \$7,655  
For the period July 1, 2013 to June 30, 2014 - \$7,860  
For the period July 1, 2014 to June 30, 2015 - \$8,065  
For the period July 1, 2015 to June 30, 2016 - \$8,270  
For the period July 1, 2016 to June 30, 2017 - \$8,475  
For the period July 1, 2017 to June 30, 2018 - \$8,680  
For the period July 1, 2018 to June 30, 2019 - \$8,885

the maintenance of a security deposit in the sum of \$8,900, and the filing of an insurance policy in the minimum amount of \$250,000/\$1,000,000 for bodily injury and property damage for each occurrence in the aggregate amount of \$100,000.

**#5** In the matter of a proposed revocable consent authorizing The Cooper Union for the Advancement of Science and Art to continue to maintain and use conduits under and along the easterly sidewalk of Fourth Avenue, between East 7th Street and Astor Place, in the Borough of Manhattan. The proposed revocable consent is for a term beginning July 1, 2009 to June 30, 2019 and provides, among other terms and conditions, for compensation payable to the City according to the following schedule:

For the period July 1, 2009 to June 30, 2010 - \$5,363  
For the period July 1, 2010 to June 30, 2011 - \$5,524  
For the period July 1, 2011 to June 30, 2012 - \$5,685  
For the period July 1, 2012 to June 30, 2013 - \$5,846  
For the period July 1, 2013 to June 30, 2014 - \$6,007  
For the period July 1, 2014 to June 30, 2015 - \$6,168  
For the period July 1, 2015 to June 30, 2016 - \$6,329  
For the period July 1, 2016 to June 30, 2017 - \$6,490  
For the period July 1, 2017 to June 30, 2018 - \$6,651  
For the period July 1, 2018 to June 30, 2019 - \$6,812

the maintenance of a security deposit in the sum of \$6,900, and the filing of an insurance policy in the minimum amount of \$250,000/\$1,000,000 for bodily injury and property damage for each occurrence in the aggregate amount of \$100,000.

j14-f4

## COURT NOTICES

## SUPREME COURT

## NOTICE

**KINGS COUNTY  
IA PART 74  
NOTICE OF PETITION  
INDEX NUMBER 33132/08**

In the Matter of the CITY OF NEW YORK, relative to acquiring title in fee simple, to real property needed for the **FIFTH AMENDED BROOKLYN CENTER URBAN RENEWAL PROJECT, PHASE 2** within an area bounded by Fulton Street, Duffield Street, Willoughby Street, and Albee Square, and a second area bounded by Lafayette Avenue, Rockwell Place, Fulton Street and Ashland Place, both of which areas are located in the Borough of Brooklyn, City and State of New York.

**PLEASE TAKE NOTICE** that the Corporation Counsel of the City of New York intends to make application to the Supreme Court of the State of New York, Kings County, IA Part 74, for certain relief.

The application will be made before Justice Abraham Geroges at 360 Adams Street, in the Borough of Brooklyn, City and State of New York, on January 23, 2009, at 9:30 A.M., or as soon thereafter as counsel can be heard.

The application is for an order:

- 1) authorizing the City to file an acquisition map in the Office of the City Register;
- 2) directing that upon the filing of said map, title to the property sought to be acquired shall vest in the City;
- 3) providing that just compensation therefor be ascertained and determined by the Supreme Court without a jury; and
- 4) providing that notices of claim must be served and filed within one calendar year from the vesting date.

The City of New York, in this proceeding, intends to acquire title in fee simple to certain real property where not heretofore acquired for the same purpose, for the Fifth Amended Brooklyn Center Urban Renewal Project, Phase 2 in the Borough of Brooklyn, City and State of New York.

The real property to be acquired consists of the following parcels, located in Brooklyn New York, as shown on the Brooklyn Tax Map, as of May 19th, 2008:

Damage Parcel	Tax Block	Tax Lot
10	146	16
11	146	17
12	146	29
13	146	34
14	146	35
15	146	36
16	146	41
17	146	42
18	2107	15
19	2107	24
20	2107	30
21	2107	36
22	2107	40
23	2107	41

The property shall be acquired subject to encroachments, if any, of the structures, improvements and appurtenances standing or maintained partly upon the above described parcels and partly upon the lands and premises adjoining the same, as long as such encroachments shall stand. Tax Block 146 Lots 41 and 42 (Damage Parcels 16 and 17) are affected by a zoning lot merger agreement filed with the New York City Register August 30, 2007, CRFN 2007000449340.

The parcels to be acquired in Block 2107 shall be acquired subject to any and all easements that burden these parcels and benefit the Metropolitan Transportation Authority and New York City Transit.

Surveys, maps or plans of the property to be acquired are on file in the office of the Corporation Counsel of the City of New York, 100 Church Street, New York, New York 10007.

**PLEASE TAKE FURTHER NOTICE THAT**, pursuant to EDPL § 402(B)(4), any party seeking to oppose the acquisition must interpose a verified answer, which must contain specific denial of each material allegation of the petition controverted by the opponent, or any statement of new matter deemed by the opponent to be a defense to the proceeding. Pursuant to CPLR 403, said answer must be served upon the office of the Corporation Counsel at least seven (7) days before the date that the petition is noticed to be heard.

Dated: December 8, 2008, New York, New York  
MICHAEL A. CARDOZO  
Corporation Counsel of the City of New York  
100 Church Street  
New York, New York 10007  
Tel. (212) 788-0715

SEE MAPS ON BACK PAGES

j5-20

## PROPERTY DISPOSITION

### CITYWIDE ADMINISTRATIVE SERVICES

#### DIVISION OF MUNICIPAL SUPPLY SERVICES

##### ■ AUCTION

#### PUBLIC AUCTION SALE NUMBER 09001-O and P

NOTICE IS HEREBY GIVEN of a bi-weekly public auction of City fleet vehicles consisting of cars, vans, light duty vehicles, trucks, heavy equipment and miscellaneous automotive equipment to be held on Wednesday, February 4, 2009 (SALE NUMBER 09001-P). This auction is held every other Wednesday unless otherwise notified. Viewing is on auction day only from 8:30 A.M. until 9:00 A.M. The auction begins at 9:00 A.M.

NOTE: The auction scheduled for Wednesday, January 21, 2009 (SALE NUMBER 09001-O), has been cancelled.

LOCATION: 570 Kent Avenue, Brooklyn, NY (in the Brooklyn Navy Yard between Taylor and Clymer Streets).

A listing of vehicles to be offered for sale in the next auction can be viewed on our website, on the Friday prior to the sale date at: <http://www.nyc.gov/auctions>

Terms and Conditions of Sale can also be viewed at this site. For further information, please call (718) 417-2155 or (718) 625-1313.

☛ j15-f4

### POLICE

#### OWNERS ARE WANTED BY THE PROPERTY CLERK DIVISION OF THE NEW YORK CITY POLICE DEPARTMENT.

The following listed property is in the custody, of the Property Clerk Division without claimants.

Recovered, lost, abandoned property, property obtained from prisoners, emotionally disturbed, intoxicated and deceased persons; and property

obtained from persons incapable of caring for themselves.

**Motor vehicles, boats, bicycles, business machines, cameras, calculating machines, electrical and optical property, furniture, furs, handbags, hardware, jewelry, photographic equipment, radios, robes, sound systems, surgical and musical instruments, tools, wearing apparel, communications equipment, computers, and other miscellaneous articles.**

#### INQUIRIES

Inquiries relating to such property should be made in the Borough concerned, at the following office of the Property Clerk.

#### FOR MOTOR VEHICLES

(All Boroughs):

- \* College Auto Pound, 129-01 31 Avenue, College Point, NY 11354, (718) 445-0100
- \* Gowanus Auto Pound, 29th Street and 2nd Avenue, Brooklyn, NY 11212, (718) 832-3852
- \* Erie Basin Auto Pound, 700 Columbia Street, Brooklyn, NY 11231, (718) 246-2029

#### FOR ALL OTHER PROPERTY

- \* Manhattan - 1 Police Plaza, New York, NY 10038, (212) 374-4925.
- \* Brooklyn - 84th Precinct, 301 Gold Street, Brooklyn, NY 11201, (718) 875-6675.
- \* Bronx Property Clerk - 215 East 161 Street, Bronx, NY 10451, (718) 590-2806.
- \* Queens Property Clerk - 47-07 Pearson Place, Long Island City, NY 11101, (718) 433-2678.
- \* Staten Island Property Clerk - 1 Edgewater Plaza, Staten Island, NY 10301, (718) 876-8484.

j1-d31

## PROCUREMENT

*"The City of New York is committed to achieving excellence in the design and construction of its capital program, and building on the tradition of innovation in architecture and engineering that has contributed to the City's prestige as a global destination. The contracting opportunities for construction/construction services and construction-related services that appear in the individual agency listings below reflect that commitment to excellence."*

### CITY UNIVERSITY

#### ■ SOLICITATIONS

##### Goods

**HYBRID BUS** – Request for Information – PIN# 042CSI6382JB – DUE 02-02-09 – BL Bidders List/ Sources Sought. The College of Staten Island is seeking sources to provide an Azure Dynamics Electric Hybrid Citibus, Vehicle Class 4. Interested parties must be able to demonstrate proof that proposed vehicle can pass the "Altoona Bus Test", the Federal Transit Administration's testing program. In addition to meeting or exceeding all applicable Federal, NYS and Local specifications and regulations, the proposed vehicle must be supplied with the following features: "Automatic Anti-Idle", "Engine-Off Full Auxiliary Access," with a capacity of 20 Passenger + 4 and 2 WC's.

If you are interested in providing the Hybrid Bus, and meet all of the listed requirements, please submit in writing, either by letter or by fax, both (a) your expression of interest; and (b) evidence of supporting relevant documentation that fully satisfy each of the above listed requirements, by no later than the due date set forth below. Reference "Bid Number 6382" on all correspondence. Expression of interest due date and time: January 26, 2009 at 10:00 A.M.

Use the following address unless otherwise specified in notice, to secure, examine or submit bid/proposal documents, vendor pre-qualification and other forms; specifications/blueprints; other information; and for opening and reading of bids at date and time specified above.  
College of Staten Island, Purchasing Department  
2800 Victory Boulevard, Building 3A-102, Staten Island  
New York 10314. Sandra Lebow (718) 982-2450.

☛ j15

### CITYWIDE ADMINISTRATIVE SERVICES

#### DIVISION OF MUNICIPAL SUPPLY SERVICES

##### ■ SOLICITATIONS

##### Goods

**DEPT. OF CORRECTION, KOSHER PASSOVER DINNERS - 2009** – Competitive Sealed Bids – PIN# 8570900567 – DUE 01-21-09 AT 10:00 A.M.

Use the following address unless otherwise specified in notice, to secure, examine or submit bid/proposal documents, vendor pre-qualification and other forms; specifications/blueprints; other information; and for opening and reading of bids at date and time specified above.  
Department of Citywide Administrative Services  
1 Centre Street, 18th Floor, New York, NY 10007.  
Jeanette Megna (212) 669-8562.

☛ j15

##### Services (Other Than Human Services)

**AUTO BODY REPAIR SERVICES IN THE FIVE BOROUGHES** – Competitive Sealed Bids – DUE 02-10-09 AT 10:00 A.M.  
PIN# 856095500322 - Vehicles Stationed in Manhattan South  
PIN# 856095500323 - Vehicles Stationed in Brooklyn North  
PIN# 856095500324 - Vehicles Stationed in Manhattan North  
PIN# 856095500325 - Vehicles Stationed in The Bronx and Queens

PIN# 856095500326 - Vehicles Stationed in Staten Island and Brooklyn South

**PROJECT DESCRIPTION:** Specifications - This procurement is for five (5) separate three-year bid agreement(s) for auto body repair services for DCAS. DCAS client and other Mayoral Agencies' light and medium duty vehicles. Bid Bond Security: not applicable. Contract Duration: Three years. Performance and Payment Bonds required: not applicable. Contract Amounts not to exceed:  
PIN# 856095500322 - Manhattan South - \$600,000  
PIN# 856095500323 - Brooklyn North - \$600,000  
PIN# 856095500324 - Manhattan North - \$600,000  
PIN# 856095500325 - The Bronx and Queens - \$400,000  
PIN# 856095500326 - Staten Island and Brooklyn South - \$200,000

NOTE: There is a \$35.00 fee for each PIN#, payable by money order or company check.

Bid packages must be obtained in person between the hours of 9:00 A.M. to 4:00 P.M. Bid package deposit is \$35.00 per set. Company check or money orders are acceptable (NO CASH) and are made payable to: DCAS. For bid results and availability of bid packages, call the plan desk at (212) 669-3499. Vendor Source ID#: 57542.

Use the following address unless otherwise specified in notice, to secure, examine or submit bid/proposal documents, vendor pre-qualification and other forms; specifications/blueprints; other information; and for opening and reading of bids at date and time specified above.  
Department of Citywide Administrative Services  
1 Centre Street, 18th Floor, Room 1860, New York, NY 10007.  
Erkan Solak (212) 669-3530.

☛ j15

#### ■ AWARDS

##### Goods

**HELMETS, DISORDER CONTROL, NYPD** – Competitive Sealed Bids – PIN# 857801096 – AMT: \$804,875.00 – TO: Diaphorm Technologies LLC, DBA Max Pro Police and Armor, 4181 West 5800 North, Mountain Green, UT 84050.  
● **BAGS, RESUSCITATOR** – Competitive Sealed Bids – PIN# 857801146 – AMT: \$546,840.00 – TO: Ambu Inc., 6740 Baymeadow Drive, Glen Burnie, MD 21060.

☛ j15

#### ■ VENDOR LISTS

##### Goods

**ACCEPTABLE BRAND LIST** – In accordance with PPB Rules, Section 2-05(c)(3), the following is a list of all food items for which an Acceptable Brands List has been established.

1. Mix, Biscuit - AB-14-1:92
2. Mix, Bran Muffin - AB-14-2:91
3. Mix, Corn Muffin - AB-14-5:91
4. Mix, Pie Crust - AB-14-9:91
5. Mixes, Cake - AB-14-11:92A
6. Mix, Egg Nog - AB-14-19:93
7. Canned Beef Stew - AB-14-25:97
8. Canned Ham Shanks - AB-14-28:91
9. Canned Corned Beef Hash - AB-14-26:94
10. Canned Boned Chicken - AB-14-27:91
11. Canned Corned Beef - AB-14-30:91
12. Canned Ham, Cured - AB-14-29:91
13. Complete Horse Feed Pellets - AB-15-1:92
14. Canned Soups - AB-14-10:92D
15. Infant Formula, Ready to Feed - AB-16-1:93
16. Spices - AB-14-12:95
17. Soy Sauce - AB-14-03:94
18. Worcestershire Sauce - AB-14-04:94

Application for inclusion on the above enumerated Acceptable Brand Lists for foods shall be made in writing and addressed to: Purchase Director, Food Unit, Department of Citywide Administrative Services, Division of Municipal Supply Services, 1 Centre Street, 18th Floor, New York, NY 10007. (212) 669-4207.

j4-jy17

#### EQUIPMENT FOR DEPARTMENT OF SANITATION

In accordance with PPB Rules, Section 2.05(c)(3), an acceptable brands list will be established for the following equipment for the Department of Sanitation:

- A. Collection Truck Bodies
- B. Collection Truck Cab Chassis
- C. Major Component Parts (Engine, Transmission, etc.)

Applications for consideration of equipment products for inclusion on the acceptable brands list are available from: Vendor Relations, Department of Citywide Administrative Services, Division of Municipal Supply Services, 1 Centre Street, 18th Floor, New York, NY 10007. (212) 669-8562.

j4-jy17

**OPEN SPACE FURNITURE SYSTEMS - CITYWIDE** – In accordance with PPB Rules, Section 2.05(c)(3), an Acceptable Brands List, #AB-17W-1:99, has been established for open space furniture systems.

Application for consideration of product for inclusion on this acceptable brands list shall be made in writing and addressed to: Vendor Relations, Department of Citywide Administrative Services, Division of Municipal Supply Services, 1 Centre Street, 18th Floor, New York, NY 10007, (212) 669-8562.

j4-jy17

### ENVIRONMENTAL PROTECTION

#### ■ SOLICITATIONS

##### Services (Other Than Human Services)

**CONTRACT OPERATIONS OF THE CROTON WATER TREATMENT PLANT** – Request for Qualifications – PIN# 82610CRTNOPS – DUE 03-12-09 AT 3:00 P.M. – The New York City Department of Environmental Protection (DEP) is establishing a Pre-Qualified List (PQL) of Contract Operations Firms who will be allowed to compete for Contract Operations Services for the Croton Water Treatment Plant (WTP). The DEP intends to advertise for competitive proposals to those Contract Operations firms on the Pre-Qualified List. It is anticipated that the proposal will include the following services for the Croton WTP:  
1) Planning and management of a seamless transition from construction to contract operations including participation during Field Equipment Testing, Start-up Testing and Commissioning, and equipment/system training.

2) Operation of the Croton WTP once operations commences.

The Croton WTP is located in the Bronx, New York. The Croton WTP is currently under construction and is designed to treat 290 Million Gallons per Day (MGD). Once construction is complete in 2011, an average daily flow of about 140 MGD is expected to be delivered from the plant.

DEP anticipates contracting for services for Full-scale operation of the Croton WTP to a private company.

Neither the issuance of this SOQ nor the acceptance by the DEP of responses from qualified firms will be deemed to create an obligation to either execute a contract or select a vendor directly from those responding to this solicitation of information.

The City is not responsible for costs incurred in the preparation of any documents related to this solicitation.

The Agency reserves the right to postpone or cancel this SOQ, in whole or in part, and to reject all proposals.

A non mandatory pre-solicitation workshop will take place on Thursday, Feb. 5, 2009 at 10:00 A.M. at the Croton Treatment Plant. Please see attached document for all information.

Use the following address unless otherwise specified in notice, to secure, examine or submit bid/proposal documents, vendor pre-qualification and other forms; specifications/blueprints; other information; and for opening and reading of bids at date and time specified above.

Department of Environmental Protection  
3701 Jerome Avenue, Bronx, NY 10467.  
Michael Keating (646) 438-0759, mkeating@dep.nyc.gov

☛ j15

**FINANCIAL INFORMATION SERVICES AGENCY**

**CONTRACTS UNIT**

■ INTENT TO AWARD

*Services (Other Than Human Services)*

**SOFTWARE MAINTENANCE AGREEMENT** – Sole Source – Available only from a single source - PIN# 12709C002002 – DUE 01-16-09 AT 10:00 A.M. Software Maintenance Agreement with Chicago Soft, Ltd. 6232 N. Pulaski Road, Chicago, IL 60646-5131. Software is proprietary to the vendor. Any other vendor that can provide this software maintenance is encouraged to reply to this notice on intent to award.

Use the following address unless otherwise specified in notice, to secure, examine or submit bid/proposal documents, vendor pre-qualification and other forms; specifications/blueprints; other information; and for opening and reading of bids at date and time specified above.

Financial Information Services Agency, 450 West 33rd Street, 4th Floor, New York, NY 10001-2603.  
Robert Aboulafia (212) 857-1516, raboulafia@fisa.nyc.gov

j9-15

**FIRE**

■ AWARDS

*Services (Other Than Human Services)*

**HVAC SYSTEMS CLEANING SERVICES AND DUCT WORK MAINTENANCE** – Competitive Sealed Bids – PIN# 057090000298 – AMT: \$310,500.00 – TO: Indoor Air Technologies Inc., 33 West Main Street, Victor, NY 14564. Cleaning, vacuuming, washing and sanitizing heating, ventilation and air conditioning units and associated ductwork, and performing incidental ductwork maintenance, at Fire Department facilities located throughout the five (5) boroughs. Vendor Source ID#: 54409.

● **PHARMACY BENEFIT MANAGEMENT SERVICES** – Competitive Sealed Proposals – Judgment required in evaluating proposals - PIN# 057070003075 – AMT: \$47,052,800.00 – TO: Express Scripts, Inc., 7 Campus Drive, Parsippany, NJ 07054. - Pharmacy Benefit Management and Prescription Drug Disbursement Services. Vendor Source ID#: 42746.

☛ j15

**HEALTH AND HOSPITALS CORPORATION**

The New York City Health and Hospitals Corporation is regularly soliciting bids for supplies and equipment at its Central Purchasing Offices, 346 Broadway, New York City, Room 516, for its Hospitals and Diagnostic and Treatment Centers. All interested parties are welcome to review the bids that are posted in Room 516 weekdays between 9:00 a.m. and 4:30 p.m. For information regarding bids and the bidding process, please call (212) 442-3863.

j1-d31

■ SOLICITATIONS

*Goods & Services*

**SERVICE CONTRACT FOR MAINTENANCE OF CAMERAS AND EXTERIOR LIGHTING** – Competitive Sealed Bids – PIN# 11209054 – DUE 01-28-09 AT 3:00 P.M. – In certain area throughout the Harlem Hospital Complex. There will be mandatory site visits on 1/21/09 and 1/22/09 at 10:00 A.M. (attend only 1 of the dates mentioned). Location: Harlem Hospital Center, Hospital Police Dept., Old Nurses Residence Building, Administrative Office, 506 Lenox Avenue, 1st Floor, Room #10, New York, NY 10037.

Use the following address unless otherwise specified in notice, to secure, examine or submit bid/proposal documents, vendor pre-qualification and other forms; specifications/blueprints; other information; and for opening and reading of bids at date and time specified above.

Lincoln Hospital Center, 234 E. 149th Street, Room 2A2 2nd Floor, Bronx, New York 10451.  
Giselle Rodriguez (718) 579-5087,  
giselle.rodriguez@nychhc.org

☛ j15

**HEALTH AND MENTAL HYGIENE**

■ INTENT TO AWARD

*Human/Client Service*

**PROVISION OF TREATMENT TO HIV ADULTS** – Government to Government – PIN# 08AE206100R0X00 – DUE 01-28-09 AT 4:00 P.M. – The Department intends to provide provisions of treatment care and supplemental services to HIV adults living in Westchester, Rockland and Putnam Counties.

Use the following address unless otherwise specified in notice, to secure, examine or submit bid/proposal documents, vendor pre-qualification and other forms; specifications/blueprints; other information; and for opening and reading of bids at date and time specified above.

Health and Mental Hygiene, 40 Worth Street, New York, NY 10013. Kermit Bostock (212) 442-9023,  
kbostock@health.nyc.gov

☛ j15-22

**AGENCY CHIEF CONTRACTING OFFICER**

■ SOLICITATIONS

*Human/Client Service*

**NEW YORK/NY III SUPPORTED HOUSING CONGREGATE** – Competitive Sealed Proposals – Judgment required in evaluating proposals - PIN# 81608P0076300R0X00 – DUE 02-13-09 AT 3:00 P.M. The Department is issuing a RFP to establish 3,000 units of citywide supportive housing in newly constructed or rehabilitated single-site buildings for various homeless populations pursuant to the New York III Supported Housing agreement. The subject RFP will be open-ended and proposals will be accepted on an on-going basis. Since February 16, 2007, the RFP has been available for pick up in person at the address listed below, between the hours of 10:00 A.M. and 4:00 P.M. on business days only. The RFP is also on line at <http://www.nyc.gov/html/doh/html/acco/accorfp-nynycongregate-20070117-form.shtml>. A pre-proposal conference was held on March 6, 2007 at 2:00 P.M. at 125 Worth Street, 2nd Floor Auditorium, New York, N.Y. Any questions regarding this RFP must be sent in writing in advance to Contracting Officer at the above address or fax to (212) 219-5865. All proposals must be hand delivered at the Agency Chief Contracting Officer, 93 Worth Street, Room 812, New York, NY 10013.

As a minimum qualification requirement for (1) the serious and persistent mentally ill populations, the proposer must be incorporated as a not-for-profit organization, and (2) for the young adult populations, the proposer must document site control and identify the source of the capital funding and being used to construct or renovate the building.

Use the following address unless otherwise specified in notice, to secure, examine or submit bid/proposal documents, vendor pre-qualification and other forms; specifications/blueprints; other information; and for opening and reading of bids at date and time specified above.

Health and Mental Hygiene, 93 Worth Street, Room 812 New York, NY 10013. Huguette Beauport (212) 219-5883  
hbeauport@health.nyc.gov

o15-f12

**HOMELESS SERVICES**

**OFFICE OF CONTRACTS AND PROCUREMENT**

■ SOLICITATIONS

*Human/Client Service*

**TRANSITIONAL RESIDENCES FOR HOMELESS/ DROP-IN CENTERS** – Competitive Sealed Proposals – Judgment required in evaluating proposals - PIN# 071-00S-003-262Z – DUE 06-25-10 AT 10:00 A.M. – The Department of Homeless Services is soliciting proposals from organizations interested in developing and operating transitional residences for homeless adults and families including the Neighborhood Based Cluster Residence and drop-in centers for adults. This is an open-ended solicitation; there is no due date for submission.

Use the following address unless otherwise specified in notice, to secure, examine or submit bid/proposal documents, vendor pre-qualification and other forms; specifications/blueprints; other information; and for opening and reading of bids at date and time specified above.

Department of Homeless Services, 33 Beaver Street, 13th Floor New York, NY 10004. Marta Zmoira (212) 361-0888,  
mzoita@dhs.nyc.gov

j12-24

**SAFE HAVEN OPEN-ENDED RFP** – Competitive Sealed Proposals – Judgment required in evaluating proposals - PIN# 071-08S-04-1164 – DUE 08-27-10 – The Department of Homeless Services has issued an Open Ended Request for Proposals (PIN 071-08S-04-1164) as of August 27, 2007 seeking appropriately qualified vendors to develop and operate a stand-alone Safe Haven for chronic street homeless single adults and/or adult couples without minor children.

There is no due date for proposals under this RFP. Proposals will be reviewed by the Department as they are received and contracts will be awarded on an on-going basis until the Department's needs are met.

Use the following address unless otherwise specified in notice, to secure, examine or submit bid/proposal documents, vendor pre-qualification and other forms; specifications/blueprints; other information; and for opening and reading of bids at date and time specified above.

Department of Homeless Services, 33 Beaver Street, 13th Floor New York, NY 10004. Suellen Schulman (212) 361-8400  
sschulma@dhs.nyc.gov

a27-f12

■ INTENT TO AWARD

*Human/Client Service*

**FURNISH-A-FUTURE** – Sole Source – Available only from a single source - PIN# 071-09S-03-1377 – DUE 02-02-09 AT 2:00 P.M. – The Department of Homeless Services (DHS) intends to negotiate a sole source contract with the Partnership for the Homeless (PFTH) to operate a Furnish-A-Future Program to provide families with start-up furniture donated by private companies and individuals.

The PFTH would serve as the oversight agency that coordinates the receipt, inventory and distribution of donated furniture to eligible families referred by DHS who are being placed from the shelter system into permanent housing, Citywide. The PFTH maintains a 29,000 square foot warehouse in Brooklyn for storing the in-kind donations. The current contract provides furnishing to 1,800 families per year.

It is anticipated that the sole source contract will be from July 1, 2009 to June 30, 2012, with a one-year option to renew.

Any qualified vendor(s) that believes they can provide these services to homeless families are encouraged to submit a written Expression of Interest (EOI) by Monday, February 2, 2009 to: Marta Zmoira, Contract Officer, Department of Homeless Services, 33 Beaver St., 13th Floor, NY, NY 10004.

Use the following address unless otherwise specified in notice, to secure, examine or submit bid/proposal documents, vendor pre-qualification and other forms; specifications/blueprints; other information; and for opening and reading of bids at date and time specified above.

Department of Homeless Services, 33 Beaver Street, 13th Floor New York, NY 10004. Bid Desk (212) 361-0888  
mzmoria@dhs.nyc.gov

☛ j15-22

**HOUSING AUTHORITY**

**PURCHASING DIVISION**

■ SOLICITATIONS

*Goods*

**GLOVES** – Competitive Sealed Bids – RFQ #6227 LD – DUE 02-03-09 AT 10:30 A.M.

Use the following address unless otherwise specified in notice, to secure, examine or submit bid/proposal documents, vendor pre-qualification and other forms; specifications/blueprints; other information; and for opening and reading of bids at date and time specified above.

Housing Authority, 23-02 49th Avenue, 5th Floor SCOD Long Island City, NY 11101. Bid documents available via internet ONLY:  
[http://www.nyc.gov/html/nycha/html/business/goods\\_materials.shtml](http://www.nyc.gov/html/nycha/html/business/goods_materials.shtml) Linda Darnell (718) 707-5438.

☛ j15

**PARKS AND RECREATION**

**REVENUE AND CONCESSIONS**

■ SOLICITATIONS

*Services (Other Than Human Services)*

**RENOVATION, OPERATION AND MAINTENANCE OF THE CAROUSEL AND SNACK BAR** – Competitive Sealed Proposals – Judgment required in evaluating proposals - PIN# Q15-B-CL, SB – DUE 02-18-09 AT 3:00 P.M. – In Forest Park, Queens.

Parks will hold a recommended bidder meeting on Wednesday, January 28, 2009 at 1:00 P.M. at the concession site, which is located at the Woodhaven Blvd. entrance to Forest Park. All interested parties are urged to attend.

TELECOMMUNICATION DEVICE FOR THE DEAF (TDD) 212-504-4115.

Use the following address unless otherwise specified in notice, to secure, examine or submit bid/proposal documents, vendor pre-qualification and other forms; specifications/blueprints; other information; and for opening and reading of bids at date and time specified above.

Parks and Recreation, The Arsenal-Central Park 830 Fifth Avenue, Room 407, New York, NY 10021.  
Evan George (212) 360-3495, evan.george@parks.nyc.gov

j5-16

**OPERATION OF A POOL MERCHANDISE CART** – Competitive Sealed Bids – PIN# Q4-SV – DUE 02-03-09 AT 3:00 P.M. – At the entrance to Astoria Pool in Astoria Park, Queens.

TELECOMMUNICATION DEVICE FOR THE DEAF (TDD) 212-504-4115.

Use the following address unless otherwise specified in notice, to secure, examine or submit bid/proposal documents, vendor pre-qualification and other forms; specifications/blueprints; other information; and for opening and reading of bids at date and time specified above.

Parks and Recreation, The Arsenal-Central Park 830 Fifth Avenue, Room 407, New York, NY 10021.  
Alexander Han (212) 360-1397, alexander.han@parks.nyc.gov

j5-16

**POLICE**

**CONTRACT ADMINISTRATION UNIT**

■ SOLICITATIONS

*Services (Other Than Human Services)*

**PLASTERING AND PAINTING** – Competitive Sealed Bids – PIN# 056090000624 – DUE 02-17-09 AT 11:00 A.M. – All labor and material necessary and required for the procurement of Plastering, Interior and Exterior Painting at the 5th, 47th, 61st, 90th and 94th Precinct Station Houses.

Mandatory Pre-Bid Conferences:  
Monday, January 26, 2009 at 10:30 A.M., 90th Precinct Station House, 211 Union Avenue, Brooklyn, New York 11211

Tuesday, January 27, 2009 at 10:30 A.M., 94th Precinct Station House, 1000 Mesereole Avenue, Brooklyn, New York 11222.

Wednesday, January 28, 2009 at 10:30 A.M., 47th Precinct Station House, 4111 Laconia Avenue, Bronx, New York 10466

Thursday, January 29, 2009 at 10:30 A.M., 5th Precinct Station House, 19 Elizabeth Street, New York, New York 10013.

Friday, January 30, 2009 at 10:30 A.M., 61st Precinct Station House, 2575 Coney Island Avenue, Brooklyn, New York 11223.

VSID#: 75498.

Use the following address unless otherwise specified in notice, to secure, examine or submit bid/proposal documents, vendor pre-qualification and other forms; specifications/blueprints; other information; and for opening and reading of bids at date and time specified above. Police Department, 51 Chambers Street, Room 310, New York, New York 10007. Stephanie Gallop (646) 610-5225. NYPD Contract Administration Unit, 51 Chambers Street, Room 310, New York, New York 10007.

j15

SCHOOL CONSTRUCTION AUTHORITY

CONTRACT ADMINISTRATION

SOLICITATIONS

Construction / Construction Services

ELEVATORS - Competitive Sealed Bids - PIN# SCA09-12095D-1 - DUE 01-30-09 AT 10:00 A.M. Bushwick HS (Brooklyn). Project Range: \$1,860,000.00 to \$1,964,000.00. Non-refundable bid document charge: \$100.00, certified check or money order only. Make payable to the New York City School Construction Authority. Bidders must be pre-qualified by the SCA.

Use the following address unless otherwise specified in notice, to secure, examine or submit bid/proposal documents, vendor pre-qualification and other forms; specifications/blueprints; other information; and for opening and reading of bids at date and time specified above. School Construction Authority, Plans Room Window Room #1046, 30-30 Thomson Avenue, 1st Floor Long Island City, New York 11101, (718) 752-5849.

j12-16

FLOOD ELIMINATION - Competitive Sealed Bids - PIN# SCA09-12187D-1 - DUE 02-03-09 AT 10:30 A.M. Robeson High School (Brooklyn). Project Range: \$1,550,000.00 to \$1,631,000.00. Non-refundable bid document charge: \$100.00, certified check or money order only. Make payable to the New York City School Construction Authority. Bidders must be pre-qualified by the SCA.

Use the following address unless otherwise specified in notice, to secure, examine or submit bid/proposal documents, vendor pre-qualification and other forms; specifications/blueprints; other information; and for opening and reading of bids at date and time specified above.

School Construction Authority, Plans Room Window Room #1046, 30-30 Thomson Avenue, 1st Floor Long Island City, New York 11101, (718) 752-5852.

j15-22

FLOOD ELIMINATION/CLIMATE CONTROL - Competitive Sealed Bids - PIN# SCA09-004443-1 - DUE 02-03-09 AT 11:00 A.M. - PS 157 (Bronx). Project Range: \$1,320,000.00 to \$1,391,000.00. Non-refundable bid document charge: \$100.00, certified check or money order only. Make payable to the New York City School Construction Authority. Bidders must be pre-qualified by the SCA.

Use the following address unless otherwise specified in notice, to secure, examine or submit bid/proposal documents, vendor pre-qualification and other forms; specifications/blueprints; other information; and for opening and reading of bids at date and time specified above. School Construction Authority, Plans Room Window Room #1046, 30-30 Thomson Avenue, 1st Floor Long Island City, New York 11101, (718) 752-5854.

j15-22

HVAC SYSTEM UPGRADE/SMOKE PURGE - Competitive Sealed Bids - PIN# SCA09-08950D-3 - DUE 02-02-09 AT 10:00 A.M. - PS 279 (Bronx). Project Range: \$2,430,000.00 to \$2,562,000.00. Non-refundable bid document charge: \$100.00, certified check or money order only. Make payable to the New York City School Construction Authority. Bidders must be pre-qualified by the SCA.

Use the following address unless otherwise specified in notice, to secure, examine or submit bid/proposal documents, vendor pre-qualification and other forms; specifications/blueprints; other information; and for opening and reading of bids at date and time specified above. School Construction Authority, Plans Room Window Room #1046, 30-30 Thomson Avenue, 1st Floor Long Island City, New York 11101, (718) 752-5849.

j13-20

TRANSPORTATION

ADMINISTRATION

SOLICITATIONS

Services (Other Than Human Services)

BID EXTENSION: MODULAR STEEL BUILDING UNDER WILLIAMSBURG BRIDGE - Competitive Sealed Bids - PIN# 84109MNAD362 - DUE 01-23-09 AT 11:00 A.M. - BID EXTENSION: Contract documents available during the hours of 9:00 A.M. - 3:00 P.M. ONLY. Purchase and Installation of Two (2) Modular Steel Buildings under the Williamsburg Bridge for Manhattan Street Maintenance and Bridge Preventative Relocation. A deposit of \$50.00 in the form of a certified check or money order made payable to New York City Department of Transportation is required to obtain

Contract Bid/Proposal Documents. NO CASH ACCEPTED. Refund will be made only for Contract Bid/Proposal Documents that are returned in its original condition within 10 days after bid opening. Any persons delivering bid documents must enter the building through 220 Church Street, New York, NY. Due to increased building security bidders should allow extra time and ensure that proper photo identification is available upon request. Please ensure that your company's address, telephone and fax numbers are submitted by your company (or messenger service) when picking up contract documents. For additional information please contact Robert Grant at (212) 513-0315. Vendor Source ID#: 57056.

Use the following address unless otherwise specified in notice, to secure, examine or submit bid/proposal documents, vendor pre-qualification and other forms; specifications/blueprints; other information; and for opening and reading of bids at date and time specified above. Department of Transportation, Contract Unit, Office of the Agency Chief Contracting Officer, 40 Worth Street Room 824A, New York, NY 10013. Bid Window (212) 442-7565.

j15

SPECIAL MATERIALS

COMPROLLER

NOTICE

NOTICE OF ADVANCE PAYMENT OF AWARDS PURSUANT TO THE STATUTES IN SUCH cases made and provided, notice is hereby given that the Comptroller of the City of New York, will be ready to pay, at 1 Centre Street, Rm. 629, New York, NY 10007 on January 28, 2009, to the person or persons legally entitled an amount as certified to the Comptroller by the Corporation Counsel on damage parcels, as follows:

Table with 3 columns: Damage Parcel No., Block, Lot. Rows include parcels 4, 4A and 4B; 8, 8A and 8B.

acquired in the proceeding, entitled: Victory Boulevard and Travis Avenue subject to any liens and encumbrances of record on such property. The amount advanced shall cease to bear interest on the specified date above.

William C. Thompson, Jr. Comptroller

j13-28

CONFLICTS OF INTEREST BOARD

NOTICE

The following serves as a confirmation of the receipt of filing of the 2007 Financial Disclosure Report for all filers who submitted reports on or prior to December 1, 2008. To find your entry, first look up your agency code (for example, "002" for the Mayor's Office). Then look up your login number (your EIN or unique identifier that you used to access the electronic filing program). Next to your login number, the date of your filing will appear, as well as the "hash" number, a unique sequence of 64 characters and numbers that serves as an electronic fingerprint for your particular filing as it existed at the time that it was submitted.

We urge each filer to make a copy of the published confirmation for his or her records.

If you filed after December 1, 2008, confirmation will be published in the "City Record" at a later date. Publication of these receipts also appears on the Conflicts of Interest Board's website: www.nyc.gov/ethics.

Table with 4 columns: FILER EIN, AGENCY CODE, FILING DATE, HASHED VALUE. Lists various filers and their filing details.

Table with 4 columns: FILER EIN, AGENCY CODE, FILING DATE, HASHED VALUE. Lists various filers and their filing details.

FILER EIN	AGENCY CODE	FILING DATE	HASHED VALUE	FILER EIN	AGENCY CODE	FILING DATE	HASHED VALUE
NYCHAB8193	996	08/25/2008	F3AA6213F00DED0F15BFF57C2933763E8B85C91F4704E5505C509444FAA3E9AF	NYCHAD19953	996	08/19/2008	24DD8705A7B857080AC3884239CDCC5C2D22FE8AF86AB6D556019D94D864EA3
NYCHAB8316	996	08/12/2008	D2F84ACAD65EDE97344779CE00DC094CD383D406C2ECC7FC412FD151CB698F7	NYCHAE0414	996	07/22/2008	8EA885D3019DB3688597FE15D18703E681BF3500A71486E4CD4386FEE5472C0
NYCHAB8352	996	08/14/2008	5E9D5E667141365048360B030ECB65BCF3C40240A4AA637C50CD90C7B0D85B	NYCHAE0521	996	07/15/2008	56446A7C5A0FDE3A1899653CA159CBDE7AA7D5448A1CC2B8C50559A56FC02B
NYCHAB8450	996	08/06/2008	9569402B46725F322BDD092DC1BC5EEE4899966506F7B7A1370458693B28AA48	NYCHAE0999	996	08/13/2008	98A2AEEF47981C0191FD16099497AE1629E3A54618AB4A2340A26B055B9CA92
NYCHAB8657	996	08/27/2008	8544C75B4D1880D9B5B2B7B4065D1C70874E5A3C57D57D7E0448B9F327122B05	NYCHAE3379	996	08/10/2008	562909F6BC090884B1BD1FDDE836F878BC11637D754A0F6DC5539FA142C86E08
NYCHAB8720	996	08/01/2008	F2C7DC4CC65146CE7FC6663EE9801EC83F68754F44F6504F3B4AB87C60A31AB4	NYCHAE4795	996	07/28/2008	6876502E0C6E1D00EF73227AE12A0A20B3E14C85EA98FE424CC92AD586D01EC
NYCHAB9028	996	07/24/2008	EC8125EB839089F9B14103542B09BCAF7581E68EE1C6BA9DFE3F6082C53BC71D	NYCHAE5785	996	08/18/2008	5C60A063601ADE82EFAED01C23DAE7C9444B03C933030C6BC8FB4F2031EB3A6
NYCHAB9438	996	08/27/2008	94A0492D74270558418DBEE5F3FF22BCFE55459405689E9570955877BD88218AC	NYCHAE7560	996	08/24/2008	C28DCB2B3E3C13D95E2FA0F9153A85D45A22A30DAE90D45F5E3D1BB9EAF2F3AC
NYCHAB9448	996	08/27/2008	6537B14766D9903132E4245B0003B6AF6AFDBE02229C54A656F995678070EE179	NYCHAE7902	996	08/21/2008	FBD39F177F067A9A2472B11567B9DFBFE27E71A8913EE697D1D6820E553718E
NYCHAB9652	996	08/29/2008	18C54E2BCD01371581500767F752AE2F8420D7141C2B9E5F7B230055069FB1D67	NYCHAE7931	996	08/16/2008	D34B00C1DB53C477AF45195E0B341F65F03518AEC9A9C7982435F719A929A47
NYCHAB9915	996	08/28/2008	602C4B63484FA37C89CF563BB98D3CC07B01CBB6154E5AC24452D0BB4123F	NYCHAE9304	996	08/06/2008	1842DCCA854ACC9F9E9518305FBOA7E4CCBAC54CE7F5B8497D967C7376669
NYCHABA3199	996	08/28/2008	8B238BBE7923F2520278EF4CD3486EFC4D636F933DCD1D92BE7D0F9B7BF2E0F2	NYCHAE9670	996	08/05/2008	CC764C4EA4C9E1735297EFAA166C19424C0A801AB13B0C922FB71E948FD4F810
NYCHABL9544	996	08/28/2008	FE29E9FF698C5DDFA2EE3F87B5879145A622F719D3E32A7F45E6EDD54F14A0A14	NYCHAF0083	996	08/22/2008	2ECADA098A04F6A684A0A392397F3E1162567A2D12F15D95791AD36ADE71F37
NYCHABR1691	996	08/22/2008	6B66FBE1853359404BD7A367202F88E89217D6A11A2B9E9E161F7439A5425A2E	NYCHAF0404	996	08/14/2008	62835C3C35739BAD9C1D3E9F8AA752E3A23011E5C77907F7BDAA6F5E183B47DA
NYCHAC0156	996	08/20/2008	847F61741876EF3AE4153AC08B1763CAD518CAD237A29C77C759A743A312DA13	NYCHAF0580	996	08/12/2008	90A5315FE7D7BBOA863FF3FE5E2ED833534C7F2EBFC173F19EA7980F215DA4B
NYCHAC0332	996	07/23/2008	E5BE0BF8CFF61BC6B46EDBDC65B75CAF8C033FAE946134C62210101559E4F4A20	NYCHAF0714	996	08/04/2008	428CEACDA97E6FF8BE6C9A9F6AEB03AA2BF0ECB6A8D77D52CA8BE8E20257F9F
NYCHAC0853	996	07/29/2008	09E7FBEBC7CF9A458C43136E7844BD1EC16FEF8F325F9E6177D879B124F3B1C	NYCHAF1560	996	07/22/2008	45A75B37508A39A3CAF51F97F45FD6D031C59F805AFF41F7507E4E065C467B
NYCHAC1190	996	08/15/2008	6D29E8DB8936409FE59626FA138E88B907ABE655CCE0AE6717783F36E5C5B3C2	NYCHAF1604	996	08/25/2008	3EA99B9A5ED50E3F0BE49541F5F145FD1D31E9F8D031C59F805AFF41F7507E4E065C467B
NYCHAC1381	996	08/26/2008	93C393C6A0338D27F4F84CD25E279B757ECB7FA9F53DEF0C3652CFB45F7CA9B9	NYCHAF1816	996	08/05/2008	8FC227F5D5E0F43E35923804527517043B97E317DAECC3E362016C664437E8
NYCHAC1629	996	08/25/2008	1E212FB73AC48D40E584AC683C735C0139AF82359B3EC01028B1B78123D53932	NYCHAF2004	996	08/22/2008	29219CF08106A7D273A5EA05B2DF1ABCDD05A587C31D0193C0A79CE570726A1
NYCHAC1956	996	08/12/2008	E65A8688EB40541B777277A56999871E288B0FA973A551D72523752B37FB9C88	NYCHAF3121	996	07/27/2008	B371A299A73047AC3DC12CE5601651D7E5AB23FECC277E4F4942F34ACDF40A88
NYCHAC2078	996	08/29/2008	CE90CDBAC6752159AD9E3B9DA9A5E6DA69168FC52421D3EDF300B0EBD3D23360	NYCHAF4191	996	08/18/2008	A863BD9C88E40255B67B0BF830C1A2E383C271195C323C3D27A597CF841D59A
NYCHAC2509	996	08/19/2008	83A696696963EA9D64497B99F63A68595253542FC1CD948977C55B6E8534697	NYCHAF4474	996	08/28/2008	71CB760D39C2545D922542369225B2B665D300748A681AA17AD07CAF05BE653
NYCHAC2598	996	08/03/2008	5A3E556B09B29C445644B9A00DF7B5F32A11B97F749110970E1AF965C19F4DD1	NYCHAF4615	996	07/22/2008	94E2A08F4F75548997531160B18C04C299E4F80582F3BFC1B250A5405E4C66C0
NYCHAC2626	996	08/27/2008	2175AC41F749B57FABE580AF83DF92D1021E4270089A4A1DD34E22FE3522330	NYCHAF5419	996	08/05/2008	509542014B165B3880141AEDF26178986981B9CFD6910CF364F052041433C318
NYCHAC2731	996	07/29/2008	EAD030797894CB42DE84A5F696508E6BD2091AF275DA0A02926F54834077CCF	NYCHAF6005	996	08/19/2008	0F581603C3A9C82EDB4E92CB8E0A15DE699E1404C109DB50DBC2DAAAAC510
NYCHAC2833	996	08/26/2008	6532775116F77A1BA9B1EA99226713F67F86C1D1D61E1CFC248C1D8CE8718BE	NYCHAF6636	996	07/29/2008	EAE4FDE181364D8589C2B8F9784EDCD35A33DC102B36107357756AD91784BA8
NYCHAC3443	996	08/07/2008	1A3220E1832B700FD5C054E0A75F0640729F165AF65E5FADCC823AE26CE6D2	NYCHAF7385	996	08/28/2008	9A42FAD8AB289A9AD234575DB7D97D258F6F7155FE7F33F8D08EC2CD1F6B24
NYCHAC3478	996	08/22/2008	7F8DF88D3B4CF9E5B0CA82F4C007160320B29C40AAB6BD402EAB6431AC4A50E5	NYCHAF7522	996	08/25/2008	AD51E6DAEF99E0A1EAE344CAEDCFB90C6EFA78DA6A5FFE9A11416B354DOC365
NYCHAC3765	996	07/29/2008	9B04CA706EBEAE6EFC9D5910ED6DA69325E9ADA894375F79A48BA64280E27C	NYCHAF7999	996	08/29/2008	C5303D0FB26C387F9295320D6E57F1B324438948019857CB306130EA7822768
NYCHAC3793	996	07/29/2008	768AF42B4DEB047C759B33715801DB70E9676955BACE1676F4977924D0D8F0B4	NYCHAF8824	996	08/25/2008	05F464C643B8E01B78F48024E45A7D82992281A4E70D60F16B3DA8FB8810E3
NYCHAC4107	996	07/29/2008	2614C440A9A40E5D2A928B99A9E365C5252472D3F85411F1B499BA693B18D590	NYCHAF8872	996	08/04/2008	F99602FB2F1E9B88D8ED6AAF2A20763B1B6DD0D5CC847BF55B44022AD130
NYCHAC4165	996	07/28/2008	F9B3F3B4691BAA43C106F169AD8E8B88BB30BEFC71A12093A03C13B3F3	NYCHAG0076	996	07/30/2008	3B31DC3B096460E72992A3B4AD4FCFC87B30341B2A006B78A85A60FA5E5879
NYCHAC4343	996	08/26/2008	D44FA471D9D3AD13CB4F28F8074D1178AE335E12AC9A1C08C73BF43872FB9E	NYCHAG0159	996	07/30/2008	09BF6C2435F291C8CF9ADD46D6D01E5F98DF92F51A2605A67E4F4AB2D2517E
NYCHAC4422	996	08/27/2008	F4D0421B336C4839BD5069A4868C592907C96173CE56348D0F20A1AED9B64931	NYCHAG0424	996	08/21/2008	DCA10436E9650713F055D4B081A63D8F35582C09114950697E1DFDD0C77A5FF7
NYCHAC4509	996	08/03/2008	FD3FCB223860EFAAE838A5F4372BA0F933B136A842A0426437ED4E2173457FD7	NYCHAG1203	996	08/20/2008	21AE5340F57629C1695830130DD0FE54049A467D01E78097CF522CD569A048C2
NYCHAC4660	996	08/29/2008	83B9B95EF002F4F7FEBA6C5DD871B5DBBE251860A639E3C5690911891829BEB	NYCHAG1624	996	08/28/2008	A4B4DF6165763774849A8593B2F24C3C2E68EA174C466A957E3B32F1E71B7E
NYCHAC4686	996	08/18/2008	838ADBF1DF901F0BF939C4BFA05681062B0084545A4F6C54644F31A17AEF75F	NYCHAG2075	996	08/28/2008	4183975BD19AFAC8066F1069F3D82FAC652ACC384252EDD487AA0F6F004DFB8
NYCHAC4829	996	08/26/2008	1D9C57EC859D6966CD6F9E382D55BDFCE3DC1862456884D1DA525C3DA5E7805F	NYCHAG2088	996	08/28/2008	0EFB7B8904F4535B82094640F56CAEFF23F7B534D562A77C284630C9A08F1D
NYCHAC5352	996	08/25/2008	6F7ADDBC5A7846A01AEC27863E0D9058920ACF023FA981ACD115AF6C87F4BBCA	NYCHAG2143	996	07/31/2008	308716F6A81A68D395735271443D8250C41C4295D48CB4E48DB533A47938DE
NYCHAC5793	996	08/26/2008	32983FE4EBDDDFB4FC703BF8E9472B7D602657478095A604A999A8F8A578596C	NYCHAG2490	996	07/30/2008	2952FA1BB1F6E7D0391B193C97E4D2CA4EAE3A5AC15C329C6A7F4C27692796
NYCHAC5905	996	07/23/2008	5A1FD9AD40621A0E8B505FD58B64F2D28704EE962F915AF3EBF8EC48E35C50F	NYCHAG2630	996	08/19/2008	5536916DBEE1EADB8907E78DF2E206509E19B8AD225C027481FC456D3F0DA
NYCHAC6182	996	07/27/2008	FA2BAEC2869E86403607C039539420522F89479D6F88E5F6B8B64B52C16A76D	NYCHAG2783	996	08/28/2008	9C1F3C4CE99F50B033563E2CE3855AB53A4204F6691B3D70659BF337D6A9A9BB
NYCHAC6193	996	08/20/2008	C7F4EFA1655BAAD51D553A57535D7FBF424D11F2A6CEB499FA169F792C1A2C28	NYCHAG2848	996	08/27/2008	693E1F804E6B8FC5B43C434573D332BD0B1C785B8EF39D3D1C5F28DCFA6ADE76
NYCHAC6248	996	08/18/2008	CD2D911C7208DA9882BA7737339BFCA7C01EEB91D118FFD7985DB6A7F2F11D3	NYCHAG3267	996	08/04/2008	74C8E75A4A97DCF610C30B71D1B06F92A1F235A71146CB93363BE0A0CBB79601
NYCHAC6457	996	08/21/2008	311621CEF2A3860D05BB3BC989B0D05CF8F64D4B4F48208E27DAB508D38366C0	NYCHAG3329	996	08/14/2008	72F02A112D7810A1F70E7C9A936D722BF90A637E5F5D7E6CFFF993F9BDF1F3
NYCHAC6511	996	08/15/2008	2CAF6D421CA7A9496F03CC47C14F450F32AED3214F87131E6F5CEE3A3D74CDB50	NYCHAG3505	996	08/12/2008	89FD9CCDE0880059ABC7E8EEF15572F973B3BDB8C8823F030C3254A9E5376B
NYCHAC6769	996	08/25/2008	41B34D56240A4E2E728EEOC2A02D73B136EA9A3E21803486628060EECA4D2C5	NYCHAG3692	996	08/22/2008	14DCDDA616ED987C6DC0AF661C7BFE9CF49D887621C77AE19FB93D24F5C9E14D5
NYCHAC7084	996	08/19/2008	3F1E907DFA81E650E630B8C06B8091E47DC12134D7B57622B6470955A835DE5C09	NYCHAG3973	996	08/28/2008	B4015A7131076CDD66C7FE58890E1263DEF4C14AD9D0267501713AF59C6E77E
NYCHAC7124	996	08/12/2008	CA5C2D6450BFF288E902038C18CB9D542DE80A2D0324ED4389C27155FC9ED39	NYCHAG4407	996	08/06/2008	FA22C49F48073AEEEA6621E3D6993879A9E9F41B4D95AB9D5A0E3FEF2F377E
NYCHAC7555	996	08/02/2008	6FE83677D656B5214DBAAF4C7932DFE12A76137ED23CDFE492D241DE4AFFE852	NYCHAG4443	996	08/12/2008	C672AD6259FC8B2625D32CC34EEA42E13E2A9D6C320F96D97D1A86DABECAF7
NYCHAC7674	996	08/26/2008	6FEFA9A80CA669F949BD0FE2CB6D1C88423957042A71F8A51CB8851BC9A0E2E	NYCHAG4453	996	08/27/2008	0F349343C9177C71D8BBAF8F334164E02CC7C10CF5932D31EC5ADC407C4C509A
NYCHAC7737	996	08/11/2008	C14F0EB8E1891CF0FD6B4B85720D668BBC1F9847438174730D95D546CD9D6F9C	NYCHAG4668	996	07/22/2008	42F054522CA1D6A18FC90EB840F986F0A14591EB9B5E5F5C71CEDCD5FF8A6E443
NYCHAC7879	996	08/27/2008	FDD65AF29E43244BEE34F08F605540EBFDE36366D5BA773AE87054607372CF1F	NYCHAG5245	996	07/29/2008	9A889974AC0A64B0EC5AE47D276B3D6C612BD2BA68449B2215ABD4AD6A47B1
NYCHAC8079	996	08/04/2008	DAB19E97162C760B7D92B7AA126CBE62F6FE7B96FC2857682C377048DEE3ADB	NYCHAG5561	996	08/18/2008	B39ABC917AD0448FD4310512ABCCE722D9BE461248353E6E2552991BA4D261F
NYCHAC8301	996	08/11/2008	6610349779D4569E761A5B2B3A4CC8505765A144C750E6B4759991941635D3B	NYCHAG5646	996	08/22/2008	4D8ACDD0C045F4DB68B7F2A0111BAB82793427643688157616A959F9BA3E1A
NYCHAC8303	996	08/25/2008	E2F9D4ACAF5EF80DA73A629CEE5DEBFA376E0FE6B4193CC00A693C9F749310	NYCHAG5653	996	08/11/2008	71E0958868F800B3ABC6C43171EED6957216BD1E811169592B39F1D407C292
NYCHAC8326	996	07/30/2008	73713ED4B10E43F53D8DF45F2A2D5E1BA8E4E68898A3F21D983266811A656D36	NYCHAG5783	996	08/15/2008	EABE5DE0D7B394C170D7769A62B5431C60EBA31D46D5BFD18073834B875081AF

FILER EIN	AGENCY CODE	FILING DATE	HASHED VALUE
NYCHAH6312	996	08/18/2008	C7E60D96E410C756AD1767D2DDFE756AB6741737C7A9F996B38550FE3F397
NYCHAH6325	996	09/09/2008	76A2A0F9B144DC7579A8CF2ED09813E40E9AD135222D90693C7DFD8FF6027467
NYCHAH6345	996	07/21/2008	71B1E61C581106D11A0AE16A136984396E125798C48E95060D1EAD3BD2644E
NYCHAH6548	996	08/28/2008	EEF3D4D9247B7815F97056A0BFBFD2BE45D47C8E6AF53BCC008D882349031D
NYCHAH6961	996	08/15/2008	20B97FE86F4088B510ACD02DC97AD2782021F2D992797CA25D7C51EE14ADEDB
NYCHAH7314	996	08/08/2008	A41A869B448D7CE8FD3D96E6E3E6895BF9DFDD0662E5ED1A60061B63555EE299
NYCHAH8634	996	08/21/2008	7E2AC33F6AE00D3E37D96ECD3FB47753629AF3C876FC242EF8DC208F845B982
NYCHAH8635	996	08/26/2008	C769589C096B81FF6CA98132D16D6BB5EAE29FE142BFD42F38CCA9FCFF4A2E0F
NYCHAH8712	996	08/28/2008	31E953F4E694CC102C1EA2727869A8A446FCFAF095534B62B843F488646482A6
NYCHAH8922	996	08/14/2008	2F3E5F2B43D4CDF22EF241B97ED1813FC4FB197E8BC3DE66CFDE8CA3B7F203CC4
NYCHAH9173	996	07/25/2008	CF4C72FF154BF984B692945CFD18CB6BE94D293CDD63AB6E6FB9A58C4F344F0
NYCHAH9511	996	08/29/2008	34DF92B806D2B155807CB983C5B82EDBCF689F8FB4028849E8D68363190A2502
NYCHAH9700	996	07/30/2008	E2DDB3FCB06D1001C9975848BD7B7F0BCCBA9BE7875CFE81503D1ACF28FEB9D6
NYCHAH9708	996	08/25/2008	E0F1C0DDF64DF3823DF77C390DAF827BA04CE3ECFE3B658BC747B502B364304
NYCHAI2986	996	07/23/2008	C8629E2C58F05F1B69116E6495FA1D711CE27F25C68DA90E00F936881599DEB
NYCHAI6976	996	08/12/2008	D9E0E40CA904DD3524A0BDECF1F29A2A1F005CC2C6D77F0604117C0C22C
NYCHAI7562	996	08/04/2008	2445E558F25F13553A5C3990B58C8A8B2403E3BDE74F72ED7929DA4199A0B9F
NYCHAI9411	996	07/25/2008	081B80810DF91D5116D032FB2B619D5F81723671AF691C3F3155B41D8FDEE5061
NYCHAJ0869	996	07/31/2008	048C43985D9E71C5832D0ECB9BDE31EDA4A06EA46A1B0F3F267850B83813BE6D
NYCHAJ2412	996	07/31/2008	B53ED5B78B4BC17C45EACC7520922EB25822B04BF9C608471E494649F1D3BD6D
NYCHAJ3024	996	08/25/2008	B642E9C2AA2B985DFCCB7E2EDD3D5D20948737D1BED2E2F71B8F8F77657D3
NYCHAJ4450	996	08/13/2008	15051F2401282142ED630CFDC59B8B5D89D51984414E7B4377A12422AC2F71B8
NYCHAJ4481	996	08/12/2008	6B13E72894EC80E12FCB5C9F497E0C06A30566C36F1737B34E791EC0BE18A3
NYCHAJ4580	996	08/29/2008	9EE561C28C0A2AE295E6F8288598C500EBDD19D4EF463B1118A207E7EA415C72
NYCHAJ4598	996	09/10/2008	414A8569790F59406FB905B4B992D4C0FBD9A7EDB888A7FF01A7AC8583798B
NYCHAJ5600	996	08/04/2008	9586EE4D79ABA5B46A2BCEDEBAE40AF81723671AF691C3F3155B41D8FDEE5061
NYCHAJ5942	996	08/19/2008	1636B607D7D7F037A4C15ACA447CDA63482F691644EF72375AA13E3020B57B
NYCHAJ6344	996	08/20/2008	EBC94EAC62AFFAD47933E2214530226327F799F30CA982E94CEA2F3AFE579763
NYCHAJ6385	996	08/25/2008	DD336C0B768F71D39AB6C5DEAB4BC29DCDEE9E87F6F690FC753D51B69D7C5C4E7
NYCHAJ6735	996	07/21/2008	381261B2C25892B0286D46D74E9D4F695FBC59991B0F1E8DA1098D4326132FF
NYCHAJ6914	996	08/27/2008	696DB16C332CE168B2C268EFC5D5F798CA1EDED2FBC789162FD2F18DDE858F20
NYCHAJ7415	996	08/28/2008	34A6F3B8248095D810A44CCF2A1FAAE550282F8C546485B17972FBB2E7EA3C9
NYCHAJ7617	996	08/21/2008	102F514DB43BC67048391EE624E5645ECA132B8CA40833D445C002A52CC265C
NYCHAJ7857	996	08/27/2008	B4329E79DB99E2B09BD1A49F4CB8844DF478CEA0CA452D7260B6964F1D5F2FF
NYCHAJ7946	996	08/29/2008	E056A95CBC2E2E610C05C04FCA16C415A02E694576341A62A92B1D7178CAF77
NYCHAJ8030	996	08/11/2008	01D5F1DC9AEAFBD09CB87300D6214EFC278F51BCE8F8281760F38305533862D
NYCHAJ8164	996	08/27/2008	C32817BD2EF8D2C38A16DA6051EA92FFD22861A8FFD507471895D7ED9504FF
NYCHAJ9253	996	08/03/2008	E983A5E46FC02904DD6C897EBF48AD489C0D9A698A4624C21CFAD677C69D3FA9
NYCHAJ9286	996	08/29/2008	5013A478D8992A4B6C756E3E3D4FF7A7191EF4C100A6880504D76DDC47C0F983
NYCHAJ9426	996	08/22/2008	41F9B6F9930A6FCB40B185A4AF2D31337067B26C07F68F201BB9A3FC21907F7D
NYCHAK0052	996	08/26/2008	D6C767C63489B6EDD505A914C12285CA20303725E6B221F60E031C5A511B7F
NYCHAK0699	996	08/19/2008	43367658A711742FC85D0A8F70E26022307D18DEB7E015671656E356E7984C9
NYCHAK1906	996	08/30/2008	B9C76D1D67169F8E3BA7CCB172481BDBB97AB524D1B37EAB33C92B079E2D137
NYCHAK2141	996	08/24/2008	89B69ED3D7EDF3AFF7684FAEE9D7B4C1830E1B13D1293B354CF239CFE52482F7
NYCHAK3113	996	08/24/2008	BF22D762AB73660B3BEA963DC1E12FFE5E2A7120A34217CD7B86E63497127DA
NYCHAK3313	996	08/05/2008	927E534D52F2D41B883CE9AD899E3181D055CECEA233E27C8F0A0D092EBA3923
NYCHAK3447	996	08/25/2008	5219E4848CBCAB6240FC808FD60BA4C2213E2499A5D1F66A66A28D875A5C04FC
NYCHAK3946	996	08/13/2008	B940BAF1756D8D7BEE16B63B8C24A15E3E83A40FE8A1D83D1ED3E6639C3523C52
NYCHAK4011	996	08/28/2008	B81B4B9AB0776D4B0D8420B326DD25A0770FESADLE46F45706B544A469536A24
NYCHAK4716	996	08/26/2008	9419DB9166A00B740AC3CAB34783E0F27CDD643567235A483B5E143E21B437D
NYCHAK4989	996	08/18/2008	86D7157EBA271BF6927650EEA8F7857BA10D890C40FAD53B98F2E4AFC18D29BF
NYCHAK5089	996	07/23/2008	29FED443C0EA89FC96EBD047B6DA9895B7B29A73D9F8195842F8E9008F6A0D7E
NYCHAK5280	996	08/13/2008	27E67C1126C1D13456F377FA38C6C8751154286BA66610F1781B72204467C216
NYCHAK5425	996	08/29/2008	F43FDC4F88DDE77AC2B994AB32D49310AAD593740A4048E832C56B839BBE23FA
NYCHAK6056	996	08/07/2008	A201191523C927A910B24E700B3E3C118547441B7F04A77CE42B1B004018FA4B2
NYCHAK6144	996	08/28/2008	225A9F4DDB64D36BA9DAF34D20B951B3CE54B154C749483A557DF460471491B59
NYCHAK7075	996	08/17/2008	01E34A9BDB0E9DE7C2BB557AFF2CE8B444A76965336A24D3BC9D055F8240A987A
NYCHAK7109	996	08/28/2008	2F53484BE577C5CB09D531E807639564B73E3E4C365AC2147C6B923BD012F99
NYCHAK7520	996	08/27/2008	3EF2CE55B0EF73BC4F3754B82F10206B672FE97BDD8CC92D975A9A01CD163F
NYCHAK7945	996	08/27/2008	5D341DA95F6DE2F1DE7DDCA262DC38EE1EDF083B767F63B2ADF419059141AB
NYCHAK9620	996	08/22/2008	BCDACACD0513F7842F41C505FDC4ABD26331B7D0E8161E0C0F73834A8324435
NYCHAKA6172	996	08/17/2008	26AD15E770A1355BAC88A6D1F54842C9C0443BAC266A17B94886559599ABA2BA
NYCHAKA7770	996	07/23/2008	D661C499154A7E881D3A1A3CACBDAAD5B480EEB4FE0D45413A9C000FA5C23A0
NYCHAKU4688	996	08/14/2008	6BF05DF57237B9EA5911E49B3BD604BCF1D4A6B9CF8D9E619933369D9851B3A
NYCHAL0035	996	07/22/2008	C08A684CEF3D1B22E1AB7F56113E7A0730A7FC9E87DDC48AD44D0A103B37AE
NYCHAL0105	996	07/31/2008	1ACDA4C826A08E90579BD7831B337CF00400FD28D5955E242A0A6D8AD22593
NYCHAL0193	996	08/29/2008	DF906FD824E20ACB795F8D6ACE9540CBA67C33BCBFCF7A50E786F34696FB86F5
NYCHAL0249	996	08/14/2008	B1ECF7DE607965CBD22A3A722ABB5A7E17DAD15257A5D80013C94CF65212E15B
NYCHAL0268	996	08/14/2008	5AED6FC560E9A8E7184005A7BA71E4B06DESEB0E8F504595892B1E43C8A90B7
NYCHAL0292	996	08/21/2008	0D187AA7FF4D9293C2BF73D92BAB5F8C3E207C706B845B1FAFAB2381A8BE66F3
NYCHAL0939	996	07/22/2008	109E5CA8A32B4856C06B2F2D9B273C1646C44D77EDD28B44E40FC46E4BFC0E0ED
NYCHAL1122	996	07/31/2008	C47957071533478955D7DD262A594C872F7B5A0590448DE5A28B71E2A10B2B3
NYCHAL1677	996	08/28/2008	00F12313BC54F430A8EBA420701617FC911FCC04CDE27E0D4D69E7891C17237E0
NYCHAL1887	996	07/30/2008	7F86A35EA983519DF8418F9BC77D7B451B2A32B37FDF23092EBC307251563F6
NYCHAL1903	996	08/22/2008	C39477F7CFC71A45BD9B2A15CE7B25A40BE9744FF6B58AC23E5795DFD145D983
NYCHAL2050	996	07/25/2008	A6D22EFD715BF51FDC621F1FCEA3595E03EE6BCB1A19AF8FB3F929FADEBFAFB
NYCHAL2590	996	08/08/2008	9ECA58B1989F8033AFA43E62DD68D2F28B640F1821BAC1422B3B9191F6DC7EE
NYCHAL2812	996	08/25/2008	82FA95E07F4C543C15490C3B489AC20940E440AB82DD45360A9FF5C4FD22F627
NYCHAL3082	996	07/27/2008	1952F3FC9E2C8292C6ABA2CC9924EF5E55BDF9A30ED0BA5019C2DA25D794E8
NYCHAL3511	996	09/09/2008	491F94F8B06FBBE4911EFDD55394737D997381A2A409B4486C191102D819C6FA
NYCHAL3656	996	08/27/2008	6358BC3BB09949BE5C2246715F078203B3F3086304543361399514919E941015
NYCHAL3698	996	08/29/2008	7BD2E80B702EF8091DBDB2C01513CAAD2A0274327F1D1C249B189A1C055FF645
NYCHAL3961	996	08/26/2008	223B3AC8AA1F064454533A2C2189AD6A75F94E2AF31F451B7238362A541BEAC9
NYCHAL4728	996	08/26/2008	27DC1A49CCE81B853A2FC286C9429051B1AC72B4E690A621DD929A6661D0128F
NYCHAL4783	996	08/05/2008	0FDFBEDB3973F40E5845D61D7AFD8EDB454B6F1253393FA7D8727A8DD230FCDD1
NYCHAL5330	996	08/28/2008	73A705D7EAFBFA6FE46D62DA3B608CF48E37A11F8533EE2A8F6AA56C2A0F2C22
NYCHAL5436	996	08/06/2008	2EE956BED95A1ADC27AC11B74B1E1F550800D51ADB7CE06EAC35FB15922A7ADB
NYCHAL5958	996	07/25/2008	83D1DCB603F65ADB00D3EAE5F36DAECE2C921A663236A98FA467C01B17974A
NYCHAL6127	996	08/21/2008	6F17A2B48AB55DB4A90C93F98A80F5D717188219A77BF5CF5D49914D822DEDED
NYCHAL6302	996	08/04/2008	AAB42BDEE1ECBAF45C327231EE578F494BC79470914ADD687AC0004697AC2F56
NYCHAL6442	996	08/26/2008	B4CAAFF9788A0852ED734A475F9EC9A90D39AFA2F571BC3B89C245F3DFBB079
NYCHAL7036	996	08/04/2008	DB4FBC939AF41BA5124E3A4B209AB8C364134FBCECF40AB71F96EF248709824
NYCHAL7403	996	08/27/2008	A85D16619D40F96E5E4C0722CCFC9A9054B3D40C14D8A7B40BD9BB9ED38DFE8
NYCHAL7940	996	08/27/2008	DDC3900E7C9EAA8CB42C38CE1B0C6BE8B5B9A5A0668E99C7E18934443AB3A79
NYCHAL8156	996	08/26/2008	AD7B877E88E5FA6AD78D4056C5749E776A6B3B8CE4AAAF41B154DC06745F864
NYCHAL8378	996	07/29/2008	3B4986DD4D8F21DA7D1D6441EBE0F82F3530343C91E31632D03BAAD906B394
NYCHAL8522	996	08/27/2008	1A1A8B8C4527E0FA6FAE1C7A1C9EADA4EF2841C07686903D3AE5A9EA0142129
NYCHAL9485	996	08/14/2008	E96BBBC0A505BB7B2BF71A0C533DBC302C496D1513D49B582F2934F641F5C32B
NYCHALI9186	996	07/26/2008	4568981EA71A984DF44FC57162C6DFCE415907DB5188EA65CC975E4739C16EEA
NYCHALO2869	996	08/29/2008	D1CA24E43A1E9E76C0BB7C0FED8B1DFB7F87826C19EA8E41670C680491C0603A

FILER EIN	AGENCY CODE	FILING DATE	HASHED VALUE
NYCHAM0033	996	07/24/2008	553B47C6A25102FB57EED2E53814DF8FA68385E275EFF19DAD6B6DC4D470E7A
NYCHAM0154	996	08/22/2008	92CF16A84ABCF61AFCA9B0A03486B2D9D175E184F9B9746C23173A3B93A456
NYCHAM0192	996	08/13/2008	7F0E2E6F50E21675223990405DEEFA8896E3F2A94347D262CDCF769F8512439A
NYCHAM0219	996	08/22/2008	E7E31FC0AF3BCFA846650DBF8E840754D017875D09141C3EB321DED756342669
NYCHAM0322	996	08/05/2008	801DA45205B54DB7B6D003C08D8A803BF469B5500918547A8A58A6AA7A94CFD1
NYCHAM0430	996	08/27/2008	9A7C630F9BDE85948E4C31EF2E28DB9E3DC20929725DBD827BF070F49740F8
NYCHAM0766	996	08/27/2008	25A024C1671B78A4BD4C361EFA5CD8AD4A1627EDE19B349C26907F9590F924E
NYCHAM0811	996	08/22/2008	AE08187B5CC57CAB7D063B6C20FF81CE560BCFCEDBBEF9347EA5136EA1B1963
NYCHAM1235	996	08/19/2008	B3D7629476A7B22FD9F013172EDCC0A0607C7BC444A7D95C77FFD25C74B283E
NYCHAM1247	996	08/22/2008	20F7FE938AD23FDAEC1B3D0720AD1A2024DA7DFDB544F3C3642357C9DBBC45326
NYCHAM1390	996	08/22/2008	C04B5EAO8BE8579123B2ACD0A7E7FA2EED0D6737606CC620AB3135B899CDE8
NYCHAM1427	996	08/21/2008	0CBE2C9EBD7DD4784F6C07BEC11552FB6E08FDF840FB270ECCD39A9A14453F7
NYCHAM1499	996	08/18/2008	04B6645FDF8568B275D249C9A501DFDC34708B74EFD5ED2FD1BFE14C76D25FF
NYCHAM1643	996	08/28/2008	0FBE30FF63702466CD1F8B57AC3F0580921005DA194DADB47EC280314A70866
NYCHAM1697	996	07/30/2008	0038B1D1E46543DB515EAEBA5A576ED5F43D91C54118090FC2D27ABBA4F0624
NYCHAM1779	996	08/15/2008	9FC756712E9B47A8CE99BB25098BEFE2EED12C0E2D23A0CAF43CC7CEAE858C8
NYCHAM1948	996	08/29/2008	3B72A4ED9638631EB79F9CD607A30216A71B374E9464F5C323768D743144ADF5
NYCHAM1972	996	07/28/2008	956BF4B2483BE3E05A5B11B3AC9065E58FD7A9A7F864669665234068787FC58
NYCHAM2241	996	08/29/2008	C6B87FB4462FF1E22FFB43A64C36466C5D4F64130F31CC072F0CB340



Table with columns: FILER EIN, AGENCY CODE, FILING DATE, HASHED VALUE. Contains a long list of records with various alphanumeric values.

Table with columns: FILER EIN, AGENCY CODE, FILING DATE, HASHED VALUE. Contains a long list of records with various alphanumeric values, continuing from the first table.

Table with 4 columns: FILER EIN, AGENCY CODE, FILING DATE, HASHED VALUE. Contains multiple rows of data.

Table with 4 columns: FILER EIN, AGENCY CODE, FILING DATE, HASHED VALUE. Contains multiple rows of data.

ENVIRONMENTAL PROTECTION

NOTICE

The New York City Department of Environmental Protections Bureau of Water Supply - Watershed Lands and Community Planning is posting this notice for the annual adjustment to Fee Schedule for Revocable Land Use Permits. Each year, there is an annual adjustment to the fees NYC DEP charges for Revocable Land Use Permits. This annual adjustment is based on the United States Bureau of Labor Statistic's Consumer Price Index (CPI - W). For 2009, the annual adjustment is 5.8 %. For a copy of the Fee Schedule, contact Judy Lapiner, Permit Specialist, (914) 742-2076, jlapiner@dep.nyc.gov, 465 Columbus Ave., Suite 350, Valhalla, NY 10595-1336.

j12-16

HOUSING PRESERVATION & DEVELOPMENT

NOTICE

OFFICE OF PRESERVATION SERVICES CERTIFICATION OF NO HARASSMENT UNIT

REQUEST FOR COMMENT ON APPLICATION FOR CERTIFICATION OF NO HARASSMENT PURSUANT TO LOCAL LAW 19 OF 1983

DATE OF NOTICE: January 9, 2009

TO: OCCUPANTS, FORMER OCCUPANTS AND OTHER INTERESTED PARTIES OF

Table with 3 columns: Address, Application #, Inquiry Period. Lists addresses and application details.

The Department of Housing Preservation and Development has received an application for a certification that during the inquiry period noted for the premises above, that no harassment has occurred at such premises in the form of threats, use of physical force, deprivation of essential services such as heat, water, gas or electric, or by any other conduct intended to cause persons to vacate the premises or waive rights related to their occupancy. Upon the issuance of a Certification, an owner can legally convert the premises to non-single room occupancy use.

Comments as to whether harassment has occurred at the premises should be submitted to the Anti-Harassment Unit, 100 Gold Street, 3rd Floor, New York, NY 10038, by letter postmarked not later than 30 days from the date of this notice or by an in-person statement made within the same period. To schedule an appointment for an in-person statement call (212) 863-8272.

j9-16

OFFICE OF THE MAYOR

NOTICE



THE CITY OF NEW YORK OFFICE OF THE MAYOR NEW YORK, N.Y. 10007

PROCLAMATION OF ELECTION

As a result of the resignation of Hiram Monserrate from the City Council, effective December 31, 2008, a vacancy has been created in the seat he has held as a Council Member for the twenty-first Council district. Accordingly, pursuant to the authority vested in me by Section 25(b)(1) and 25(b)(6) of the New York City Charter, and in order to facilitate maximum voter participation, I hereby proclaim that a special election shall be held in the twenty-first council district on February 24, 2009 to elect a council member to serve until December 31, 2009. Pursuant to Section 25(b)(7) of the Charter, nomination of candidates in this election shall be by independent nominating petition.

DATED: January 3, 2009

Signature of Michael R. Bloomberg, Mayor



THE CITY OF NEW YORK OFFICE OF THE MAYOR NEW YORK, N.Y. 10007

PROCLAMATION OF ELECTION

As a result of the resignation of Michael E. McMahon from the City Council, effective January 2, 2009, a vacancy has been created in the seat he has held as a Council Member for the forty-ninth Council district. Accordingly, pursuant to the authority vested in me by Section 25(b)(1) and 25(b)(6) of the New York City Charter, and in order to facilitate maximum voter participation, I hereby proclaim that a special election shall be held in the forty-ninth district on February 24, 2009 to elect a council member to serve until December 31, 2009. Pursuant to Section 25(b)(7) of the Charter, nomination of candidates in this election shall be by independent nominating petition.

DATED: January 3, 2009

Signature of Michael R. Bloomberg, Mayor



THE CITY OF NEW YORK OFFICE OF THE MAYOR NEW YORK, N.Y. 10007

PROCLAMATION OF ELECTION

As a result of the resignation of Joseph P. Addabbo, Jr. from the City Council, effective December 31, 2008, a vacancy has been created in the seat he has held as a Council Member for the thirty-second Council district. Accordingly, pursuant to the authority vested in me by Section 25(b)(1) and 25(b)(6) of the New York City Charter, and in order to facilitate maximum voter participation, I hereby proclaim that a special election shall be held in the thirty-second council district on February 24, 2009 to elect a council member to serve until December 31, 2009. Pursuant to Section 25(b)(7) of the Charter, nomination of candidates in this election shall be by independent nominating petition.

DATED: January 3, 2009

Signature of Michael R. Bloomberg, Mayor

j15

LATE NOTICE

CITYWIDE ADMINISTRATIVE SERVICES

CONTRACTS

SOLICITATIONS

Construction Related Services

BID EXTENSION: CONSTRUCTION MANAGEMENT RFP - Request for Proposals - PIN# 856080000512 - DUE 01-28-09 AT 11:00 A.M. - Proposal Extension and Issuance of the Addendum#1: The revised proposal submission due date is January 28, 2009 at 11:00 A.M.

An addendum has been issued to the Request for Proposals for Construction Management in the Boroughs of (1) Manhattan and (2) The Bronx, Brooklyn, Queens and Staten Island as a requirements contract for Professional Services for projects at various facilities. PIN#: 856080000512.

Addendum#1 is available online at www.nyc.gov/cityrecord.

Use the following address unless otherwise specified in notice, to secure, examine or submit bid/proposal documents, vendor pre-qualification and other forms; specifications/blueprints; other information; and for opening and reading of bids at date and time specified above.

Department of Citywide Administrative Services One Centre Street, 18th Floor N., New York, NY 10007. Erkan Solak (212) 669-3530, esolak@dcas.nyc.gov

j15

COURT NOTICE MAPS FOR FIFTH AMENDED BROOKLYN CENTER URBAN RENEWAL PROJECT, PHASE 2

NOTES:

ALL STREET LINES ARE FINAL CITY MAP LINES, WHICH ARE THE SAME AS THE TAX MAP LINES FOR THE STREETS ON THIS MAP, UNLESS OTHERWISE NOTED. THIS MAP IS DRAWN IN ACCORDANCE WITH THE TAX MAP OF THE CITY OF NEW YORK IN THE BOROUGH OF BROOKLYN... TAX BLOCKS 146 AND 2107... AS SAID TAX MAP EXISTED MAY 19, 2008. SAID TAX BLOCKS ARE IN BROOKLYN TAX MAP SECTIONS 1 AND 7. ALL TAX MAP DIMENSIONS ARE IN FEET AND INCHES. ALL REAR LOT DIMENSIONS ARE APPARENTLY THE SAME AS FRONT LOT DIMENSIONS EXCEPT AS OTHERWISE NOTED. THE PARCELS TO BE ACQUIRED SHALL BE ACQUIRED SUBJECT TO ENCROACHMENTS, IF ANY, OF THE IMPROVEMENTS, STRUCTURES AND APPURTENANCES STANDING OR MAINTAINED PARTLY UPON SAID PARCELS AND PARTLY UPON THE LANDS AND PREMISES ADJOINING THE SAME SO LONG AS SUCH ENCROACHMENTS SHALL STAND. THE PARCELS TO BE ACQUIRED IN BLOCK 2107 SHALL BE ACQUIRED SUBJECT TO ANY AND ALL EASEMENTS THAT BURDEN THESE PARCELS AND BENEFIT THE METROPOLITAN TRANSPORTATION AUTHORITY AND NEW YORK CITY TRANSIT.

LEGEND

Legend table with 4 columns: Symbol, Description, Value/Dimension, Description. Includes items like TAX BLOCK NUMBER (2107), TAX LOT NUMBER (15), ACQUISITION LINE, TAX LOT LINE, DAMAGE PARCEL NUMBER (9), and DIMENSION ALONG ACQUISITION LINE (273'-5").

ASSISTANT COMMISSIONER OF PLANNING HOUSING PRESERVATION AND DEVELOPMENT 10/17/08 DATE APPROVED BY THE CITY COUNCIL RESOLUTION NO. 45-A, DATED JUNE 28, 2004 APPROVED BY THE MAYOR CALENDAR NO. 18, DATED JUNE 30, 2004

THE CITY OF NEW YORK DEPARTMENT OF HOUSING PRESERVATION AND DEVELOPMENT OFFICE OF PLANNING ACQUISITION MAP SHOWING REAL PROPERTY TO BE ACQUIRED IN FEE SIMPLE FOR THE FIFTH AMENDED BROOKLYN CENTER PHASE 2 URBAN RENEWAL PROJECT IN THE BOROUGH OF BROOKLYN CITY OF NEW YORK SHEET 1 OF 4

COURT NOTICE MAPS FOR FIFTH AMENDED BROOKLYN CENTER URBAN RENEWAL PROJECT, PHASE 2

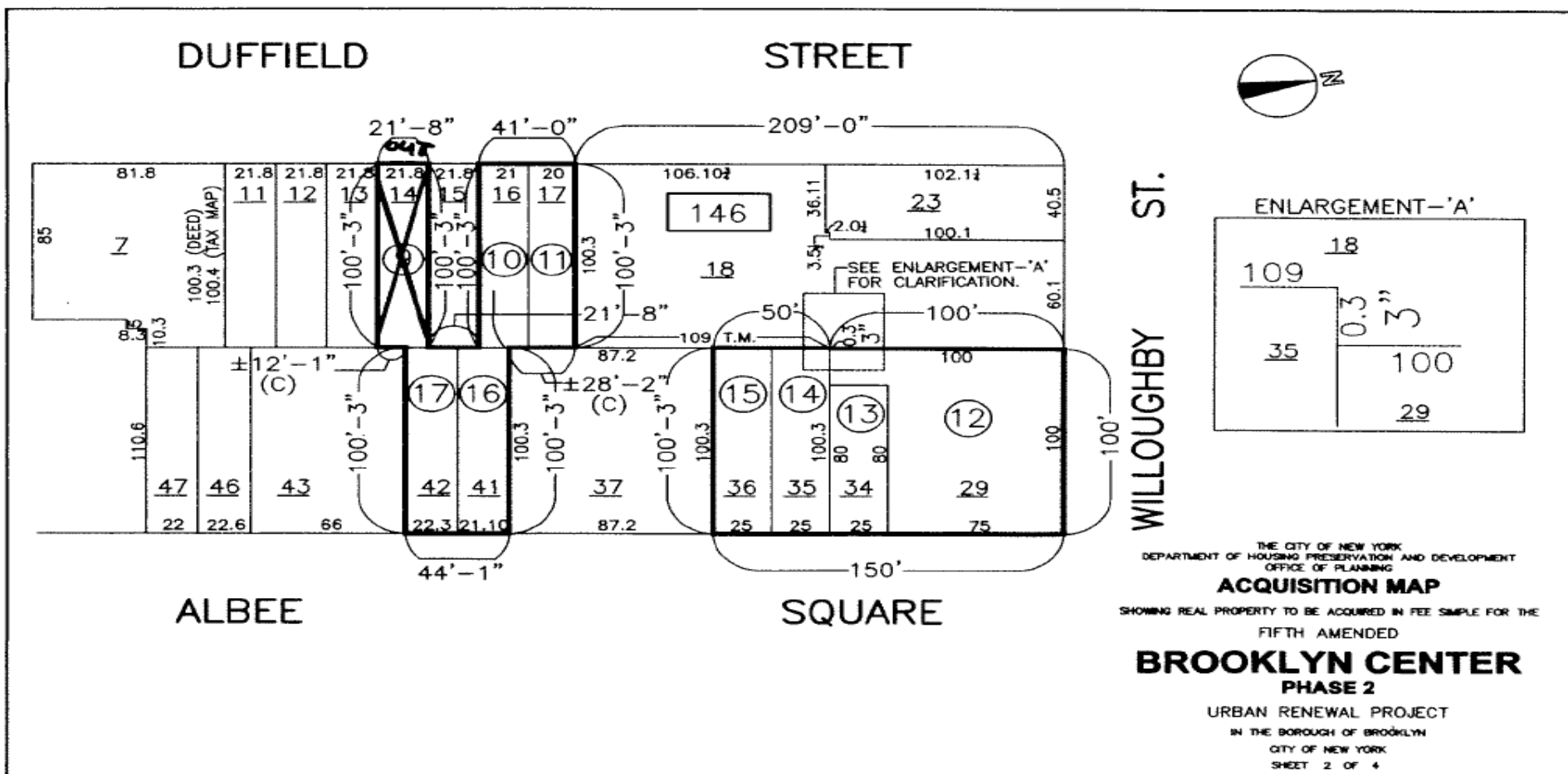
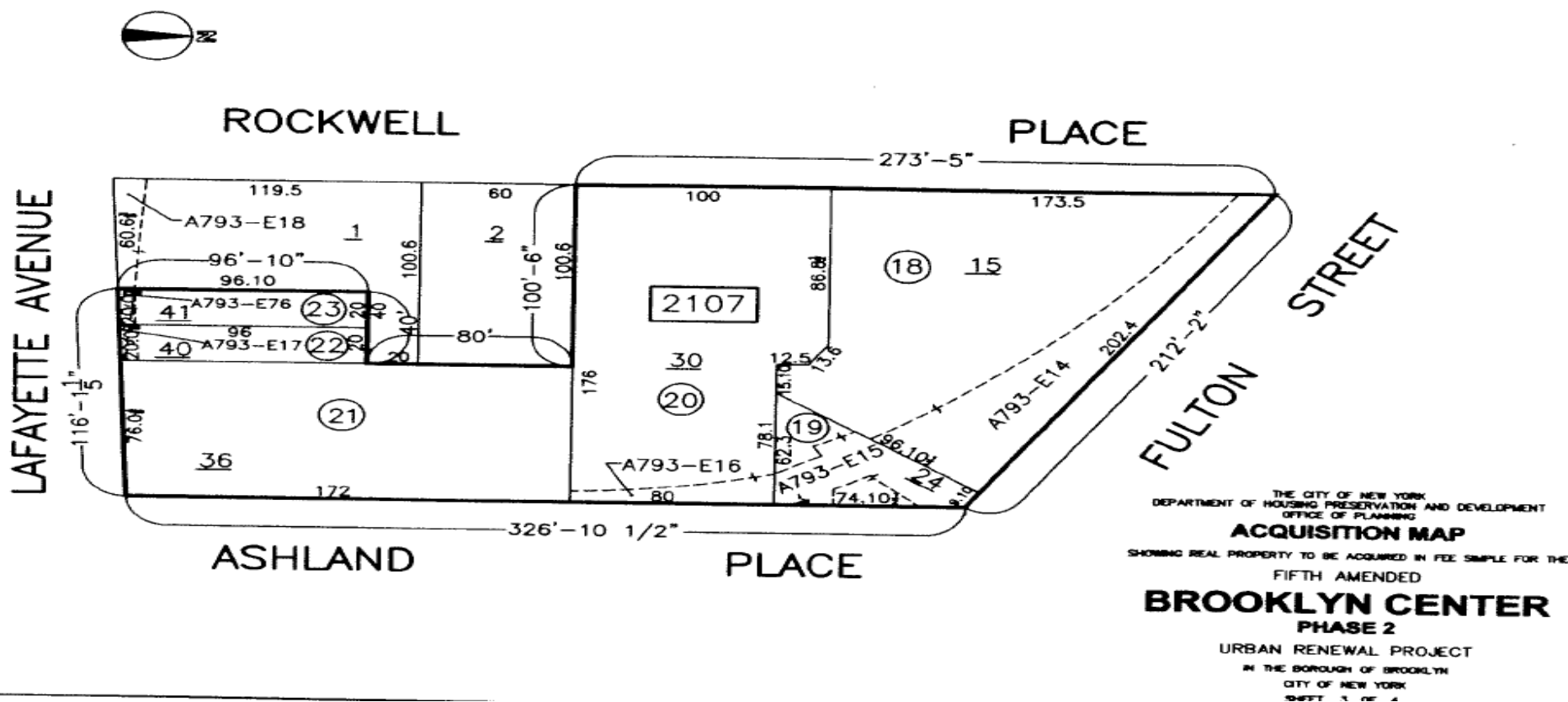

BROOKLYN CENTER URBAN RENEWAL PROJECT, 5th AMENDED, PHASE 2

NOTE: Parcel numbers are a continuation from the Phase 1 map.

Parcel No.	Tax Block	Tax Lot	Property Address	(Reputed) Property Owner	Transitional Assessed Valuations					Actual Assessed Valuations		
					06/07 Land	06/07 Total	07/08 Land	07/08 Total	08/09 Land	08/09 Total	08/09 Land	08/09 Total
<del>9</del>	<del>146</del>	<del>11</del>	<del>223 DUFFIELD STREET</del>	<del>223 DUFFIELD REALTY</del>	<del>\$66,110</del>	<del>\$66,110</del>	<del>\$76,110</del>	<del>\$76,110</del>	<del>\$63,168</del>	<del>\$63,168</del>	<del>\$166,000</del>	<del>\$166,000</del>
10	146	16	225 DUFFIELD STREET	YOUNG BANG	\$52,110	\$87,930	\$50,580	\$116,550	\$49,050	\$135,810	\$49,050	\$181,800
11	146	17	223 DUFFIELD STREET	R.L. GOLDMAN BRL TRUST	\$7,124	\$19,016	\$7,536	\$20,156	\$8,229	\$21,365	\$8,229	\$21,365
12	146	29	116 WILLOUGHBY ST.	ULTRA EQUITIES CO.	\$222,750	\$298,440	\$225,000	\$319,050	\$227,250	\$316,800	\$234,000	\$305,550
13	146	34	402 ALBEE SQUARE	EMAN REALTY CORP.	\$13,822	\$70,935	\$4,996	\$76,609	\$5,515	\$82,732	\$5,515	\$82,732
14	146	35	404 ALBEE SQUARE	EMAN REALTY CORP.	\$47,844	\$178,090	\$41,292	\$237,940	\$34,740	\$258,280	\$34,740	\$272,250
15	146	36	406 ALBEE SQUARE	EMAN REALTY CORP.	\$47,763	\$178,840	\$41,184	\$238,420	\$34,605	\$259,030	\$34,605	\$271,800
16	146	41	ALBEE SQUARE	VICTOR GIRARD	\$51,300	\$51,300	\$51,840	\$51,840	\$52,380	\$52,380	\$54,000	\$54,000
17	146	42	418 ALBEE SQUARE	MARYANN GIRARD	\$51,300	\$51,300	\$51,840	\$51,840	\$52,380	\$52,380	\$54,000	\$54,000
Total Assessed Valuations For Tax Block 146					<del>\$662,100</del>	<del>\$888,991</del>	<del>\$419,976</del>	<del>\$1,102,616</del>	<del>\$697,100</del>	<del>\$1,072,107</del>	<del>\$616,000</del>	<del>\$1,100,000</del>
					\$1,998,013	\$4,935,951	\$4,912,548	\$11,112,135	\$464,350	\$11,078,957	\$414,934	\$11,044,357
18	2107	15	590 Fulton Street	City of N.Y. - HPD	\$360,000	\$360,450	\$360,000	\$360,450	\$360,000	\$360,450	\$360,000	\$360,450
19	2107	24	600 Fulton Street	600 Fulton Corp.	\$41,544	\$114,030	\$60,264	\$106,836	\$78,984	\$206,753	\$138,600	\$270,000
20	2107	30	272 Ashland Place	City of N.Y. - HPD	\$312,120	\$312,120	\$312,120	\$312,120	\$312,120	\$312,120	\$312,750	\$312,750
21	2107	36	19 Lafayette Avenue	City of N.Y. - DCAS	\$283,050	\$283,050	\$283,500	\$283,500	\$283,500	\$283,500	\$283,500	\$283,500
22	2107	40	11 Lafayette Avenue	City of N.Y. - DCAS	\$43,750	\$43,750	\$44,013	\$44,013	\$44,019	\$44,019	\$44,055	\$44,055
23	2107	41	9 Lafayette Avenue	City of N.Y. - HPD	\$44,176	\$44,176	\$44,437	\$44,437	\$44,442	\$44,442	\$44,505	\$44,505
Total Assessed Valuations For Tax Block 2107					\$1,084,640	\$1,157,576	\$1,104,334	\$1,151,356	\$1,123,065	\$1,251,284	\$1,183,410	\$1,315,260

THE CITY OF NEW YORK DEPARTMENT OF HOUSING PRESERVATION AND DEVELOPMENT OFFICE OF PLANNING ACQUISITION MAP SHOWING REAL PROPERTY TO BE ACQUIRED IN FEE SIMPLE FOR THE FIFTH AMENDED BROOKLYN CENTER PHASE 2 URBAN RENEWAL PROJECT IN THE BOROUGH OF BROOKLYN CITY OF NEW YORK SHEET 4 OF 4

## READER'S GUIDE

The City Record (CR) is, published each business day and includes notices of proposed New York City procurement actions, contract awards, and other procurement-related information. Solicitation notices for most procurements valued at or above \$100,000 for information technology and for construction and construction related services, above \$50,000 for other services, and above \$25,000 for other goods are published for at least one day. Other types of procurements, such as sole source, require notice in the City Record for five consecutive days. Unless otherwise specified, the agencies and offices listed are open for business Mondays thru Fridays from 9:00 A.M. to 5:00 P.M. except legal holidays.

### NOTICE TO ALL NEW YORK CITY CONTRACTORS

The New York State Constitution ensures that all laborers, workers or mechanics employed by a contractor or subcontractor doing public work are to be paid the same wage rate that prevails in the trade where the public work is being done. Additionally, New York State Labor Law §§ 220 and 230 provide that a contractor or subcontractor doing public work in construction or building service must pay its employees no less than the prevailing wage. Section 6-109 (the Living Wage Law) of the New York City Administrative Code also provides for a "living wage", as well as prevailing wage, to be paid to workers employed by City contractors in certain occupations. The Comptroller of the City of New York is mandated to enforce prevailing wage. Contact the NYC Comptrollers Office at [www.comptroller.nyc.gov](http://www.comptroller.nyc.gov), click on Labor Law Schedules to view rates.

New York City's "Burma Law" (Local Law No. 33 of 1997) No Longer to be Enforced. In light of the United States Supreme Court's decision in **Crosby v. National Foreign Trade Council**, 530 U.S. 363 (2000), the City has determined that New York City's Local Law No. 33 of 1997 (codified in Administrative Code Section 6-115 and Charter Section 1524), which restricts City business with banks and companies doing business in Burma, is unconstitutional. This is to advise, therefore, that the language relating to Burma contained in existing New York City contracts may not be enforced.

### CONSTRUCTION/CONSTRUCTION SERVICES OR CONSTRUCTION RELATED SERVICES

The City of New York is committed to achieving excellence in the design and construction of its capital program, and building on the tradition of innovation in architecture and engineering that has contributed to the City's prestige as a global destination.

### VENDOR ENROLLMENT APPLICATION

New York City procures approximately \$7 billion worth of goods, services, construction and construction-related services every year. The NYC Procurement Policy Board Rules require that agencies primarily solicit from established mailing lists called bidder/proposer lists. To register for these lists-free of charge-, prospective suppliers should fill out and submit the NYC-FMS Vendor Enrollment application.

- Online at [NYC.gov/selltonyc](http://NYC.gov/selltonyc)
- To request a hardcopy application, call the Vendor Enrollment Center at (212) 857-1680.

### Attention Existing Suppliers:

Even if you already do business with NYC agencies, be sure to fill out an application. We are switching over to citywide, centralized Bidders Lists instead of the agency-specific lists previously used to issue notices about upcoming contract opportunities. To continue receiving notices of New York City contract opportunities, you must fill out and submit a NYC-FMS Vendor Enrollment application. If you are uncertain whether you have already submitted an application, call us at (212) 857-1680.

### SELLING TO GOVERNMENT TRAINING WORKSHOP

New and experienced vendors are encouraged to register for a free training course on how to do business with New York City. "Selling to Government" workshops are conducted by the Department of Small Business Services, 110 William Street, New York, NY 10038. Morning and afternoon sessions are convened on the first Tuesday of each month. For more information, and to register, call (212) 618-8845.

### PRE-QUALIFIED LIST

New York City procurement policy permits agencies to develop and solicit from pre-qualified lists of vendors, under prescribed circumstance. When it is decided by an agency to develop a pre-qualified list, criteria for pre-qualification must be clearly explained in the solicitation and notice of the opportunity to pre-qualify for that solicitation must be published in at least five issues of the CR.

Information and qualification questionnaires for inclusion on such list may be obtained directly from the Agency Chief Contracting Officer at each agency, (see Vendor Information Manual). A completed qualification Questionnaire may be submitted to the Chief Contracting Officer at any time, unless otherwise indicated and action (approval or denial) shall be taken by the agency within 90 days from the date of submission. Any denial or revocation of pre-qualified status can be appealed to the Office of Administrative Trials and Hearings, (OATH), Section 3-11 of the Procurement Policy Board Rules describes the criteria for the general use of pre-qualified lists.

### NON-MAYORAL ENTITIES

The following agencies are not subject to Procurement Policy Board rules and do not follow all of the above procedures: City University, Department of Education, Metropolitan Transportation Authority, Health & Hospitals Corporation, Housing Authority. Suppliers interested in applying for inclusion on bidders list should contact these entities directly (see Vendor Information Manual) at the addresses given.

### PUBLIC ACCESS CENTER

The Public Access Center is available to suppliers and the public as a central source for supplier-related information through on-line computer access. The Center is located at 253 Broadway, 9th floor, in lower Manhattan, and is open Monday through Friday from 10:00 A.M to 3:00 P.M. For information, contact the Mayor's Office of Contract Services at (212) 788-0010.

### ATTENTION: NEW YORK CITY MINORITY AND WOMEN OWNED BUSINESS ENTERPRISES

Join the growing number of Minority and Women Owned Business Enterprises (M/WBEs) that are competing for New York City's business. In order to become certified for the program, your company must substantiate that it: (1) is at least fifty-one percent (51%) owned, operated and controlled by a minority or woman and (2) is either located in New York City or has a significant tie to New York City's business community. To obtain a copy of the certification application and to learn more about the program, contact the New York City Department of Small Business Services, 110 William Street, 2nd Floor, New York, New York 10038 (212) 513-6311.

### PROMPT PAYMENT

It is the policy of the City of New York to pay its bills promptly. The Procurement Policy Board Rules generally require that the City pay its bills within 30 days after the receipt of a proper invoice. The City now pays interest on all late invoices. The grace period that formerly existed was eliminated on July 1, 2000. However, there are certain types of payments that are not eligible for interest. These are listed in Section 4-06 of the Procurement Policy Board Rules. The Comptroller and OMB determine the interest rate on late payments twice a year, in January and in July.

### PROCUREMENT POLICY BOARD RULES

The Rules may also be accessed on the City Website, <http://NYC.GOV.Selltonyc>

### COMMON ABBREVIATIONS USED IN THE CR

The CR contains many abbreviations. Listed below are simple explanations of some of the most common ones appearing in the CR:

- AB ..... Acceptable Brands List
- AC ..... Accelerated Procurement
- AMT ..... Amount of Contract
- BL ..... Bidders List
- CSB ..... Competitive Sealed Bidding (including multi-step)
- CB/PQ ..... CB from Pre-qualified Vendor List
- CP ..... Competitive Sealed Proposal (including multi-step)
- CP/PQ ..... CP from Pre-qualified Vendor List
- CR ..... The City Record newspaper
- DA ..... Date bid/proposal documents available
- DUE ..... Bid/Proposal due date; bid opening date
- EM ..... Emergency Procurement
- IG ..... Intergovernmental Purchasing
- LBE ..... Locally Based Business Enterprise
- M/WBE ..... Minority/Women's Business Enterprise
- NA ..... Negotiated Acquisition
- NOTICE.... Date Intent to Negotiate Notice was published in CR
- OLB..... Award to Other Than Lowest Responsible & Responsive Bidder/Proposer
- PIN..... Procurement Identification Number
- PPB ..... Procurement Policy Board
- PQ ..... Pre-qualified Vendors List
- RS..... Source required by state/federal law or grant
- SCE ..... Service Contract Short-Term Extension
- DP ..... Demonstration Project
- SS ..... Sole Source Procurement
- ST/FED ..... Subject to State &/or Federal requirements

### KEY TO METHODS OF SOURCE SELECTION

The Procurement Policy Board (PPB) of the City of New York has by rule defined the appropriate methods of source selection for City procurement and reasons justifying their use. The CR procurement notices of many agencies include an abbreviated reference to the source selection method utilized. The following is a list of those methods and the abbreviations used:

- CSB ..... **Competitive Sealed Bidding** (including multi-step)  
*Special Case Solicitations / Summary of Circumstances:*
- CP ..... **Competitive Sealed Proposal** (including multi-step)
- CP/1 ..... Specifications not sufficiently definite
- CP/2 ..... Judgement required in best interest of City
- CP/3 ..... Testing required to evaluate
- CB/PQ/4 ....
- CP/PQ/4 .... **CB or CP from Pre-qualified Vendor List/** Advance qualification screening needed
- DP ..... Demonstration Project
- SS ..... **Sole Source Procurement/**only one source
- RS..... Procurement from a Required Source/ST/FED
- NA..... Negotiated Acquisition  
*For ongoing construction project only:*
- NA/8 ..... Compelling programmatic needs

- NA/9 ..... New contractor needed for changed/additional work
- NA/10 ..... Change in scope, essential to solicit one or limited number of contractors
- NA/11 ..... Immediate successor contractor required due to termination/default  
*For Legal services only:*
- NA/12 ..... Specialized legal devices needed; CP not advantageous
- WA ..... **Solicitation Based on Waiver/Summary of Circumstances** (Client Services/BSB or CP only)
- WA1 ..... Prevent loss of sudden outside funding
- WA2 ..... Existing contractor unavailable/immediate need
- WA3 ..... Unsuccessful efforts to contract/need continues
- IG ..... **Intergovernmental Purchasing** (award only)
- IG/F ..... Federal
- IG/S ..... State
- IG/O ..... Other
- EM ..... **Emergency Procurement** (award only) An unforeseen danger to:
- EM/A ..... Life
- EM/B ..... Safety
- EM/C ..... Property
- EM/D ..... A necessary service
- AC ..... **Accelerated Procurement/**markets with significant short-term price fluctuations
- SCE ..... **Service Contract Extension/**insufficient time; necessary service; fair price  
*Award to Other Than Lowest Responsible & Responsive Bidder or Proposer / Reason* (award only)
- OLB/a ..... anti-apartheid preference
- OLB/b ..... local vendor preference
- OLB/c ..... recycled preference
- OLB/d ..... other: (specify)

### HOW TO READ CR PROCUREMENT NOTICES

Procurement Notices in the CR are arranged by alphabetically listed Agencies, and within Agency, by Division if any. The notices for each Agency (or Division) are further divided into three subsections: Solicitations, Awards; and Lists & Miscellaneous notices. Each of these subsections separately lists notices pertaining to Goods, Services, or Construction.

Notices of Public Hearings on Contract Awards appear at the end of the Procurement Section. At the end of each Agency (or Division) listing is a paragraph giving the specific address to contact to secure, examine and/or to submit bid or proposal documents, forms, plans, specifications, and other information, as well as where bids will be publicly opened and read. This address should be used for the purpose specified UNLESS a different one is given in the individual notice. In that event, the directions in the individual notice should be followed. The following is a SAMPLE notice and an explanation of the notice format used by the CR.

## SAMPLE NOTICE:

### POLICE

#### DEPARTMENT OF YOUTH SERVICES

#### ■ SOLICITATIONS

*Services (Other Than Human Services)*

**BUS SERVICES FOR CITY YOUTH PROGRAM** – Competitive Sealed Bids – PIN# 056020000293 – DUE 04-21-03 AT 11:00 A.M.

*Use the following address unless otherwise specified in notice, to secure, examine or submit bid/proposal documents, vendor pre-qualification and other forms; specifications/blueprints; other information; and for opening and reading of bids at date and time specified above.*  
NYPD, Contract Administration Unit, 51 Chambers Street, Room 310, New York, NY 10007. Manuel Cruz (646) 610-5225.

☛ m27-30

ITEM	EXPLANATION
POLICE DEPARTMENT	Name of contracting agency
DEPARTMENT OF YOUTH SERVICES	Name of contracting division
■ SOLICITATIONS	Type of Procurement action
<i>Services (Other Than Human Services)</i>	Category of procurement
BUS SERVICES FOR CITY YOUTH PROGRAM	Short Title
CSB	Method of source selection
PIN # 056020000293	Procurement identification number
DUE 04-21-03 AT 11:00 am	Bid submission due 4-21-03 by 11:00 am; bid opening date/time is the same.
<i>Use the following address unless otherwise specified in notice, to secure, examine-submit bid/proposal documents; etc.</i>	Paragraph at the end of Agency Division listing giving contact information, or submit bid/information or and Agency Contact address
	NYPD, Contract Administration Unit 51 Chambers Street, Room 310 New York, NY 10007. Manuel Cruz (646) 610-5225.
☛	Indicates New Ad
m27-30	Date that notice appears in City Record

### NUMBERED NOTES

**Numbered Notes are Footnotes.** If a Numbered Note is referenced in a notice, the note so referenced must be read as part of the notice. **1.** All bid deposits must be by company certified check or money order made payable to Agency or Company.