

**Calgary**



## **Innovation, Efficiencies, and Cost Savings**

**Sharon Fleming, Director, Fleet Services  
The City of Calgary**







# Calgary's Political Landscape





## Four Distinct Fleets



FLEET SERVICES



CALGARY TRANSIT



CALGARY FIRE DEPARTMENT



CALGARY POLICE SERVICE



# Calgary



**1,057**

Heavy fleet trucks



**1,607**

Light fleet vehicles



**1,317**

Motorized/Specialized  
equipment

**35**  
million

kilometres driven







# Utilization Journey

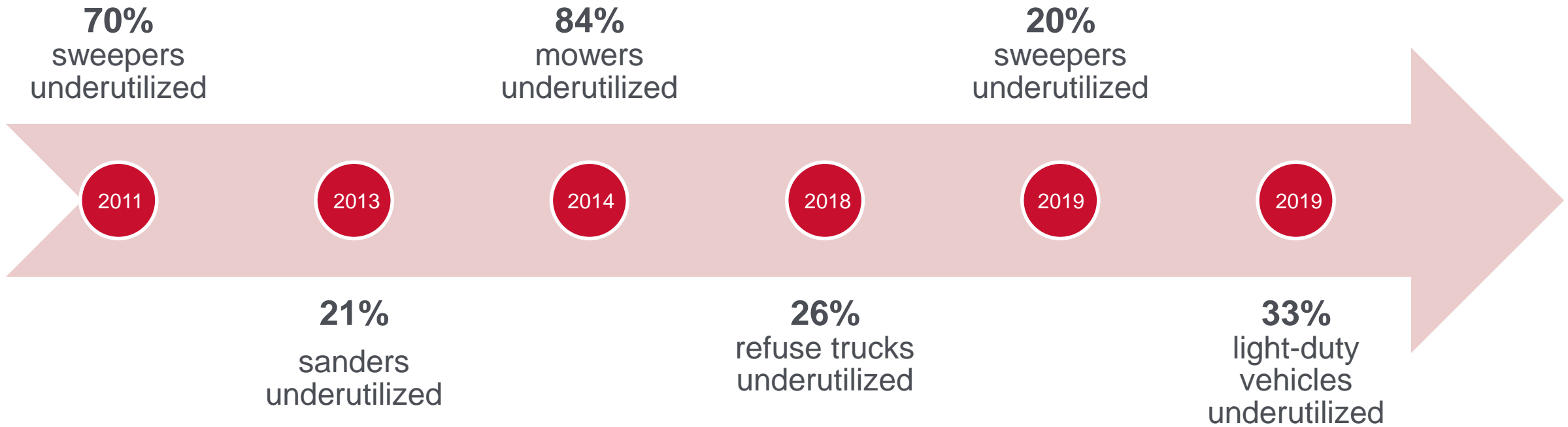



**How can we improve  
utilization and reduce costs?**





1

Multi-Purpose Trucks

2

Flex Fleet

3

Seasonal Leasing



# Multi-Purpose Truck

The City of Calgary's Award Winning Design





# Most Innovative Fleet Management Strategy

*The City of Calgary in Canada won the award for its patented asphalt carrier and recycler built on a standardised multi-purpose vehicle platform, which has saved the City of Calgary millions in capital and operating costs while diverting tons of asphalt waste from landfill.*





Designing the **right**

**thing**

Designing the **thing**

**right**





- Seasonality of Calgary Roads maintenance
- Five distinct activities:
  - Snow clearing and sanding
  - Anti-icing
  - Dust suppression
  - Pothole repairs
  - Hauling material
- Single purpose units with low utilization





# Slip in Components

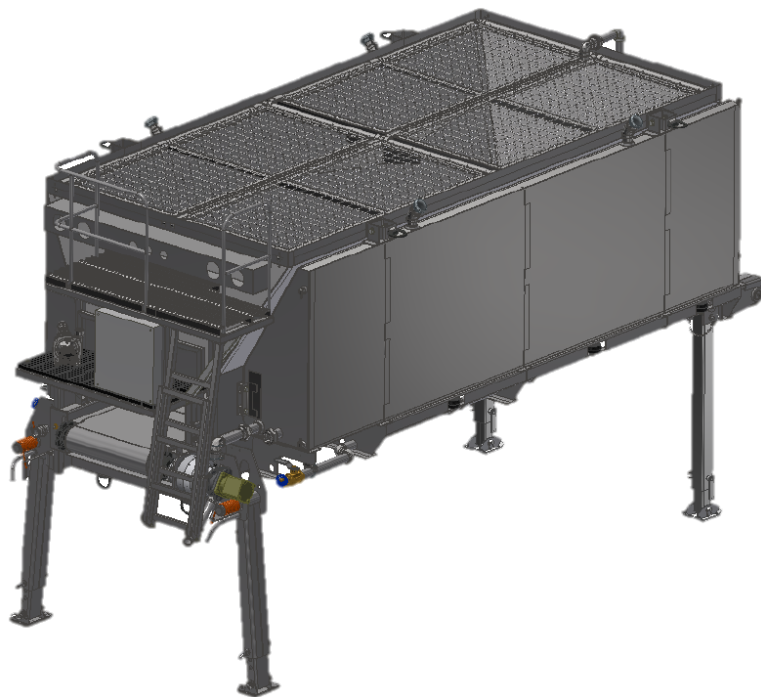

Stainless Steel Sander

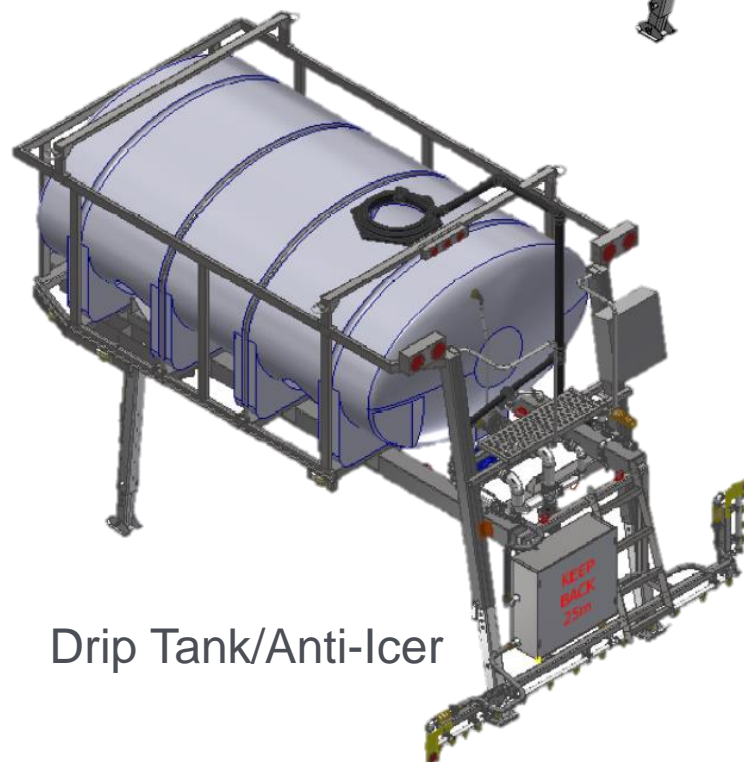

Drip Tank/Anti-Icer

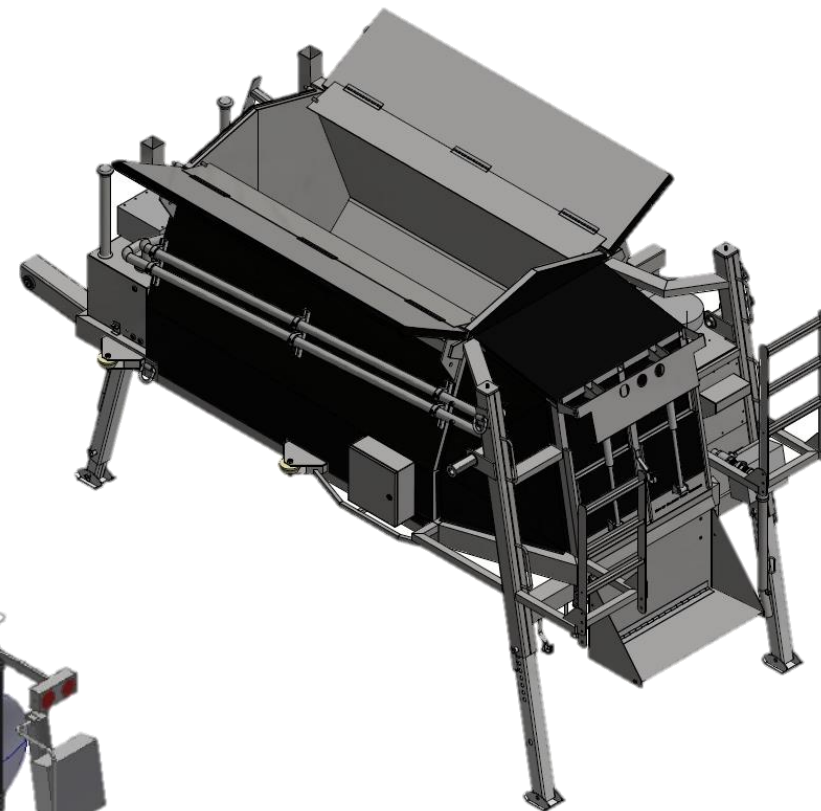

Asphalt Carrier/Recycler







# Patent

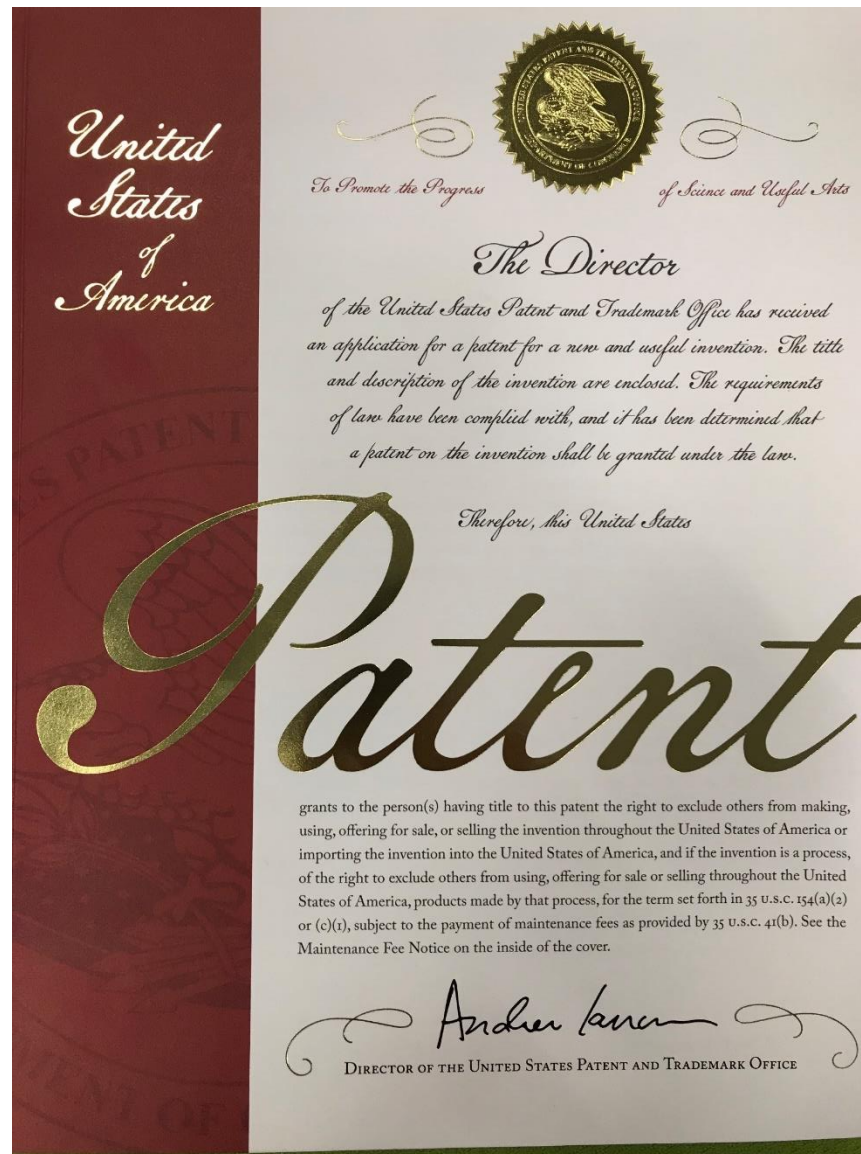





**Increased Utilization**

**12**

Trucks replacing 24 single-purpose units

**Asphalt Recycling**

**\$800,000**

Annual savings

**Cost Savings**

**\$5,000,000**

Operating and capital savings over 5 years

**Waste Diversion**

**8,500**

Tonnes of wasted diverted



- Licensing
- Keep innovating!





Calgary



# Flex Fleet

## The City of Calgary's Car Share Project





# Problem







# **Solution: Flex Fleet**





# Implementation Plan

- 2020 - Proof of Concept (10 vehicles)
- 2021 – Phase 1 (25 vehicles)
- 2022 – Phase 2 (60 vehicles)
- 2023 – Phase 3 (150 vehicles)

Ford Escape  
Side view



Ford Escape  
Rear view



Ford Escape  
Front view





- Vehicle immobilized until valid tap in
- Integration with City ID cards
- Access based on driver's license class, training, and approvals
- Ability for on-demand (walk up) and scheduled trips
- Mobile app for booking and locating vehicles
- GPS tracking and geo-fencing capabilities
- Sub-pool functionality





Innovative

Reduces our  
carbon  
footprint

Cost Efficient





# Seasonal Leasing

## The City of Calgary's Approach







# Seasonal Applications

SWEEPERS



SANDERS



REFUSE TRUCKS



MOWERS





# Seasonal Utilization

Sweepers



Sanders

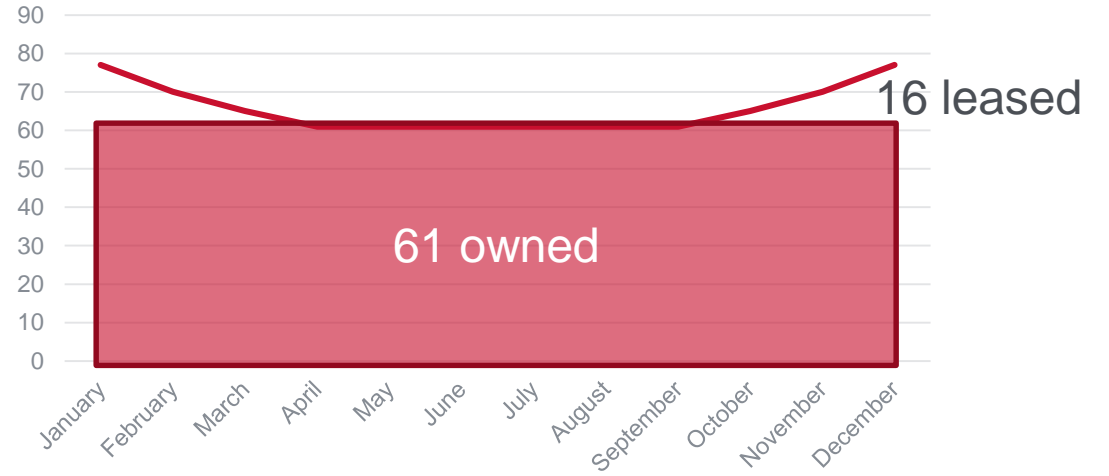

Organics Collection

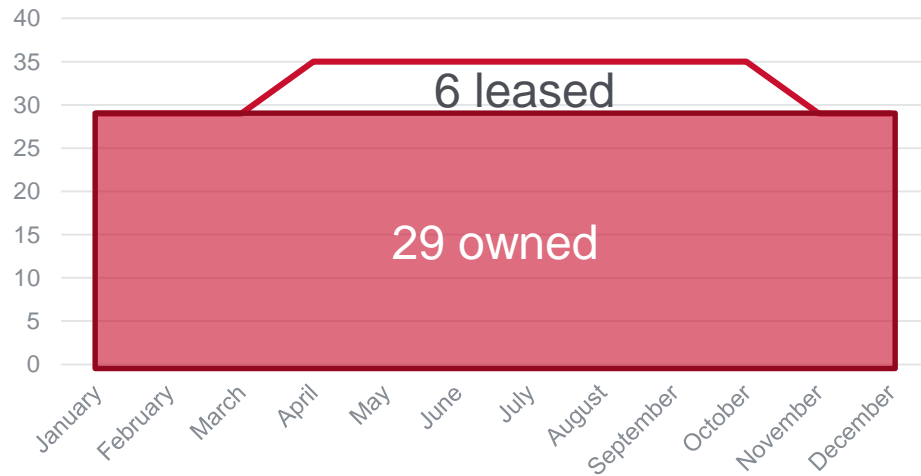

Mowers





# Solution – Seasonal Leasing

- Hybrid model to balance owned vs leased
- Leased newer units

## Benefits:

- Reduced unplanned failures
- Reduced maintenance costs
- Increased uptime (availability)





# Summary of Savings

	Total Savings Over Life	Annual Savings
<b>1</b> Multi-Purpose Truck	5 million \$CAD 2.9 million £GBP	1 million \$CAD 590 thousand £GBP
<b>2</b> Flex Fleet	8.4 million \$CAD 4.9 million £GBP	1.2 million \$CAD 700 thousand £GBP
<b>3</b> Seasonal Leasing	7.2 million \$CAD 4.2 million £GBP	2 million \$CAD 1.2 million £GBP



4.2 million \$CAD

2.5 million £GBP





# Questions?