

CHAPTER 2: PURPOSE AND NEED AND PROJECT OVERVIEW

2.1 INTRODUCTION AND PROJECT IDENTIFICATION

The New York City Department of Environmental Protection (NYCDEP) is proposing to construct a vertical water supply shaft, Shaft 33B, to bring water from City Tunnel No. 3 to the local water distribution system in East Midtown and the Upper East Side in Manhattan. Once constructed, the shaft would be an unmanned, underground facility capable of conveying water from the new City Tunnel No. 3 to the surface distribution system that serves East Midtown and the Upper East Side. A new water supply shaft for City Tunnel No. 3 is critical for these two areas, to address water supply problems, provide adequate supply to meet the neighborhoods' heavy demand, and to provide redundancy to the existing water supply system.

City Tunnel No. 3 is currently under construction beneath Manhattan as well as in Brooklyn and Queens. The new tunnel is being constructed in part to facilitate inspection and repair of City Tunnel No. 1, which is currently the primary source of Manhattan's water supply. City Tunnel No. 1 was activated in 1917 and has been in continuous operation for almost 90 years, but before it can be inspected or repaired, an additional supply of water (City Tunnel No. 3) must be provided. The new City Tunnel No. 3 will also provide other important benefits, by increasing distribution system redundancy and maintaining sufficient water pressure in neighborhoods it serves. For the East Midtown area east of Park Avenue, the new water supply from City Tunnel No. 3 will improve water reliability as well, addressing an important problem in this area.

Shaft 33B will be the water supply shaft through which vertical water pipes will bring water from City Tunnel No. 3 to the local distribution system in this part of East Midtown. New water main connections would run from Shaft 33B to the local trunk main, the large distribution main under Third Avenue used to supply all water in the area. Shaft 33B is the tenth and final shaft to be sited for City Tunnel No. 3's Stage 2 Manhattan Leg. City Tunnel No. 3, which is currently under construction. The final alignment of City Tunnel No. 3 to connect to Shaft 33B would be routed to meet the proposed Shaft 33B Site when the environmental review process is completed and a decision is made regarding the location of the shaft. Once completed, Shaft 33B would be an unmanned, underground facility that would convey water from City Water Tunnel No. 3 to the surface distribution system that serves Manhattan residents.

Shaft 33B is subject to environmental review pursuant to New York City's Environmental Quality Review (CEQR) process. This EIS was prepared pursuant to CEQR to examine the potential environmental impacts associated with construction and operation of Shaft 33B at a preferred Shaft Site and at several alternative Shaft Sites.

This Chapter discusses the following:

- Section 2.2: The purpose and need for Shaft 33B;
- Section 2.3: The preferred location and alternative locations for Shaft 33B;
- Section 2.4: An overview of shaft and water main connection components;
- Section 2.5: Construction activity required for Shaft 33B and its water main connections;
- Section 2.6: Activation of the shaft;

- Section 2.7: Operation and maintenance;
- Section 2.8: Required permits and approvals;
- Section 2.9: Environmental review; and
- Section 2.10: Organization of this EIS.

This information serves as the basis for the impact assessments included in the following Chapters of this EIS. See Section 2.10, below, for information on the organization of the other Chapters of this EIS.

2.2 PROJECT PURPOSE AND NEED

The proposed Shaft 33B would be a critical component of the City’s water supply and distribution system. It is needed to deliver water from the new City Tunnel No. 3, which is currently being constructed in Manhattan, to the local water distribution system in the northern part of East Midtown. By adding a new water distribution system element in this neighborhood, Shaft 33B would improve water reliability and water supply in the area it would serve. It would also meet the City’s goal of providing water supply redundancy in this area. With water supply from City Tunnel No. 3 in place in this area, there would be no service disruptions or dramatic changes in pressure when City Tunnel No. 3, Stage 2 Manhattan Leg comes on-line and replaces service from City Tunnel No. 1.

2.2.1 New York City’s Water Supply and Distribution System

New York City’s water supply system is one of the largest surface storage and supply complexes in the world. It is the primary drinking water source for approximately half the population of New York State, including most of the 8 million residents of New York City and an additional one million residents of upstate counties. The drinking water system currently delivers over approximately 1.3 billion gallons of drinking water every day to consumers in New York City.

This drinking water system flows from three watersheds: the Croton, Delaware, and Catskill (Figure 2-1). Together, these watershed encompass a 1,968-square-mile area, and all or parts of eight different counties in New York—Delaware, Dutchess, Greene, Putnam, Schoharie, Sullivan, Ulster, and Westchester—and a small portion of western Fairfield County, Connecticut.

The three upstate reservoir systems include 19 reservoirs and three controlled lakes with a storage capacity of approximately 580 billion gallons. The system’s water supply is transported through an extensive system of tunnels and aqueducts. Water is conveyed to the City from the reservoirs in the Croton, Catskill and Delaware Systems by gravity through large aqueducts to “balancing” reservoirs in Westchester County and in the City. Within the City, water is distributed through two major tunnels (City Tunnels No. 1 and 2) and the New Croton Aqueduct. A third tunnel (City Tunnel No. 3) is now under construction to supplement the two older tunnels.



Map Document: (S:\Projects\2175158\GIS_Figures\Start_33B\EIS_Field_Work\Fig_1_NYC_DEP_Water_Supply.mxd)
10/21/2005 -- 9:55:53 AM



NEW YORK CITY DEPARTMENT OF ENVIRONMENTAL PROTECTION
PROPOSED SHAFT 33B TO CITY TUNNEL NO.3
STAGE 2 - MANHATTAN LEG
PURPOSE AND NEED AND PROJECT OVERVIEW
NEW YORK CITY WATER SUPPLY SYSTEM

FIGURE 2-1

Aqueducts and Balancing Reservoirs

Water from the Catskill and Delaware Systems is transmitted by gravity, through the 92-mile-long Catskill Aqueduct and the 85-mile-long Delaware Aqueduct to the Kensico Reservoir, where it is mixed and conveyed to the Hillview Reservoir in Yonkers. From the Hillview Reservoir, the water enters City Tunnels No. 1 and 2 for distribution throughout the City.

In addition, Manhattan also receives a limited supply of water through the Croton System, which distributes water from the Jerome Park Reservoir through a system of pipes extending down the East Side of Manhattan. Croton System water is transmitted by gravity from the Croton Reservoir by the 33-mile-long New Croton Aqueduct to the Jerome Park Reservoir in the Bronx. From Jerome Park Reservoir and from direct connections to the New Croton Aqueduct, trunk mains carry water to the service area.

Tunnels

City Tunnel No. 1

From the Hillview Reservoir, water from the Catskill and Delaware Systems is delivered into the City by City Tunnel No. 1, which is 18 miles long and extends south from the Hillview Reservoir through the West Bronx to Manhattan and Brooklyn. City Tunnel No. 1 is 200 to 750 feet underground and thus avoids interference with streets, buildings, subways, sewers, pipes and other underground infrastructure. Ranging in size from 11 to 15 feet in diameter, City Tunnel No. 1 has a capacity of approximately 1 billion gallons per day of water. Shafts along the tunnel connect with surface mains which deliver water to the distribution system. From two terminal shafts in Brooklyn, steel and standby cast iron pipelines extend into Queens and Staten Island, respectively. This tunnel went into service in 1917 and has been in continuous operation since.

City Tunnel No. 2

City Tunnel No. 2 also delivers Catskill and Delaware System water from the Hillview Reservoir. Approximately 200 to 800 feet below the street surface and 15 to 17 feet in diameter, City Tunnel No. 2 extends south from the Hillview Reservoir, east of City Tunnel No. 1, through the Bronx, under the East River at Rikers Island, through Queens and Brooklyn, and connects with Tunnel No. 1 at Fort Greene Park in Brooklyn as well as in downtown Brooklyn. City Tunnel No. 2 has a capacity of approximately 1 billion gallons per day and is 20 miles in length. Shafts, connected with surface mains, deliver water to the distribution system. City Tunnel No. 2 was activated in 1936 and has been operating continuously since that time.

Richmond Tunnel

Connecting to Tunnel No. 2 in Brooklyn is the 10-foot diameter, five-mile long Richmond Tunnel, which was completed in 1970 and carries water 900 feet beneath Upper New York Bay to Staten Island.

City Tunnel No. 3

A new water tunnel connecting the reservoir system to the City is currently under construction to enhance the adequacy and reliability of water transmission to the City in the future. This tunnel, on which construction began in 1970, will eventually span 60 miles and is expected to be complete in 2020. The primary reasons for constructing City Tunnel No. 3 are to do the following:

- Permit inspection and rehabilitation of City Tunnels No. 1 and 2, which must be taken out of service and drained of water to allow inspection;
- Provide water delivery alternatives to the City in the event of disruption in Tunnel No. 1 or 2; and
- Improve overall water supply delivery services and provide reliable and secure conveyance mechanisms for future City residents.

The operation of the new tunnel, City Tunnel No.3, will allow City Tunnels No. 1 and 2 to be drained, inspected, and repaired for the first time since they were put in operation in 1917 and 1936, respectively. The third tunnel is also critically important to maintain water deliveries at adequate flows and pressures and to increase redundancy throughout the water delivery system by providing additional interconnections between portions of the system.

The third water tunnel was originally conceived by the New York City Board of Water Supply (Water Board), previously responsible for the design, implementation and management of the City's water supply infrastructure. In 1978, the Water Board was merged into NYCDEP, which thereafter assumed responsibility for the planning and implementation of City Tunnel No. 3.

City Tunnel No. 3 is being built in four stages (Figure 2-2):

- **Stage 1:** The first stage of City Tunnel No. 3 was activated in 1998. This tunnel, ranging from 20 to 24 feet in diameter and located 250 to 800 feet below the surface, extends 13 miles from the Hillview Reservoir through the Bronx, into Manhattan, across Central Park, and east from the park under the East River to Roosevelt Island and Queens. Fourteen shafts bring water from the activated tunnel to the local distribution system.
- **Stage 2:** This stage, which includes Shaft 33B, will consist of two sections, both currently under construction—a Brooklyn/Queens Leg and a Manhattan Leg. The Brooklyn/Queens Leg will extend from the end of Stage 1 in Astoria, Queens to supply Queens, Brooklyn, and the Richmond Tunnel. The Manhattan Leg will include two portions. The south leg will extend south from the completed City Tunnel No. 3 valve chamber in Central Park into Lower Manhattan via the West Side, and will loop north again from near City Hall to a terminus near E. 4th Street at City Tunnel No. 1. The second segment of the Manhattan Leg, the north leg, will extend crosstown from the West Side (at Tenth Avenue near W. 35th Street) to the East Side (at Second Avenue near E. 35th Street) and continue north up the East Side to a terminus in East Midtown at Shaft 33B (Figure 2-3). Construction of the Queens/Brooklyn Leg of Stage 2 began in 1991, and is projected to be activated by 2008. Construction of the Manhattan Leg of Stage 2 began in October 2003 and is projected to be

Map Document: (S:\IP\Projects\2175158\GIS_Figures\Shaft_33B\GIS_Figures\Shaft_33B\DEP_Tunnel_Sections(AKRF)_BW.mxd)
 10/20/2005 - 4:13:50 PM

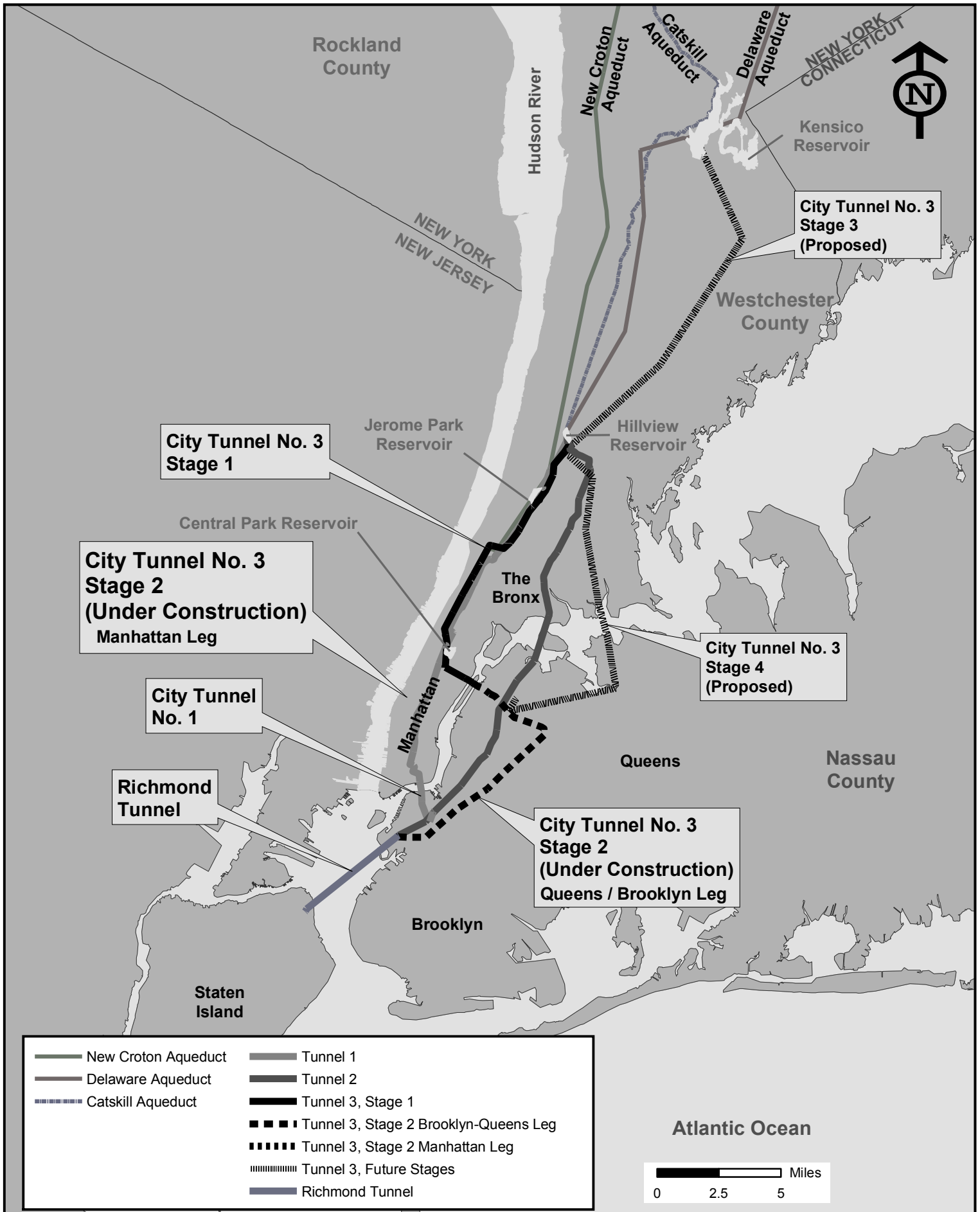

NEW YORK CITY DEPARTMENT OF ENVIRONMENTAL PROTECTION
PROPOSED SHAFT 33B TO CITY TUNNEL NO.3
STAGE 2 - MANHATTAN LEG
PURPOSE AND NEED AND PROJECT OVERVIEW
NEW YORK CITY WATER SUPPLY TUNNEL SYSTEM

FIGURE 2-2

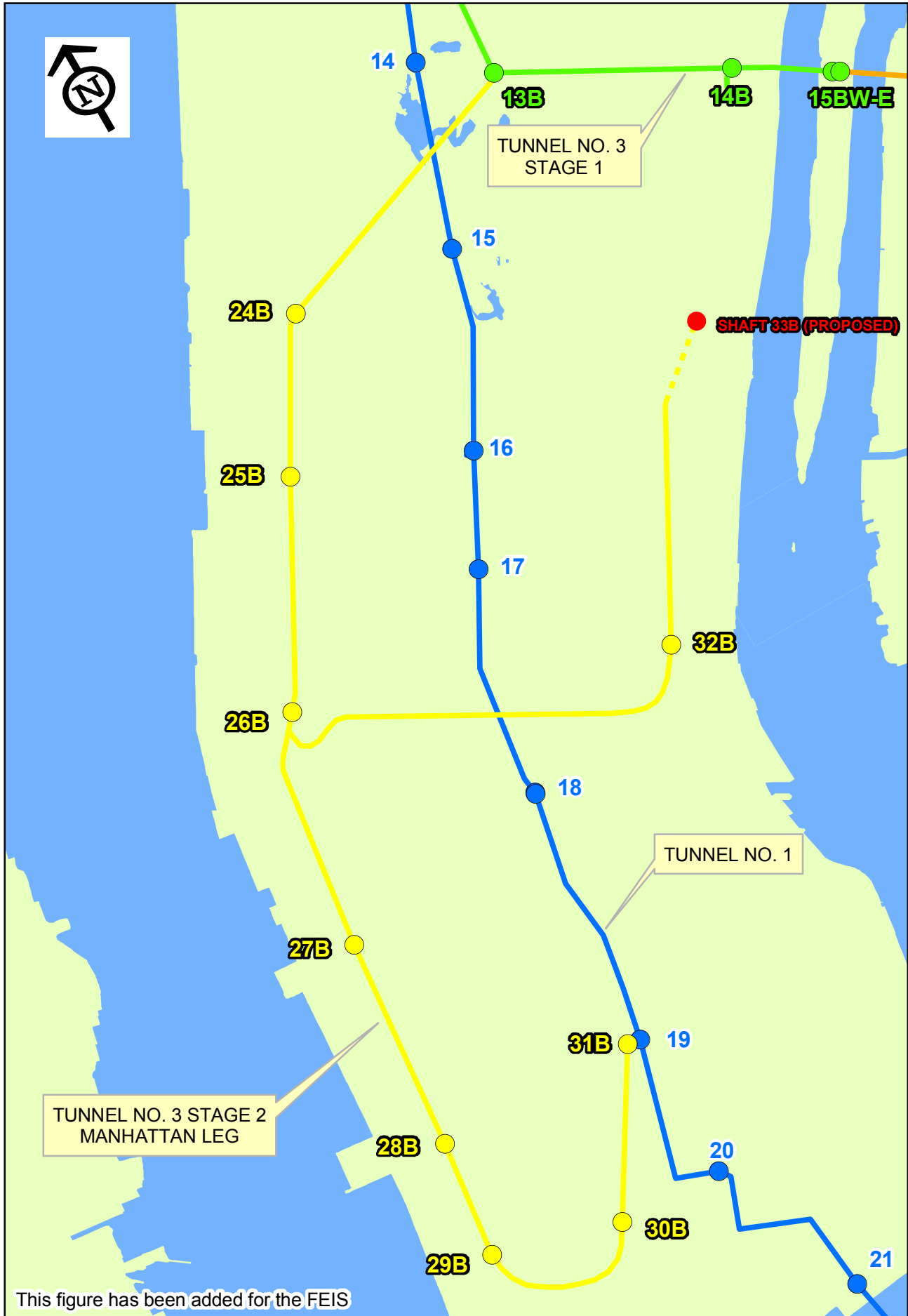

This figure has been added for the FEIS

Map Document: (S:\Projects\2175158\GIS_Figures\Shaft_33B\GIS_Field_Work\FAQ_Website\AKRF.mxd)
10/21/2005 -- 9:56:07 AM



NEW YORK CITY DEPARTMENT OF ENVIRONMENTAL PROTECTION
PROPOSED SHAFT 33B TO CITY TUNNEL NO. 3
STAGE 2 - MANHATTAN LEG
PURPOSE AND NEED AND PROJECT OVERVIEW
MANHATTAN LEG TUNNEL AND SHAFTS

FIGURE 2-3

activated by 2012. Upon completion of this stage, City Tunnel No. 1 can be closed for inspection.

- **Stage 3:** Stage 3 will extend from the Kensico Reservoir to meet the interconnecting chamber of Stage 1, south of the Hillview Reservoir. When completed, Stage 3 will be able to deliver water directly from the Kensico Reservoir to City Tunnel No. 3, or to the Hillview Reservoir for delivery to City Tunnels No. 1 and 2. When Stage 3 is completed, City Tunnel No. 3 will operate at greater pressure, induced by the higher elevation of the Kensico Reservoir. It will also provide an additional aqueduct to supply water to the City that will parallel the Delaware and Catskill Aqueducts.
- **Stage 4:** The final stage, if required, will extend from the northern terminus of Stage 1 in the Bronx southeast to the Queens portion of Stage 2.

Local Distribution System

Water is conveyed by the water tunnels from the upstate reservoirs to the City's local water distribution system, which consists of a grid network of water mains ranging in size from 6 to 84 inches in diameter. It contains almost 6,000 miles of pipe, 86,710 mainline valves and 97,800 fire hydrants. Like the aqueduct system, the distribution system was designed and built to provide flexibility and redundancy by permitting the exchange of water through localized parts of the system to meet varying demand and pressure requirements.

About 95 percent of the City's water is normally delivered by gravity, flowing from the higher elevation watersheds and reservoirs through the aqueducts and tunnels to the City distribution system without pumping. It is necessary to pump only the remaining 5 percent to areas of higher elevation to keep the pressure within this desired range.

The distribution system in each borough is divided into water pressure "zones" that have different levels of pressure in the pipes. These zones are determined chiefly by the local topography. The City's pressure zones are shown in Figure 2-4. Pressure zones are separated by boundary valves, which control the exchange of water between the zones. Pressure in each zone is maintained by "regulator" valves, also referred to as "regulators." Regulators typically reduce pressure from the Hillview Reservoir gradient to local distribution system needs and maintain a constant discharge pressure for water.

From the water tunnels, water reaches the surface distribution system via large-diameter shafts. These shafts house "risers," steel pipes encased in concrete that bring water to the surface. From the shafts, water is distributed via large "trunk" mains, typically ranging from 30 inches to 72 inches in diameter, which serve as the primary distribution system for water in each pressure zone. Water flows from trunk mains to smaller diameter distribution mains (typically, 24 inches in diameter or less) that serve smaller areas, and from those distribution mains to service connections that supply individual buildings.

In Manhattan, regulators are frequently located in the vicinity of the shafts, so that pressure is controlled at the point where water enters the pressure zone. In some locations in the City, particularly areas that are at higher elevations or farther from the closest shaft, unregulated water

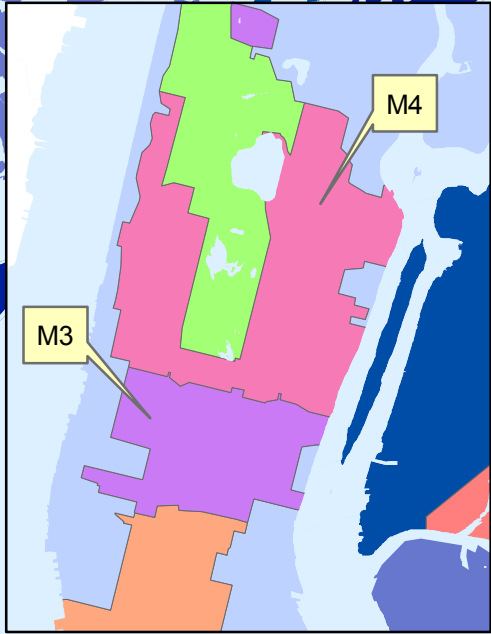
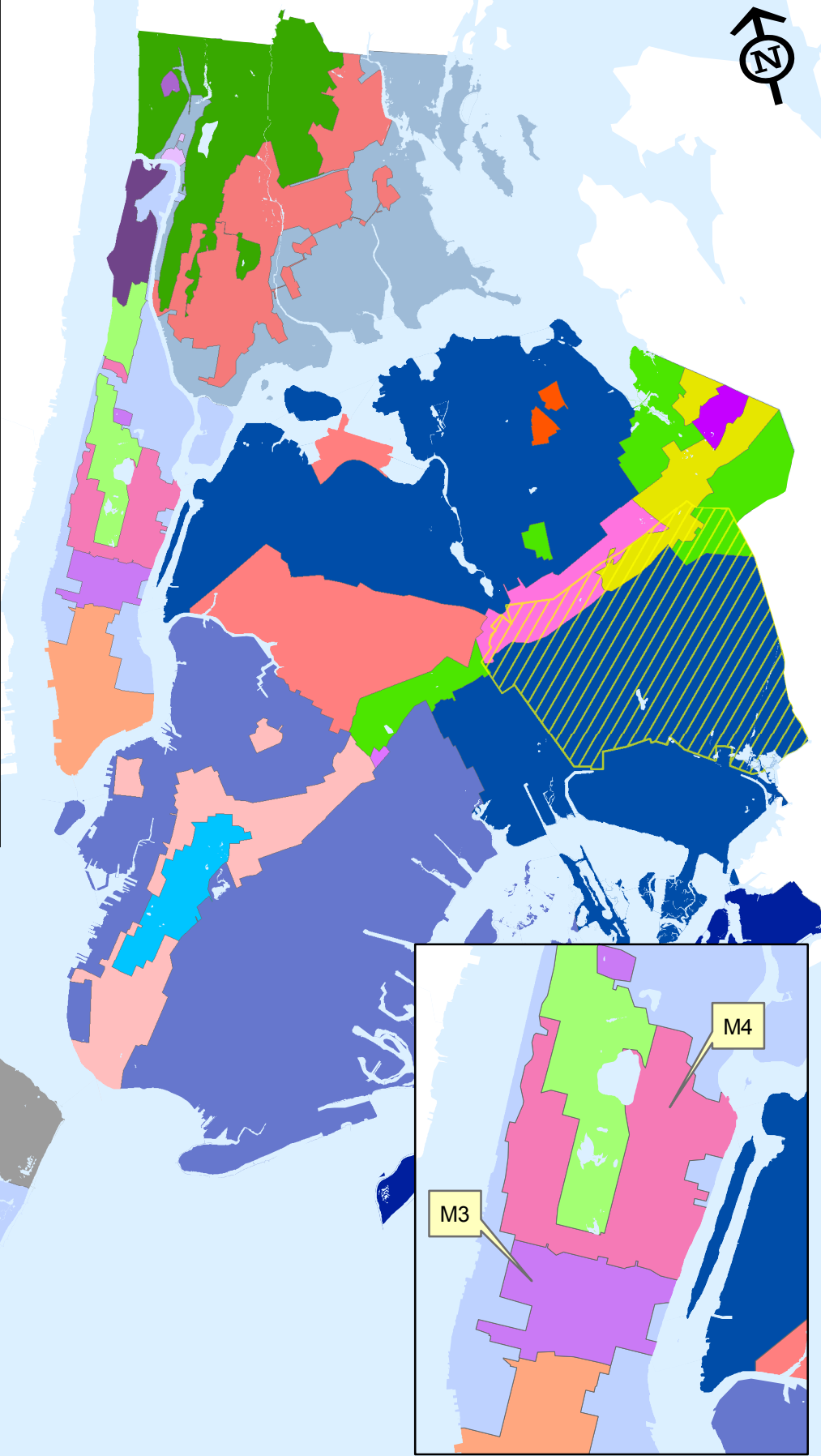
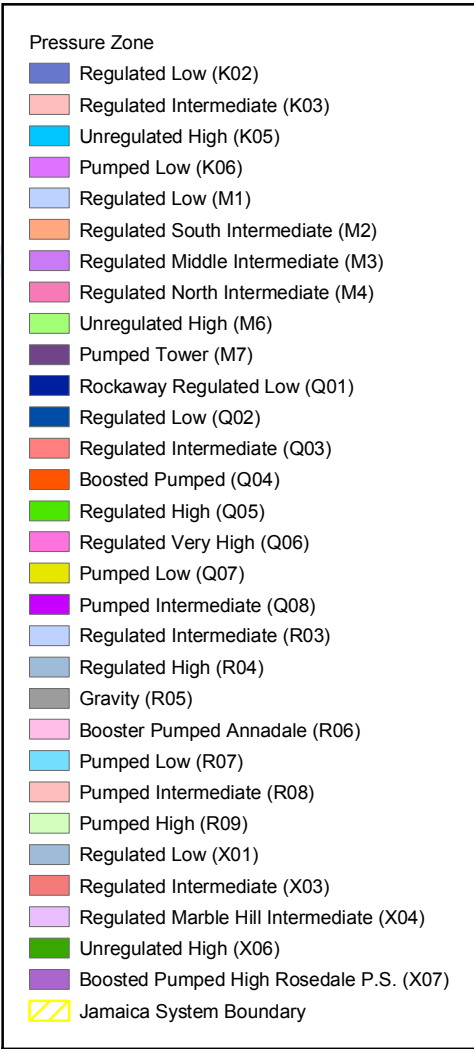

NEW YORK CITY DEPARTMENT OF ENVIRONMENTAL PROTECTION
PROPOSED SHAFT 33B TO CITY TUNNEL NO. 3
STAGE 2 - MANHATTAN LEG
PURPOSE AND NEED AND PROJECT OVERVIEW
PRESSURE ZONES

FIGURE 2-4

is conveyed through trunk mains so that adequate pressure is available to distribute the water greater distances or at higher elevations. Each pressure zone is typically served by several regulators. Water can also be provided to a pressure zone from an adjacent zone that is at higher pressure.

2.2.2 Need for Shaft 33B

One of the primary purposes for City Tunnel No. 3, which is currently being constructed in Manhattan, is to provide water delivery alternatives to City Tunnel No. 1, thereby adding redundancy and reliability to the City's water distribution. At the same time, City Tunnel No. 3 is also being designed and constructed to help address local supply issues, such as a lack of redundancy in the local network. One critical area that would be served by the Stage 2, Manhattan Leg of the new tunnel, via Shaft 33B, is the Middle Intermediate Pressure Zone (MIPZ). In addition, this leg of the tunnel is being designed so that redundant water supply capacity will also be provided for the adjacent water pressure zone, the Northern Intermediate Pressure Zone (NIPZ).

Water Supply Issues in MIPZ and NIPZ

The MIPZ is located in Midtown Manhattan, bounded roughly by Tenth Avenue to the west, the East River to the east, approximately 34th Street to the south, and approximately 54th Street to the north. This area is home to Manhattan's largest Central Business District as well as a dense residential neighborhood east of Third Avenue. Immediately to the north of the MIPZ, the NIPZ spans the width of Manhattan between 54th Street and approximately 102nd Street. The NIPZ is broadly defined by the northern portion of the Midtown Manhattan Central Business District and by the densely developed residential neighborhoods of the Upper East Side and Upper West Side. The boundaries of the pressure zones were not established by specific streets, but by the topography of the area.

With a total of more than 1 million employees and more than 500,000 residents¹, the MIPZ and NIPZ have very high water consumption rates in comparison to the rest of the City. According to NYCDEP estimates of the approximate water usage for different areas of the City, the average water consumption in the MIPZ is 30 million gallons per day (mgd) per square mile. This is approximately six times higher than water usage in the Bronx, the Borough with the second highest water usage per square mile.

The MIPZ is currently supplied by three shafts of Tunnel No. 1, all located west of Park Avenue, with approximately 48 mgd. The supply network provides sufficient pressure throughout most of the zone. However, the eastern portion of the MIPZ, east of Park Avenue, has few large mains crossing beneath Park Avenue and therefore is constrained in terms of redundancy and capacity. When regulators or the large trunk main serving this area are out of service, low water pressure is

¹ Source: U.S. Census Bureau; Census 2000, Summary File 1; 2000 Census Transportation Planning Package (CTTP) Part 2: Total Workers at Place of Work (Regardless of Residence), Table CTPP2 P-1.

experienced at buildings in the MIPZ. The presence of the Metro-North train tunnel beneath Park Avenue limits the ability to provide additional crosstown trunk mains. Pressure reliability is critical for such water supply needs as fire-fighting capabilities.

All water in the NIPZ is supplied from one shaft of City Tunnel No. 1 and three shafts of City Tunnel No. 3, Stage 1. Water consumption in the NIPZ is approximately 77 mgd. However, there are few trunk mains in the southeast portion of the zone, between E. 54th and E. 68th Streets.

Shaft 33B

The Manhattan Leg of City Tunnel No. 3, Stage 2 is intended to address the problems of water pressure reliability and supply in the northeastern portion of the MIPZ, while adding flexibility and redundancy for the southeastern portion of the NIPZ. As illustrated in Figure 2-3, the north leg of City Tunnel No. 3's Stage 2 Manhattan Leg will follow a crosstown route, from Shaft 26B in West Midtown near Tenth Avenue eastward to Shaft 32B at Second Avenue near the MIPZ's southern boundary, and continue north up the East Side to a terminus in northern East Midtown at Shaft 33B. This north leg is intended to convey water to the distribution system east of Park Avenue and in the MIPZ. Moreover, it is critical that this area is fed by a new shaft, so that there would be no service disruptions or dramatic changes in pressure in the MIPZ in the event of a planned or unplanned shutdown of City Tunnel No. 1, including when City Tunnel No. 1 is shut down for maintenance after City Tunnel No. 3 is on line. Shaft 33B would be one of two sources of water supply from City Tunnel No. 3 to the eastern section of the MIPZ; the other would be Shaft 32B. Having two sources of water supply to the pressure zone is important in terms of redundancy, to protect the water supply in the event that repairs must be made at one of the shafts. Shaft 33B would be the primary source of the water supply from City Tunnel No. 3 to the northeast portion of the MIPZ. It would be one of 10 water supply shafts along the Stage 2 Manhattan Leg, and is the final shaft to be sited.

Locating Shaft 33B in the northeastern portion of the MIPZ would improve water pressure reliability in the MIPZ. By providing two shafts in the MIPZ, it would also provide redundancy within the pressure zone in the event that the other shaft, Shaft 32B, must be taken out of service. Shaft 33B would similarly improve redundancy in the eastern section of the NIPZ, which would also have two shafts connected to City Tunnel No. 3 once Shaft 33B is complete. Finally, with Shaft 33B in place in this area, there would be no service disruptions or dramatic changes in pressure when City Tunnel No. 1 is taken off-line for maintenance upon completion of City Tunnel No. 3.

If Shaft 33B were not sited in the northeastern portion of the MIPZ, alternative water supply would have to be provided to the MIPZ without a new shaft. Without any new water distribution infrastructure, it would be difficult to maintain adequate pressure in the MIPZ once City Tunnel No. 1 is removed from service for rehabilitation. It would also be difficult to accommodate the high water demand in the densely developed MIPZ. In the event Shaft 33B could not be constructed in the area, lengthy new water mains would have to be laid from the two closest water supply shafts—at Second Avenue near E. 35th Street, and at York Avenue near E. 77th Street—to supply water to areas throughout the MIPZ and NIPZ. Thus, approximately 40 blocks

of water main construction would be required to ensure sufficient water supply capability in the Midtown and Upper East Side areas of Manhattan.

Inherent to NYCDEP's overarching goal of providing water supply redundancy on a City-wide basis is the commitment to provide redundancy at the local and neighborhood level. For this reason, NYCDEP strongly prefers that the Shaft 33B site have enough space to house two riser pipes to bring water from City Tunnel No. 3 to the surface. Having two risers is particularly important at Shaft 33B, which is at the terminus of the northern leg of Stage 2, Manhattan Leg, of City Tunnel No. 3. With two riser pipes, water can continue to flow through this segment of City Tunnel No. 3 and the shaft if one of those pipes or one of the connecting water mains is taken out of service for repair or maintenance. With a single riser, water would become stagnant in the portion of the Tunnel north of Shaft 32B near E. 35th Street during a shaft shutdown, necessitating lengthy and complex procedures to disinfect and reactivate this whole Tunnel segment once the riser is repaired. With two risers, regular maintenance can be performed more effectively on the valves and equipment at Shaft 33B; without two risers maintenance procedures would be more complicated and less effective. The other terminal shaft in Manhattan, at E. 4th Street, will also have two risers for the same reasons.

The two risers at Shaft 33B would feed two separate 48-inch water main connections that would bring the water to the Third Avenue trunk main for distribution throughout the MIPZ and NIPZ. One water main would connect to the Third Avenue trunk main in the MIPZ, and the other would connect in the NIPZ. Between the two connections, a new boundary valve would be installed in the Third Avenue trunk main. Having these two mains would allow Shaft 33B to serve both pressure zones, one of the critical goals for the project. It also provides additional redundancy, and, like the two risers, avoids the potential for stagnant water in the portion of City Tunnel No. 3 north of E. 35th Street in the event that one main must be shut down for maintenance and repair. Having two water main connections is critical for Shaft 33B, since Shaft 33B is a terminal shaft.

2.3 PROPOSED LOCATION FOR SHAFT 33B

2.3.1 Locational Requirements for Shaft 33B

As described above in Section 2.2, "Project Purpose and Need," the north leg of City Tunnel No. 3's Stage 2 Manhattan Leg will travel from Shaft 32B at Second Avenue near E. 35th Street to a terminus in East Midtown at Shaft 33B. While the specific location for this terminus depends on the suitability and feasibility of sites for Shaft 33B, there are certain locational requirements for the new shaft.

Shaft 33B is intended to address the issues of water pressure and water distribution in the portion of the MIPZ east of Park Avenue. To meet this need, the shaft also must be located east of Park Avenue. The new shaft would bring water from City Tunnel No. 3 to the primary trunk main for the eastern portions of the MIPZ and NIPZ, which runs beneath Third Avenue.

As also described above, Shaft 33B is intended to serve the northeastern portion of the MIPZ and the southern portion of the NIPZ. Two new water mains would run from the regulators at Shaft 33B to the Third Avenue trunk main, as described in more detail later in this Chapter. The two large trunk mains are necessary to provide reliable and abundant water supply for the MIPZ and NIPZ. Of the two new water mains that would connect Shaft 33B with the Third Avenue trunk main, one would supply water to the MIPZ and the other would supply water to the NIPZ. Therefore, it is preferable to locate Shaft 33B in the general area of the boundary between those two zones.

2.3.2 Review of Potential Sites

Construction of Shaft 33B would require a site of a certain size and configuration to accommodate the space required for construction. A minimum site width of 39 feet is required for excavation of the distribution chamber, which has a minimum width of 26 feet, plus a 5-foot-wide workspace on either side of the excavation, and additional room for minimal excavation support. This minimum width assumes the presence of bedrock close to the surface; for sites where bedrock is deeper, more substantial support (a cofferdam) would be constructed around the distribution chamber, adding to the width required on the site. A site length of about 175 to 200 feet is necessary to accommodate shaft construction, construction staging area, and to provide room for maneuverability of equipment (e.g., a crane). In addition, a certain amount of overhead clearance would be needed for the crane.

A site screening process was undertaken to identify possible Shaft Sites in the general area where Shaft 33B must be located to meet its intended purpose. As noted earlier, this is the general area within an acceptable distance from the boundary between the MIPZ and NIPZ at the Third Avenue trunk main. While Shaft 33B could be located at a greater distance from the connection point to the Third Avenue trunk main, the need to connect to that trunk main close to the boundary between the MIPZ and NIPZ would not change and therefore longer water main connections would be required. Given the greater disruption that would be required for these water main connections, NYCDEP restricted the review of available sites to those sites that are proximal to the northern portion of the MIPZ and the southern portion of the NIPZ.

During this process, NYCDEP identified underutilized properties between E. 46th and E. 62nd Streets east of Third Avenue and evaluated them for their feasibility and suitability to serve as a Shaft Site. Nineteen locations were identified and each of these sites was evaluated to determine whether construction of the shaft would be feasible at that location. Sites were determined to be infeasible if one of the following conditions applied:

- The site would require condemnation of active private property, other than surface parking lots or vacant lots.
- The site would require closing an entire street or avenue for construction of the shaft.
- The site configuration would not accommodate the required space needed for construction of the shaft (assuming the minimum width of 39 feet and length of 175 to 200 feet).

Based on the initial evaluation of each site, 15 sites were removed from further consideration for Shaft 33B. Insufficient site size was the most prevalent disqualifying factor in the screening of the 19 sites. A description of this preliminary site evaluation is provided in Appendix 1.

Four sites were considered to be potentially feasible locations for Shaft 33B—at E. 59th Street and First Avenue; E. 59th Street and Second Avenue; E. 61st Street between First and Second Avenue; and E. 54th Street and Second Avenue. For these four sites, a preliminary review of site characteristics and engineering and environmental considerations was conducted to identify a preferred Shaft Site for consideration in the EIS. Several factors were considered in conducting preliminary evaluations of these potential sites:

- City-owned sites are preferred to privately owned sites, because these sites reduce the complications and potential delay associated with acquiring private property.
- Sites with greater distance to the nearest residences would reduce potential disturbance during construction and improve constructability of the shaft.
- Sites larger than the minimum size would allow construction of a construction barrier during construction.
- Sites with regular shapes and access on more than one side would be more efficient for construction.
- Sites within mapped streets or sidewalks are preferred for the permanent placement of utilities.
- Sites that minimize disruption to existing utilities and minimize or avoid traffic lane closures are preferred.
- Sites where excavation can be completed before mid-2007 are preferred, so that excavated material can be removed through City Tunnel No. 3 instead of from Shaft 33B. City Tunnel No. 3 and its staging area at Shaft 26B will no longer be available for this use once the Tunnel is lined with concrete. At this time, based on the current Tunnel schedule, it appears that the Tunnel and Shaft 26B will not be available after July 2007.

As a result, a preferred Shaft Site and three feasible alternative sites were identified. These are described below and evaluated in this EIS.

2.3.3 Sites Evaluated in this EIS

This EIS analyzes the four remaining feasible potential Shaft Sites that would meet the purpose and need for the project, and the associated routes for water main connections from those sites to the Third Avenue trunk main. More information about the specific project elements proposed, including shaft components and the water main connections, is provided later in this Chapter in Section 2.4. The four potential sites and the potential water main connection routes from those sites are shown in Figures 2-5, 2-6, and 2-7 and described briefly below. The comparative advantages and disadvantages of these sites are discussed in Chapter 11, “Comparison of Alternatives.”

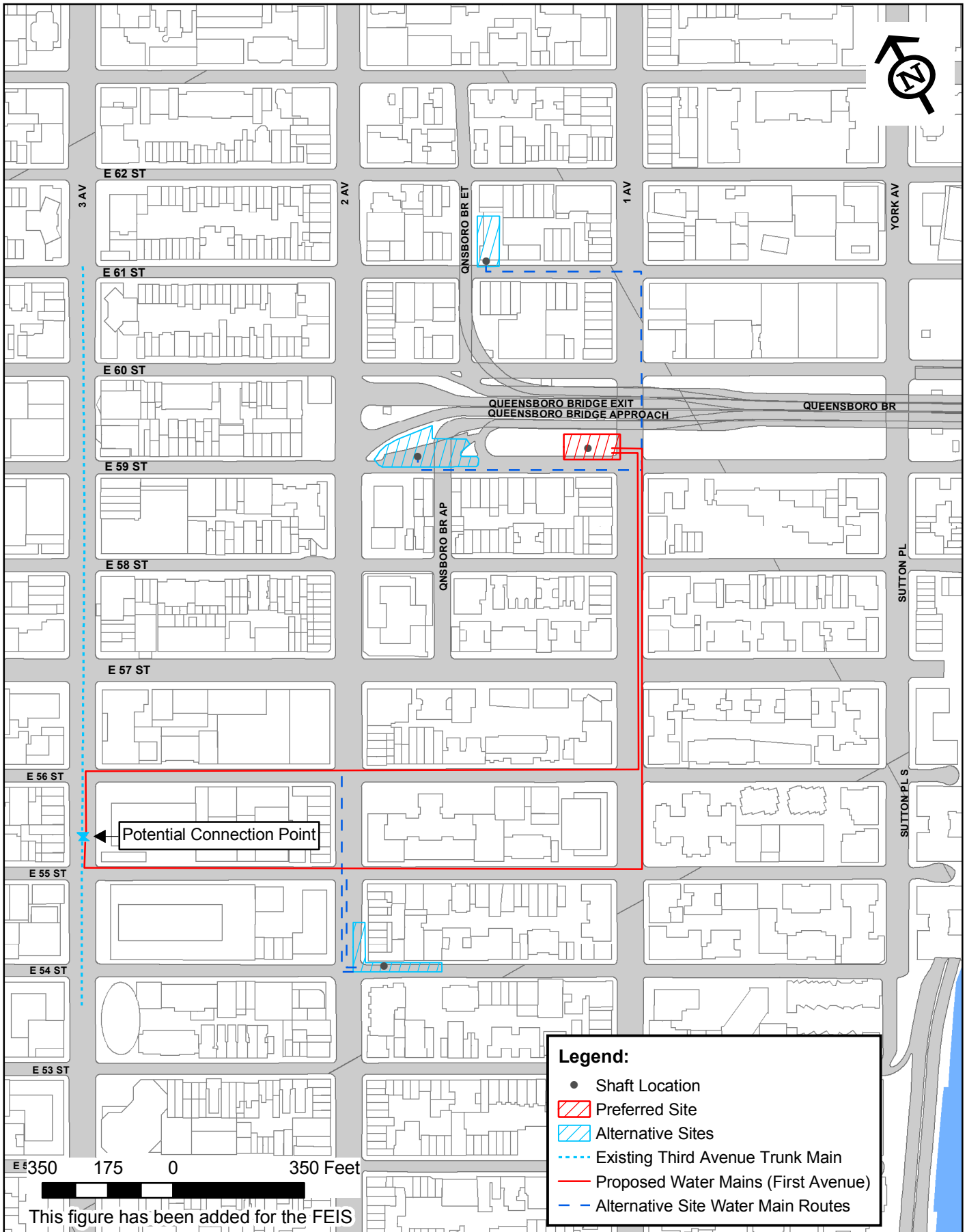

Map Document: (S:\Projects\2175158\GIS_Figures\Shaft_33B\GIS_Field_Work\Watermain_Connections\AKRF\1stAve.mxd)
1/10/2006 - 10:23 PM



**NEW YORK CITY DEPARTMENT OF ENVIRONMENTAL PROTECTION
PROPOSED SHAFT 33B TO CITY TUNNEL NO. 3
STAGE 2 - MANHATTAN LEG
PURPOSE AND NEED AND PROJECT OVERVIEW
ALTERNATIVE SITE LOCATIONS AND WATER MAIN ROUTES**

FIGURE 2-5

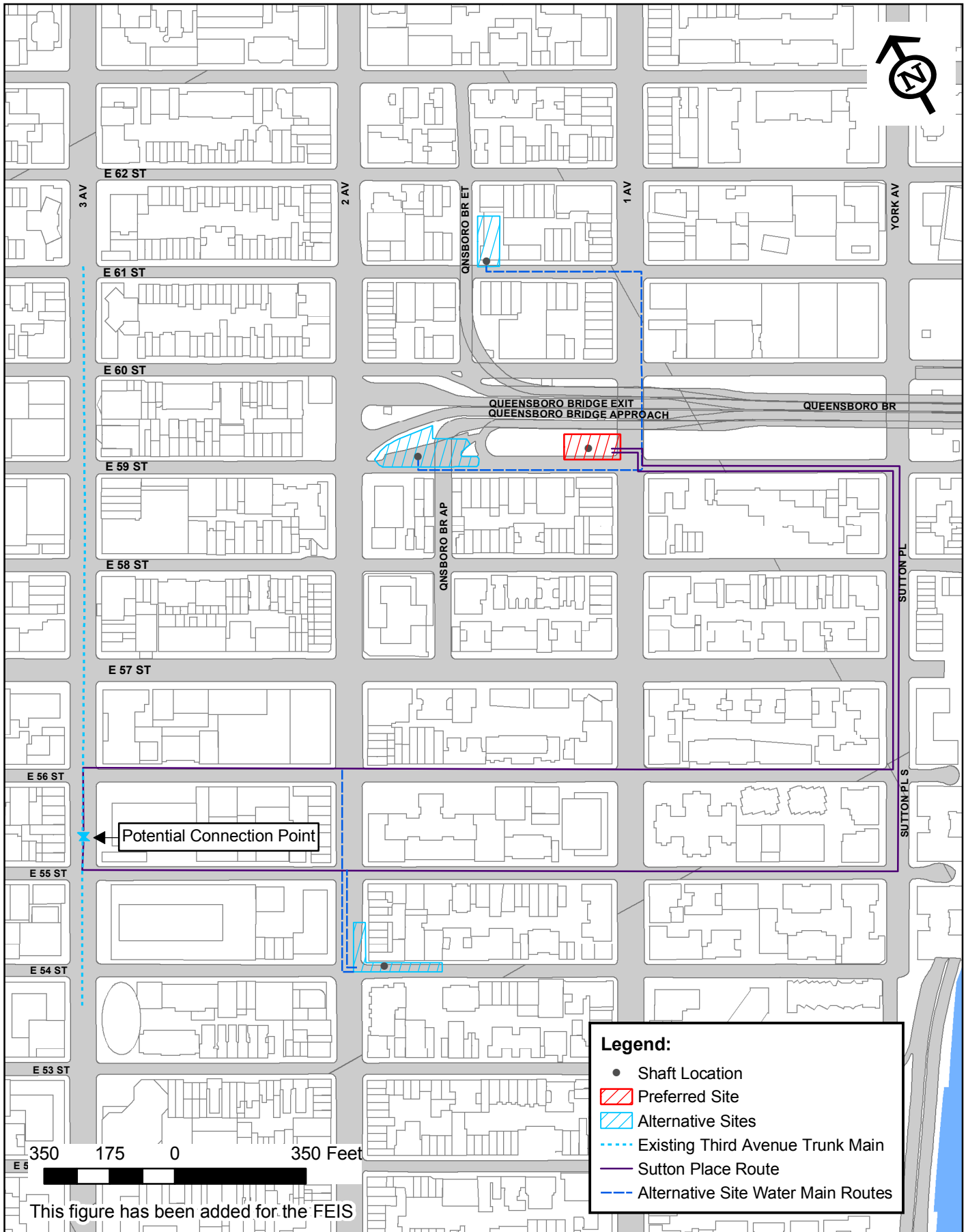

This figure has been added for the FEIS

Map Document: (S:\Projects\2175158\GIS_Figures\Sheet_33B\GIS_Field_Work\Watermain_Connections\AKRF\Sutton.mxd)
1/10/2006 - 1:14:37 PM



**NEW YORK CITY DEPARTMENT OF ENVIRONMENTAL PROTECTION
PROPOSED SHAFT 33B TO CITY TUNNEL NO. 3
STAGE 2 - MANHATTAN LEG
PURPOSE AND NEED AND PROJECT OVERVIEW
ALTERNATIVE SITE LOCATIONS AND WATER MAIN ROUTES**

FIGURE 2-6

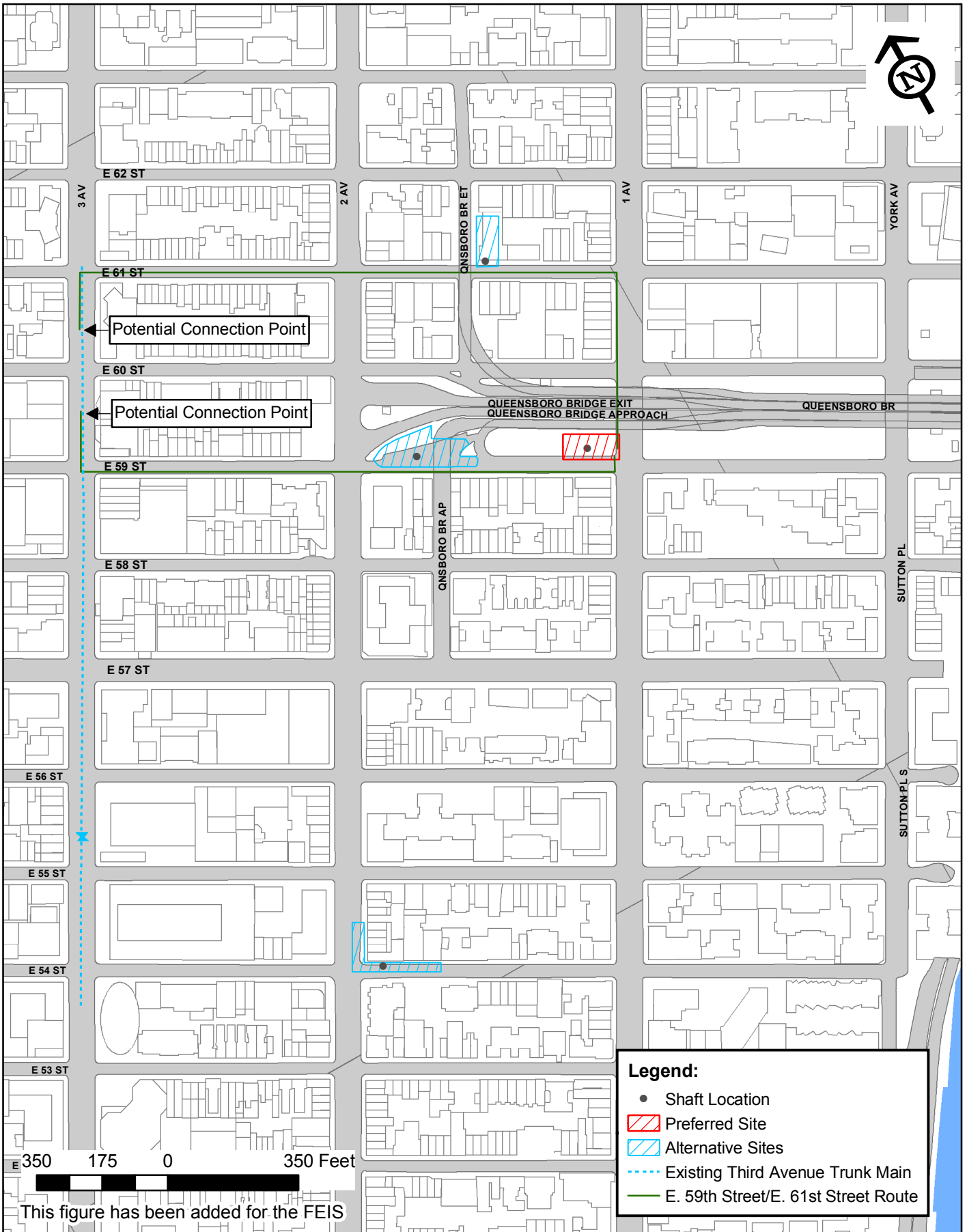

Map Document: (S:\Projects\2175158\GIS_Figures\Shaft_33B\EIS_Field_Work\Watermain_Connections\AKRF\59th-61st).mxd
1/10/2006 - 12:14:2 PM



**NEW YORK CITY DEPARTMENT OF ENVIRONMENTAL PROTECTION
PROPOSED SHAFT 33B TO CITY TUNNEL NO. 3
STAGE 2 - MANHATTAN LEG
PURPOSE AND NEED AND PROJECT OVERVIEW
ALTERNATIVE SITE LOCATIONS AND WATER MAIN ROUTES**

FIGURE 2-7

Preferred Shaft Site and Water Main Connections

This site was identified as the preferred Shaft Site based on a comparative review of the potential advantages and disadvantages of the construction of Shaft 33B at each feasible location (for more information, see Chapter 11, “Comparison of Alternatives”). The preferred Shaft 33B Site is located adjacent to the Queensboro Bridge (Bridge) approach structure at the northwest corner of E. 59th Street and First Avenue (Block 1434 Lot 1). The entire preferred Shaft 33B Site is City-owned and is mapped street. The site is under the jurisdiction of the New York City Department of Transportation (NYCDOT), and used by NYCDOT for Bridge-related activities.

This site is large enough for the construction and operation of two risers. In addition, the preferred Shaft Site has physical configuration that allows efficient construction, with a regular shape and street access on two sides. Two possible site layouts during construction were considered at the preferred Shaft Site—the “base configuration” and the “alternate site configuration.” The alternate site configuration, 8,970 square feet in size, is slightly larger than the 7,400-square-foot base configuration and provides an analysis of a reasonable worst-case construction scenario that would occur if construction had to extend into the streetbeds of E. 59th Street and First Avenue to provide a more efficient construction equipment layout. At this time, NYCDEP anticipates that construction would occur using the base configuration; the alternate site configuration could be used by the contractor only with NYCDEP’s approval.

Under either site configuration, during 23 months of construction in Stages 2 and 3, the construction area at the preferred Shaft Site would expand to include an 1,800-square-foot portion of an adjacent publicly owned parcel commonly referred to as “14 Honey Locusts Park” or “Gateway Plaza.” The area is under the jurisdiction of NYCDOT and has historically been used as a shared resource, by NYCDOT as a Bridge access area for parking and maintenance and rehabilitation activities, and by the public who generally use it for open space activities. Use of this area for construction of the shaft would require removal of two honey locust trees.

The specific route for the water main connection from the preferred Shaft Site to the Third Avenue trunk main has not yet been determined; the route of the water main connections would be selected by NYCDEP after Shaft 33B is sited. The New York City Department of Design and Construction (NYCDDC) would then design and construct the water mains. NYCDDC is the City agency charged with design and construction of many of the City-sponsored construction projects occurring within City streets and sidewalks. This allows coordination of the various projects, so that disturbance to the street can be minimized. For more information on construction of water main connections, see Section 5.1 of this EIS.

Ideally, the two water main connections from Shaft 33B would connect to the existing trunk main beneath Third Avenue in the vicinity of E. 55th to E. 56th Streets, at the approximate boundary between the MIPZ and the NIPZ. However, NYCDEP is considering the potential to connect into the Third Avenue trunk main as far north as E. 59th Street for the MIPZ connection. As there are many potential possible water main connection routes, the EIS analyses consider a reasonable worst-case route and two additional representative water main connection routes to identify the types of impacts that could occur from water main construction using any likely route. These three water main connection routes are: (1) a First Avenue route, traveling down

First Avenue and then over to Third Avenue via E. 55th and E. 56th Streets (“the reasonable worst-case route”); (2) a Sutton Place route, traveling over to Sutton Place on E. 59th Street, down Sutton Place, and then over to Third Avenue via E. 55th and E. 56th Streets; and (3) an E. 59th Street/E. 61st Street route, in which one water main would travel from the preferred Shaft Site to Third Avenue via E. 59th Street, and the other would travel up First Avenue two blocks and then over to Third Avenue via E. 61st Street. The potential water main routes are discussed in more detail in Chapter 5, “Water Main Connections,” Section 5.1, “Project Description.”

Alternative Sites and Water Main Connections

In addition to the preferred Shaft Site, this EIS also analyzes three feasible alternative Shaft Sites, at E. 59th Street and Second Avenue, at E. 61st Street between First and Second Avenues, and at E. 54th Street and Second Avenue.

E. 59th Street/Second Avenue Shaft Site

The E. 59th Street/Second Avenue Shaft Site is located in a portion of the street and sidewalk on the northern side of E. 59th Street east of Second Avenue. The approximately 15,000-square-foot site is City-owned and includes an area adjacent to the Queensboro Bridge that is mapped street, as well as the northern part of the E. 59th Street roadbed at the western end of the block, close to Second Avenue. A single eastbound lane would be maintained on E. 59th Street alongside the construction site, which is the same as in the existing condition.

Construction at this alternative Shaft Site would be constrained by the site’s irregular shape and its location partially beneath a Queensboro Bridge access ramp. Moreover, due to the site configuration and the presence of utilities immediate to the shaft footprint, the site is not large enough to accommodate two risers, a critical NYCDEP goal for Shaft 33B. In addition, a sensitive Con Edison oil-o-static line and its associated chamber would need to be relocated at this site before construction of the shaft can begin. The process of relocating this oil-o-static line, including planning and implementation, may take a total of 10 to 12 months. Delays to the construction schedule might mean that rock excavated from this alternative Shaft Site cannot be removed through City Tunnel No. 3.

Similar to the preferred Shaft Site, water main connections from this alternative Shaft Site could follow many possible routes to the Third Avenue trunk main. For purposes of the EIS, it was assumed that the same potential routes would be followed as for the preferred Shaft Site since it is in close proximity to the preferred site. The water main connections from this alternative Shaft Site would extend east on E. 59th Street from the alternative Shaft Site to First Avenue, where they would join the First Avenue and Sutton Place water main connection routes described above for the preferred Shaft Site. For the E. 59th Street/E. 61st Street route from this alternative Shaft Site, it is assumed that the water main connection for the MIPZ would head west on E. 59th Street and the connection for the NIPZ would head east down E. 59th Street to First Avenue, where it would join the route described above for the preferred Shaft Site. As discussed in further detail in Chapter 6, “E. 59th Street/Second Avenue Shaft Site,” for any of these potential water main routes from the E. 59th Street/Second Avenue Shaft Site, to maintain traffic flow on E. 59th Street while construction of the water mains is occurring in the southern portion of the streetbed,

eastbound traffic from Second Avenue could be temporarily routed to the north side of E. 59th Street, passing beneath the northern arch of the Queensboro Bridge entrance ramp that crosses E. 59th Street. This northern detour would therefore pass through the small 1,100-square-foot traffic island immediately east of the elevated Bridge ramp, requiring removal of some or all of the three trees in that traffic island.

E. 61st Street Shaft Site

This site is located on the north side of E. 61st Street, between First and Second Avenues immediately east of the elevated exit ramp from the upper level of the Queensboro Bridge (Block 1436 Lot 13). The 9,000-square-foot vacant parcel is owned by the Archdiocese of New York. This site is large enough to accommodate two risers in the shaft and is regular in shape, which would facilitate construction. However, the Archdiocese is planning to develop this site with a residential structure, and has not been receptive to NYCDEP's acquisition or use of the site. The lengthy site acquisition process could result in construction delays that might mean that rock excavated from the shaft and chambers cannot be removed through City Tunnel No. 3.

Similar to the preferred Shaft Site, water main connections from this alternative Shaft Site could follow many possible routes to the Third Avenue trunk main. For purposes of the EIS, it was assumed that the same potential routes would be followed as for the preferred Shaft Site. The water main connections from the E. 61st Street Shaft Site would head east on E. 61st Street to First Avenue, and head south on First Avenue to E. 59th Street, after which they would follow the same routes as assessed for the preferred Shaft Site. For the E. 59th Street/E. 61st Street route from this alternative Shaft Site, it is assumed that the water main connection for the NIPZ would extend west on E. 61st Street to Third Avenue and the connection for the MIPZ would head east on E. 61st Street to First Avenue, then south on First Avenue to E. 59th Street, where it would join the route described above for the preferred Shaft Site (west on E. 59th Street to Third Avenue).

E. 54th Street/Second Avenue Shaft Site

The E. 54th Street Shaft Site is an approximately 8,500-square-foot, “L”-shaped area located entirely in the street and sidewalk of E. 54th Street and of Second Avenue, at the northeast corner of that intersection. This site is located completely within City property. Construction at this site would require several lane closures for the duration of the construction period, including two lanes (one parking lane and one traffic lane) on Second Avenue and two of the three lanes (one parking lane and one traffic lane) on E. 54th Street. In addition, it would require the use of some of the sidewalk on the south side of E. 54th Street as a vehicle lane, to keep the street open to traffic. To maintain a sidewalk along the southern side of the street adjacent to the shifted vehicle lane, this alternative Shaft Site might require a temporary easement, approximately six feet wide, across private property through a landscaped area that faces E. 54th Street near Second Avenue. Limited utilities within the street bed would need to be relocated for shaft construction at this site.

The site's small size and L-shaped configuration would present several disadvantages. First, the site is not large enough to accommodate two risers, a critical NYCDEP goal for Shaft 33B. Second, the site has a non-contiguous configuration, since it would be divided by two different

areas that must be kept free for potential emergency access by the Fire Department of New York (FDNY) as well as for an access point for a private parking garage, which would complicate the constructability of the site. In addition, an enclosed sidewalk café area built as an extension to a restaurant would have to be removed before construction can begin. Further, because of this site's proximity to residential buildings, blasting cannot be used for excavation of the distribution chamber or upper portion of the shaft. This excavation would be conducted using alternative techniques, such as hydraulic splitting, which are much slower than blasting. The resulting delays to the schedule could mean that rock excavated from the shaft and chambers could not be removed through City Tunnel No. 3.

Water main connections from this alternative Shaft Site could follow several possible routes to the Third Avenue trunk main. For purposes of the EIS, it was assumed that both water main connections would head north from the alternative Shaft Site on Second Avenue, and then west on E. 55th and E. 56th Streets to Third Avenue. Using this or other possible routes, the distance to the Third Avenue trunk main would be substantially less from the E. 54th Street/Second Avenue Shaft Site than from the preferred Shaft Site.

Other Alternatives

In addition, this EIS also considers two other alternatives: a Water Main Only Alternative, in which no new Shaft 33B is provided, but new water main connections extending 42 blocks from the two nearest water tunnel shafts—at Second Avenue near E. 35th Street, and at York Avenue near E. 77th Street—are provided to supply water throughout the MIPZ and NIPZ; and a No Action Alternative, in which no construction of a new water shaft to City Tunnel No. 3 or any water main connections occurs. These alternatives are described and analyzed in Chapter 9, "Water Main Only Alternative," and Chapter 10, "No Action Alternative," respectively.

As described in Chapters 9 and 10, neither the Water Main Only Alternative nor the No Action Alternative would meet the purpose and need for the project. The Water Main Only Alternative would not provide the critical redundancy needed for the MIPZ, since no additional distribution from City Tunnel No. 3 would be provided. Moreover, construction of a 42-block-long water main would be likely to result in a substantial amount of street and utility work and consequent disruption during the construction period. NYCDEP would not pursue the No Action Alternative because it would leave a large and densely populated area of Manhattan without sufficient water distribution mechanisms when City Tunnel No. 1 is taken off-line for inspection and rehabilitation.

2.4 OVERVIEW OF SHAFT SITE AND WATER MAIN COMPONENTS

2.4.1 Shaft

The Shaft 33B structure would consist of the same basic components regardless of its location. Shaft 33B would consist of a vertical cylindrical hole approximately 450 feet deep, constructed primarily in bedrock and encased in concrete. The shaft would be about 25 feet in diameter at the

surface and would taper slightly as the depth increases. Within the shaft, two 48-inch-diameter steel pipes encased in concrete (“risers”) would bring water from City Tunnel No. 3 up to the neighborhood water distribution system. As noted above, at two of the alternative Shaft Sites—E. 59th Street/Second Avenue and E. 54th Street/Second Avenue—Shaft 33B could accommodate only one riser pipe.

Within the shaft, the risers would pass through two separate chambers. The first, the riser valve chamber, would house valves and actuators (mechanical devices used to open and close the valves) that could be used to shut down the risers for maintenance or repairs. This chamber would be located approximately 150 to 200 feet below ground surface. The second chamber, the distribution chamber, would be above the valve chamber and approximately 3 feet below the surface. This 25-foot-deep chamber would be approximately 60 feet long and 30 feet wide, and would house the connections between the risers and the shaft’s water main connections. Above the shaft, two ground-level hatchways, each approximately 3 feet by 5 feet, would provide access to these underground chambers. Figure 2-8 illustrates the components of the shaft.

In addition, an above-ground 10-foot-high air vent, 14 inches in diameter, would be located permanently on the site or adjacent sidewalk to provide air into the shaft for maintenance workers (Figure 2-9). Up to two standard 3-foot-high hydrants, 6 inches in diameter, would be provided on the site or adjacent sidewalk for use when the piping is activated. Air release hydrants would be used initially to activate the piping (discussed below in Section 2.6) and then, approximately once a year, to reactive the piping following routine valve and pipe testing. During the activation and reactivation sequences, the hydrants would be used to release the air in the pipes while they are filling with water. After the air is fully released from the pipes, water is then released so the pipes can be flushed. In addition, when air relief hydrants are located near the sidewalk, they can also be used by the FDNY for firefighting purposes.

2.4.2 Water Main Connections

Two 48-inch-diameter water mains would extend underground from the distribution chamber at Shaft 33B to provide a connection between the risers in Shaft 33B and the existing water distribution system. These water mains would run from the Shaft Site to the 30-inch Third Avenue trunk main, which is the primary distribution main for all water in the portions of the MIPZ and NIPZ east of Park Avenue. A new boundary valve would be installed on the Third Avenue main, so that one of the new mains would provide water to the MIPZ south of the boundary valve, and the other would supply the NIPZ north of the valve.

Close to Shaft 33B the new water main connections would pass through several below-grade chambers housing equipment that regulates and monitors the flow to the water main connections that would extend from the shaft. These include regulator, valve, and venturi chambers.

Each 48-inch water main would pass through a separate regulator. As described earlier, regulators control the pressure of water entering a particular pressure zone, reducing the high pressure that naturally flows from the water supply system down to one consistent pressure throughout the pressure zone. Since the two water mains from Shaft 33B would serve two

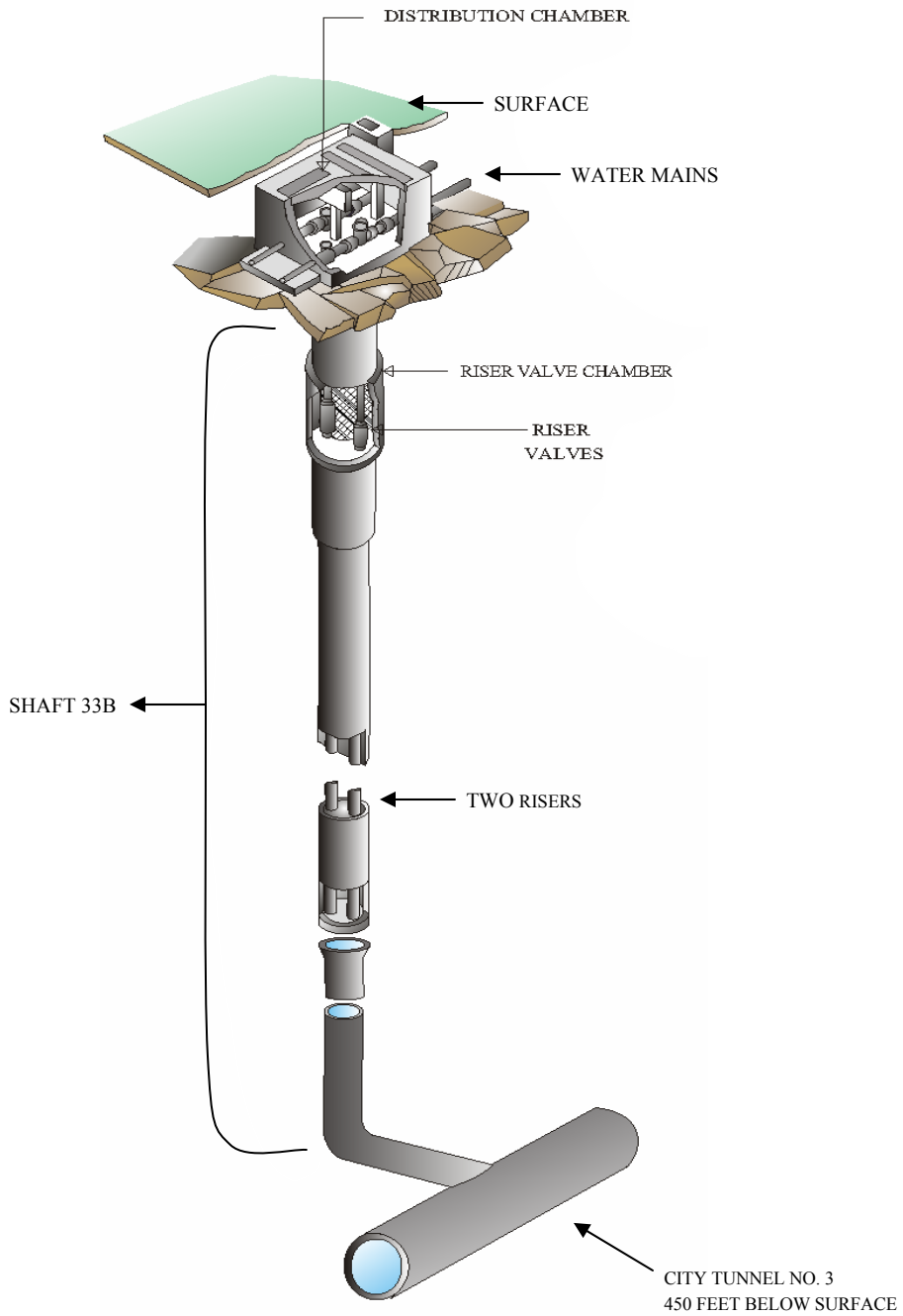

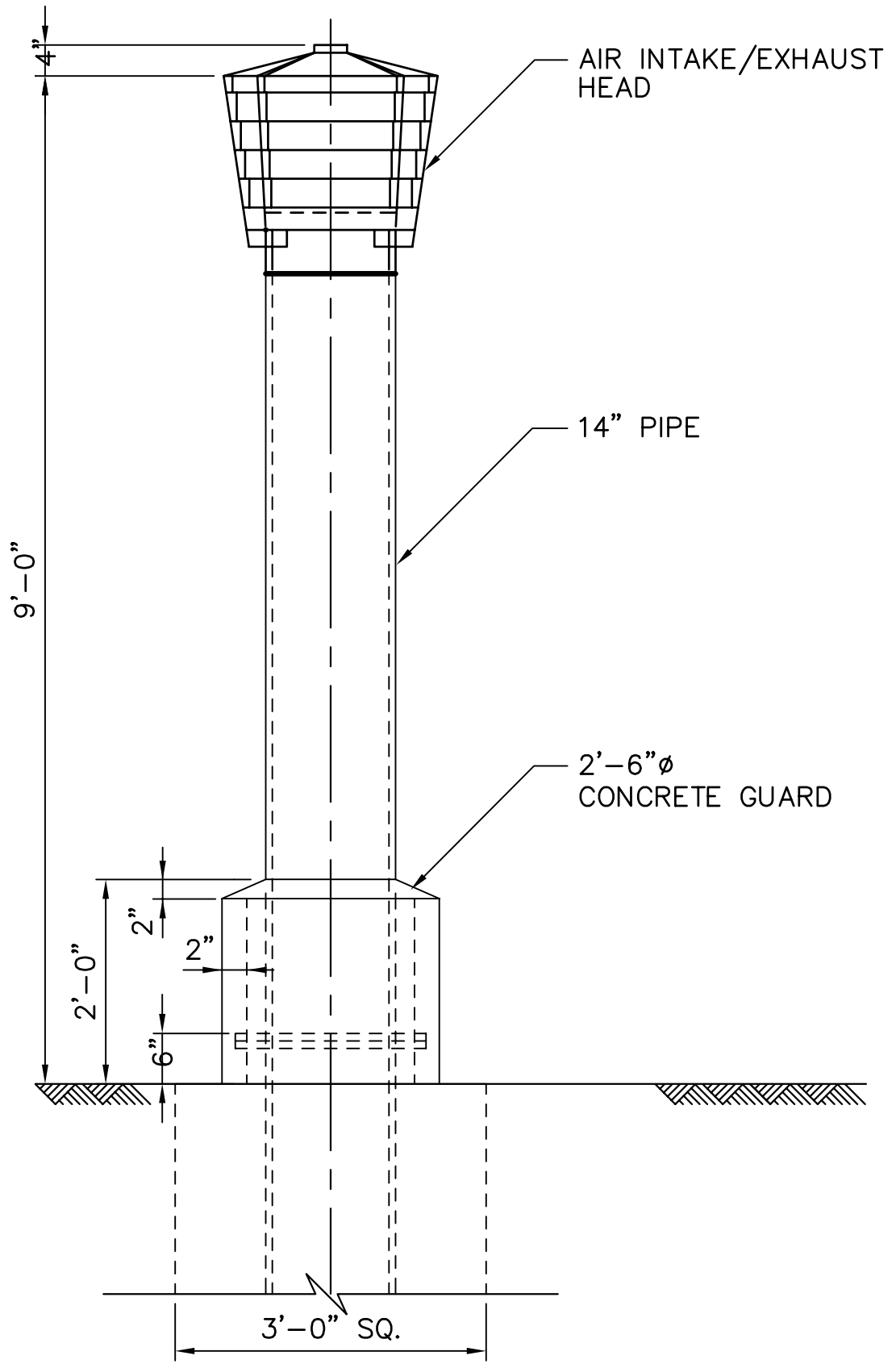

NOT TO SCALE



NEW YORK CITY DEPARTMENT OF ENVIRONMENTAL PROTECTION
 PROPOSED SHAFT 33B TO CITY TUNNEL NO. 3
 STAGE 2- MANHATTAN LEG
 PURPOSE AND NEED AND PROJECT OVERVIEW
 AIR VENT

FIGURE 2-9

CHAPTER 2
PURPOSE AND NEED AND PROJECT OVERVIEW

different pressure zones, each must be regulated separately. Regulators should be located in close proximity to the shaft, to avoid having water flowing beneath the street in unregulated mains. Having regulators close to shafts makes them easier to monitor. The regulator chambers for the water main connections from the Shaft 33B Site would be either on the site or close to the site, depending on which site is selected, and would be approximately 8 feet by 16 feet and 9 feet deep.

Adjacent to each regulator chamber, a valve chamber would contain a valve that could be used if NYCDEP wished to bypass the regulator and have unregulated flow enter the local distribution system. The valve chambers would be similar in size to the regulator chambers.

Each water main would also pass through a venturi chamber, an underground chamber approximately 12 feet by 16 feet and 10 feet deep. The venturi chambers would contain water meters that measure the flow speed of water in the pipe, to identify the volume flow rate in the pipe. This information would be transmitted via a pressure line to the shaft distribution chamber, where it could be monitored by NYCDEP personnel. For this reason, the venturi chambers should be located close to Shaft 33B. The underground water main chambers would be accessible for maintenance via manholes in the sidewalk.

During project planning, NYCDEP also considered alternatives to the two 48-inch water mains that would lessen the amount of street disruption required during construction. These included using one 60-inch water main, using two 48-inch mains laid one over the other rather than beside each other, or using two smaller mains.

Use of one large 60-inch main instead of two 48-inch mains would eliminate the benefit of redundancy at Shaft 33B described earlier in this Chapter. With only one water main, if the main must be shut down for maintenance and repair, this portion of the MIPZ would have limited sources of water supply, particularly if City Tunnel No. 1 is not operating. In addition, during the shutdown water in the portion of City Tunnel No. 3 north of E. 35th Street would be stagnant, necessitating lengthy and complex procedures to disinfect and reactivate this entire Tunnel segment once the main is repaired. For these reasons, having two water main connections at Shaft 33B is critical.

While feasible, placing one pipe above another, rather than side by side, would result in difficulties in accessing the lower pipe for repairs. Using two smaller mains (for example, 36-inch mains) to reduce the disturbance to the street during installation of the mains is also feasible, but NYCDEP prefers to use larger water mains to supply water to the MIPZ and NIPZ, to better meet the goals of the project. This EIS analyzes the use of two 48-inch mains laid side by side on avenues, since this is the reasonable worst-case scenario in terms of environmental impacts, with respect to the diameter of the pipes and their layout. The final design and configuration of the water mains would be determined at a later date, as discussed below in subsection 2.5.2.

2.5 DESCRIPTION OF CONSTRUCTION ACTIVITY

2.5.1 Shaft Site Construction

Overview

The preferred Shaft Site and each alternative Shaft Site would each face different construction issues, and construction activities would vary from site to site. In general, however, most activities would be similar at all four sites. Those activities are outlined in this Section. Additional information on specific construction issues at the preferred Shaft Site is provided in Section 4.1, “Project Description,” of Chapter 4, “Preferred Shaft Site.” Similarly, information on specific construction issues for the alternative Shaft Sites is provided in the “Project Description” Sections in Chapters 6, 7, and 8.

Construction of Shaft 33B would be conducted in four stages. During the first three stages, the shaft and its valve and distribution chambers would be excavated and the riser pipes would be installed. Following Stage 3, the Shaft Site would be secured and inactive for an 8-month period while specialized equipment is ordered. The fourth stage of construction would consist of equipment installation in the shaft and chambers and construction of regulator and valve chambers. Separate from the shaft construction, water main connections would likely occur simultaneously with the other construction stages and would consist of installation of water main connections between Shaft 33B and the Third Avenue trunk main.

Before construction begins, the site would be enclosed with secure concrete barriers and fencing. In the initial phase, a 20-foot-high construction barrier would be erected (however, at the E. 54th Street/Second Avenue Shaft Site, this barrier would be 10 feet high). Throughout the construction process, 24-hour security would be provided at the Shaft Site.

During construction, the Shaft Site would be occupied by construction trailers, storage containers, and other construction equipment throughout the construction period. Some pieces of equipment would be required throughout the entire construction period, while others would be needed only for a particular stage.

At any of the Shaft Sites, NYCDEP will require several control measures to ensure that construction at the Shaft 33B Site is conducted in a manner protective of the local air quality. NYCDEP will require the contractor for Shaft 33B to reduce particulate matter emissions to the extent practicable by employing relatively new equipment (model years 2003 and newer), installing emissions controls on diesel equipment greater than 50 horsepower (hp), such as diesel particulate filters (DPFs) or diesel oxidation catalysts (DOCs), and using alternate means of powering the equipment, such as electricity, where possible. For diesel equipment greater than 50 hp in size that will not likely be able to implement DPFs, DOCs will be required. In addition, the water main connection construction activities that would be contracted by NYCDDC would be subject to New York City Local Law 77, which will require the use of Best Available

CHAPTER 2
PURPOSE AND NEED AND PROJECT OVERVIEW

Technology (BAT) for equipment at that time.² Based on discussions with NYCDDC, NYCDEP identified for this EIS the diesel equipment likely to be used during construction of the water mains and which of that equipment will require DPFs. The air quality analyses for the Shaft Sites and water main connections construction activities accounted for these future emission control requirements. NYCDEP will also require emission controls for the ventilated enclosure for concrete trucks. Additional information is provided in Chapter 3, “Impact Methodologies,” Section 3.11 “Air Quality,” along with the relevant air quality sections for the preferred Shaft Site, alternative Shaft Sites, and water main connections.

As noted earlier, City Tunnel No. 3, Stage 2 Manhattan Leg is currently under construction. Construction work is being staged from a Shaft Site on Tenth Avenue in West Midtown, Shaft 26B. If Shaft 33B is constructed at the preferred Shaft Site, it is currently anticipated that excavation would be completed prior to completion of City Tunnel No. 3, so that excavated materials from construction of Shaft 33B could be removed from the bottom of the shaft into the Tunnel and transported to Shaft 26B, where they would be removed via trucks. In this case, excavation would be conducted from the bottom of the shaft upward, using the “raise bore” method of excavation discussed below. However, City Tunnel No. 3 and its staging area at Shaft 26B will no longer be available for this use once the concrete lining is installed in the Tunnel. Based on the current Tunnel schedule, the Tunnel will no longer be available for this use after July 2007. As described later in this Chapter, work at any of the alternative Shaft Sites could potentially require more time than at the preferred Shaft Site, so that excavation would occur once the Tunnel is no longer available for removal of excavated materials. Therefore, excavation at the alternative Shaft Sites may have to be conducted from the surface downward (“surface excavation”) rather than from the bottom of the shaft.

It is anticipated that construction at the Shaft Site would be conducted in two shifts, from 7 a.m. to 3 p.m. and from 3 p.m. to 11 p.m. The majority of the heavy work would likely occur during the first shift. If the raise bore technique is used, a third (night) shift would occur during a three-month period in Stage 2 when underground raise-bore excavation would occur, which would require limited surface activity to monitor the raise-bore machine, as discussed below. An estimated 10 to 15 workers would work at the Site per shift during the busiest stages. If the raise bore technique is used, most of the work would occur within the shaft or its chambers; if the surface excavation technique is used, more activity would occur at the surface throughout the construction period.

During a typical day, one to three total trucks would arrive at and depart from the site, bringing deliveries and taking away debris. Using the raise bore technique, after the initial excavation of soil in Stage 1 and creation of the pilot hole in Stage 2 (discussed below), excavated rock would

² New York City Administrative Code § 24-163.3, adopted December 22, 2003, also known as Local Law 77, requires that any diesel-powered nonroad engine with a power output of 50 hp or greater that is owned by, operated by or on behalf of, or leased by a City agency shall be powered by ultra low sulfur diesel fuel and utilize the best available technology (BAT) for reducing the emission of pollutants, primarily particulate matter and secondarily nitrogen oxides. NYCDEP is charged with defining and periodically updating the definition of BAT.

be removed from the shaft through City Tunnel No. 3 rather than at the Shaft 33B Site. Based on preliminary engineering estimates, the maximum daily trucking activity would involve a maximum of 30 truck trips. This would occur during Stage 3 and would be due primarily to the concrete-pouring operations during that stage. Concrete trucks would pull into the site into a ventilated enclosed structure. Concrete trucks would be rinsed and the resulting discharge would be passed through a sediment trap prior to entering the catch basin. Using the surface excavation technique, an additional 5 to 10 trucks per day would be anticipated during Stage 2, when rock is being removed from the alternative Shaft Site. At any of the Shaft Sites, using either the raise bore or surface excavation techniques, NYCDEP would provide funding for as many traffic enforcement agents (TEAs) at the Shaft Site during construction as appropriate to facilitate vehicular and pedestrian flow. NYCDEP will continue its coordination with NYCDOT regarding the need for additional TEAs.

The work anticipated during the four stages of construction activity at the preferred Shaft Site or alternative Shaft Sites is described below and summarized in Table 2-1. Work during the fifth stage, water main construction, is described in Section 2.5.2 below. Additional information on specific construction issues at the preferred Shaft Site is provided in Section 4.1, “Project Description,” in Chapter 4, “Preferred Shaft Site.” Similarly, information on specific construction issues for the alternative Shaft Sites is provided in Section 6.1 for the E. 59th Street/Second Avenue Shaft Site, Section 7.1 for the E. 61st Street Shaft Site, and Section 8.1 for the E. 54th Street/Second Avenue Shaft Site.

Construction Stages

Stage 1

Stage 1 would include site preparation work, equipment mobilization, and excavation of the soil above bedrock at the location of the shaft. During this stage, the contractor would procure “long-lead items” (i.e., project materials that require time to order or fabricate, such as the riser pipes). Any necessary water and sewer connections, permits, and power connections would be obtained. On-site construction trailers and storage containers would be established.

During this stage, survey measurements would be conducted at locations near the Shaft Site to establish baseline elevations that would be used to confirm that construction activities in later stages are not causing any ground settlement in the area. In addition, crack gauges may also be installed on certain nearby structures for use later in the construction.

Stage 1 would include preliminary excavation of the soil at the top of the shaft and distribution chamber, down to bedrock. This soil would be excavated using traditional soil excavation techniques, such as use of an excavator to remove the soil and installation of steel beams and sheeting to support the sides of the excavated area. As the depth of the excavation increases, a crane with a clamshell attachment may be used in lieu of the excavator. At the E. 54th Street/Second Avenue Shaft Site, bedrock is very close to the surface, so excavation support would not be necessary. The excavated material would be removed from the site using dump trucks. Sump pumps or other measures would be used as needed to maintain dry conditions in the excavated area. The excavation would be completed once bedrock is reached.

CHAPTER 2
PURPOSE AND NEED AND PROJECT OVERVIEW

Table 2-1
Shaft Construction Stages

Stage	Raise Bore Technique		Surface Excavation Technique	
	Activity	Major Equipment	Activity	Major Equipment
SHAFT AND DISTRIBUTION CHAMBER				
1	Sidewalk and asphalt pavement demolition; initial excavation, installation of excavation support (except at E. 54 th Street/Second Avenue Site)	On-site: Backhoe, jackhammers, pile drilling rig, excavator, telescoping crane, compressor, front-end loader Trucks: Dump trucks, flatbed trucks	Same as for raise bore	Same as for raise bore
2A	Drill pilot hole, excavate shaft with raise bore	On-site: Derrick crane, raise bore machine, front-end loader Trucks: Dump trucks, flatbed trucks	E. 59 th Street/Second Avenue and E. 61 st Street Sites: Excavate distribution chamber by blasting E. 54 th Street/Second Avenue Site: Excavate distribution chamber by hydraulic splitting and blasting	On-site: Rock drills, pneumatic hammer, excavator, front end loader, derrick crane, compressor Trucks: Dump trucks, flatbed trucks
2B	Distribution chamber excavation (blasting, except at E. 54 th Street/Second Avenue Site, where hydraulic splitting would be used)	On-site: Derrick crane, excavator, rock drills, compressor, pneumatic hammer, front-end loader Trucks: Concrete trucks, dump trucks, flatbed trucks	Shaft excavation, line shaft with concrete. E. 59 th Street/Second Avenue and E. 61 st Street Sites: blasting; E. 54 th Street/ Second Avenue Site: hydraulic splitting at top, blasting below	On-site: Excavator, front end loader, derrick crane, compressor, pneumatic hammer Trucks: Dump trucks, flatbed trucks
2C	Slashing/lining the shaft by drill and blast (top portion by hydraulic splitting at E. 54 th Street/Second Avenue Site)	On-site: Derrick crane, rock drills, compressor, front-end loader Trucks: Concrete trucks, dump trucks, flatbed trucks	No Stage 2C for surface excavation	
3	Install riser piping and refill with concrete; distribution chamber construction (form/place reinforced concrete)	On-site: Derrick crane, front-end loader, compressor, pumper truck Trucks: Concrete trucks, dump trucks, flatbed trucks	Same as for raise bore	Same as for raise bore
<i>Contracting and Equipment Procurement Period: Site Secured and Inactive</i>				
EQUIPMENT INSTALLATION				
4A	Installation of distribution pipes and valves; completion of riser/distribution chambers (mechanical, electrical, plumbing); install piping	On-site: Excavator, crane, front-end loader Trucks: concrete trucks, flatbed trucks, dump trucks	Same as for raise bore	Same as for raise bore
4B	Construction of regulator and valve chambers (excavate, form, and pour chambers, install equipment)	On-site: Excavator, crane Trucks: concrete trucks, flatbed trucks, dump trucks	Same as for raise bore	Same as for raise bore
4C	Demobilize and grade site; water main connections at edge of Shaft Site; restore site	On-site: Loader, compactor, backhoe, cherry picker, paver Trucks: flatbed truck, dump trucks	Same as for raise bore	Same as for raise bore
5	Water main connections (excavate trench, relocate/protect utilities, lay bedding/pipe, backfill, pave)	On-site: Backhoe, cherry picker, paver Trucks: dump truck, flatbed trucks	Same as for raise bore	Same as for raise bore

Stage 2

Stage 2 would involve excavation of the shaft and distribution chamber, and can be further divided into Stages 2A, 2B, and 2C. This stage would be substantially different depending on whether raise bore excavation or surface excavation is used, as described below.

Stage 2A

Raise Bore

Stage 2A would consist of the excavation of the vertical shaft from the bottom upwards, with the excavated material removed from the bottom of the shaft through City Water Tunnel No. 3. This task would not begin until City Tunnel No. 3 has been extended to its terminus location beneath the Shaft Site. Using the raise bore technique, there would be little activity at the surface of the Shaft Site during Stage 2A.

The raise bore machine is essentially a large motor that drives a powerful drill at low speeds. The first step in the process would be to use the raise bore machine to drill a 12- to 18-inch diameter “pilot” hole at the center of the shaft from the top of the rock down to the Tunnel below. As the depth of the drilling increased, additional lengths of drill would be added to the machine. These would be stored on the Shaft Site within the construction area before they are added to the machine. While the pilot hole is being drilled, a slurry liquid would be pumped to remove the ground rock being created; this slurry would be removed by truck (an estimated total of seven trucks over the one-month period when the pilot hole is drilled).

Once the pilot hole is completed, the raise bore machine (with a 10-foot diameter head attached) would be used to drill the shaft from City Tunnel No. 3 up to the surface. The machine and workers would operate from the bottom of the shaft, and the drilled rock would fall to the bottom of the shaft for removal through City Tunnel No. 3 to existing Shaft 26B on the West Side of Manhattan. During site preparation, electric power would be brought to the site through a small-diameter hole drilled down to the water tunnel below. The power would be brought through the Tunnel and to the surface at the Shaft Site.

Surface Excavation

If City Tunnel No. 3 could not be used for removal of excavated material, Shaft 33B could not be constructed from below using the raise bore method. In that case, all excavation for the chambers and shaft at the alternative Shaft Site would have to be conducted from the surface (the “surface excavation method”). Stage 2A would consist of excavation of the distribution chamber, using controlled drilling and blasting to create the chamber from the surface level, rather than a raise bore machine. At the E. 54th Street/Second Avenue Shaft Site, excavation close to the surface would be conducted using alternative excavation techniques, such as hydraulic splitting, to limit vibration effects on buildings in close proximity. The protective measures to be employed during blasting are described below in the discussion of Stage 2B. Excavated soil and rock would be removed from the site by trucks for the entire chamber and shaft excavation using the surface excavation method.

During Stage 2A no pilot hole would be drilled for the shaft, and power would not be provided from City Tunnel No. 3 below; instead, the contractor would obtain power from Con Edison for the construction activities at the site.

Stage 2B

Raise Bore

Stage 2B would consist of excavation of the remainder of the distribution chamber. The initial excavation, conducted in Stage 1, involved removal of soil. Stage 2B would involve removal of rock within that excavation area, to bring the base of the chamber to its final elevation. At most sites, the rock would be removed by controlled drilling and blasting. However, at the E. 54th Street/Second Avenue Shaft Site, where blasting would not be conducted close to the surface, alternative techniques such as hydraulic splitting would be used instead (see Section 8.1 for more information on this technique). The rock displaced during blasting (or hydraulic splitting) would be removed through City Tunnel No. 3.

Controlled drilling and blasting involves drilling many small (i.e., 2-inch) holes in the rock using rock drills, and then placing small amounts of explosives in each hole. Blast mats are then placed on the rock, to control potential flying debris during blasting. Under carefully controlled and monitored conditions, explosives are then detonated sequentially, breaking the rock while spreading the release of energy from individual explosives, lessening the potential ground vibration and air blast effects above. Blasting procedures are developed on a site-specific basis depending on geological conditions as well as traffic and other environmental conditions at the time of blasting. Construction specifications would require adherence to all applicable rules and regulations, including the rules and regulations of the FDNY, and would require the use of modern blasting techniques including timed multiple charges, blast mats, etc.

When blasting would be conducted, one to two blasts would be expected to occur on a given day. The typical blasting sequence is as follows:

- Placement of explosives (1 to 2 hours)
- Placement of blasting mats (1 hour)
- Detonation of explosives (instantaneous)
- Removal of blast mats (1 hour)

After this sequence, the Contractor could either place a new round of explosives (if holes are already drilled) or clear the rock down the hole. Because the entire process takes three to four hours or more, it is highly unlikely that more than two blasts would occur on a given day. Based on experience with other construction projects that involve blasting, it is expected that blasting would typically occur during the first shift (7:00 to 3:00 pm). In general, blasting would not occur until 10:00 a.m. since it can take two to three hours to prepare for the blast. The second blast, if it occurred, would generally take place either in the early afternoon (i.e., around 3:30 p.m.) or towards the end of the evening peak period (i.e., around 6:30 p.m.). FDNY restricts blasting times to between 7:00 a.m. and 7:00 p.m. or sunup to sundown. Although not expected

to be needed, subject to prior approval and issuance of a variance by FDNY, extension of blasting operations may be granted on a case-by-case basis.

Blasting would be conducted in a manner that is protective of public health and safety, in coordination with FDNY. At the beginning of the blasting process and continuing potentially until the blasting is at a depth of 100 feet, these protective measures would include vehicular and pedestrian traffic being prohibited from traveling adjacent to the site.

Typically, a few minutes prior to blasting, warning whistles would alert the area that blasting was about to begin. The typical warning whistle communication protocol could result in the halting of vehicular and pedestrian traffic near the blast site as follows:

- 1 long whistle – vehicular and pedestrian traffic stopped
- 2 short whistles – blast will commence
- 3 long whistles – all clear: blast is completed and traffic flow can resume

This warning whistle communication protocol could take up to five minutes to implement. However, the typical warning whistle communication protocol can be modified to relatively short periods upon approval from the FDNY. Based on discussions and concurrence reached with the FDNY, NYCDEP would seek a whistle waiver from FDNY to permit a blasting sequence that is substantially shorter than usually employed for other blasting sites. The FDNY has indicated that they could issue a waiver to the protocol and reduce the whistle warning time to one minute. The waiver would permit a blasting sequence that is safe and functional, and would minimize the need for traffic and pedestrian stoppages during such events. This blasting sequence would be as follows:

- The contractor would notify flag persons or TEAs who are on standby at locations designated for traffic and pedestrian stoppages that everything is properly set up for the blast. Personnel from FDNY and the New York City Police Department (NYPD) would likely be on site during the initial blasts and may also participate in the traffic halting process, if warranted.
- At this time, the contractor would blow one long whistle, as noted above for standard blasting procedures, at which time flag persons would halt vehicular and pedestrian flow at the designated locations. Once traffic is stopped and the area near the site (generally approximately 100 to 150 feet away) is cleared, the flag persons/TEA would radio back to the site to confirm that stoppage is complete.
- The contractor would then blow two short whistles to signify that the blast is about to begin and set off the explosives with a trigger.
- Upon the instantaneous completion of the blast, the contractor would blow three short whistles and communicate to the flag persons via radio to indicate the end of the blasting sequence for vehicular and pedestrian traffic movements to proceed.

The duration of the above sequence (including the preliminary notification to the flag persons to get ready) is estimated to be approximately 2 to 4 minutes, with the temporary stoppage of traffic lasting about 1 minute. This duration would only be slightly longer than the typical signal

stoppage (usually 40 to 50 seconds) at nearby intersections, and while increasing delays, would not result in sustained back-ups. At times when the passage of emergency vehicles coincides with blasting events, the execution of the above sequence would be halted until the passage of the emergency vehicles is completed.

In addition, measures would be taken to protect surrounding structures from potential vibration damage during blasting. These are described in detail in the analysis of vibration for the preferred Shaft Site, Section 4.14 in Chapter 4. As described there, blasting is regulated by a NYCDEP Tunnel Construction permit and by the FDNY. To reduce vibration levels associated with blasting, construction specifications would require adherence to all applicable rules and regulations (including the rules and regulations of the FDNY). In addition, during construction, vibration levels would be monitored in nearby structures and/or at the site perimeter during all blasting activities by qualified personnel in the employ of an independent vibration consulting firm.

NYCDEP and its contractors would conduct extensive outreach to those in the vicinity of the Shaft Site that could be affected by blasting. This would include providing the nearby community with the expected start date for blasting operations, the general time pattern during the ensuing months, and the timing and significance of the warning whistles.

Surface Excavation

If the surface excavation technique is used, Stage 2B would consist of excavation for the shaft using controlled drilling and blasting, except at the E. 54th Street/Second Avenue Shaft Site where the shaft would be excavated using alternative techniques, such as hydraulic splitting, to limit the vibration at adjacent structures. The shaft and chamber would also be lined with concrete during Stage 2B.

Stage 2C

Using the raise bore technique, Stage 2C would include enlarging the diameter of the shaft from the 10-foot diameter (created by the raise bore machine) to the final diameter (approximately 22 to 27.5 feet wide) and lining the shaft with concrete. No Stage 2C would be needed for the surface excavation technique.

In Stage 2C, the shaft would be widened using controlled drill and blasting, using the same safety precautions as described above in Stage 2B. This process of widening the shaft is referred to as “slashing.” At the E. 54th Street/Second Avenue Shaft Site, the top portion of the shaft would be widened using an alternate technique, such as hydraulic splitting; blasting would begin once the excavation was deeper in the shaft. FDNY will require temporary stoppage of traffic and pedestrians adjacent to the site for blasting up to 100 feet below the surface. Upon concurrence from FDNY, at greater depths, it would no longer be necessary to stop traffic in the immediate area while blasting occurs. Workers would be lowered into and out of the shaft on a platform would be constructed at the base of the distribution chamber. The workers would be lowered to the appropriate depth on the platform and would drill holes in the shaft to be used for explosives placement. The cycle of drilling, blasting, and lowering of the platform would

continue until a 100-foot long section of the shaft has been finished. Following this cycle, the 100-foot section of the shaft would be lined with concrete. The concrete liner would vary in thickness depending on the depth, but would typically be one to two feet thick. Once the lining is completed, the next 100-foot section of the shaft would be enlarged and lined.

Stage 3

Stage 3 would include installation of the riser pipes (one or two 48-inch steel pipes) into the shaft and construction of the riser valve and distribution chamber. The riser pipes would be installed in 50-foot segments. Concrete would be poured into the shaft to fill the voids surrounding the riser pipes. The riser valve chamber, approximately 150 to 200 feet below ground surface, would also be constructed during Stage 3. Construction of this valve chamber would consist of leaving a 25-foot-high void surrounding the riser valves, rather than filling them with concrete.

Stage 3 would also include construction of the reinforced concrete distribution chamber walls, floor, and ceiling in the area previously excavated for the distribution chamber (during Stages 1 and 2).

At the preferred Shaft Site, Stage 3 would also include the construction of reinforced concrete extensions to the nearby Queensboro Bridge. As described in more detail in Section 4.1, this would involve creating wider underground piers that would extend from the surface down to bedrock, to protect the shaft from future Bridge expansion activities if this should ever be necessary.

Stage 4

Stage 4 can be further divided into Stages 4A, 4B, and 4C. Stage 4A would consist of installation of piping and valves in the distribution chamber, along with supporting utility equipment (lighting, plumbing, ventilation, etc.). Caps would be placed on the top of the riser pipes. The yard piping—the portions of the water main connection that begin within the Shaft Site boundaries—would be installed in an excavated trench. Excavation support would be used and the soil would be removed by dump truck. The various sections of the piping would be welded and/or bolted together.

Stage 4B would include construction of the regulator and valve chambers required for the water mains. At the preferred Shaft Site and most alternative sites, the regulator and valve chambers would be located beneath the street and sidewalk beyond the site boundaries. NYCDDC would construct the regulator and valve chambers; it is NYCDEP's intent to coordinate this work so it would occur during the final stage of shaft construction to avoid recurring disturbance to the site. During Stage 4B, a separate 10-foot-high construction barrier would be placed around this additional work area to serve as a buffer during construction. For these chambers, soil would be excavated and concrete floors would be placed, followed by installation of the 48-inch piping. Concrete walls and roofs would be poured into the chambers and the open excavations would be backfilled.

Stage 4C would include demobilization at the Shaft Site and restoration of the site, including regrading and repaving. Water main construction in the adjacent street may also occur during this stage.

2.5.2 Water Main Construction

NYCDDC would construct the two 48-inch water mains from Shaft 33B at any of the Shaft Sites in the streets using standard construction techniques and following NYCDOT traffic stipulations. NYCDDC is the City agency charged with design and construction of many of the City-sponsored construction projects occurring within City streets and sidewalks. This allows coordination of the various projects, so that disturbance to the street can be minimized. NYCDDC would coordinate and control the construction process. The specific construction methods to be used for the water mains therefore have not yet been determined. However, based on past NYCDDC practices, it is likely that water mains would be constructed using the “cut and cover” technique, which involves excavating small areas at a time and covering them once construction is complete. When appropriate, cut-and-cover construction can also involve use of temporary plates above excavated areas to allow access across a portion of the construction zone when work is not occurring there.

Using this technique, the water mains would likely be constructed in segments so that the entire construction route would not be disrupted simultaneously. Each segment would likely consist of a single block, not including its intersections, or a single intersection where a main must cross another street. For example, using the First Avenue route from the preferred Shaft Site, the first segment is likely to include the portion adjacent to the Shaft Site where venturi chambers would be constructed, and other segments would most likely consist of individual blocks of First Avenue or individual intersection crossings. To expedite the schedule, work could be conducted on several non-adjacent segments simultaneously.

Using cut-and-cover techniques, construction of a water main along a segment would typically include four steps, each lasting two to four weeks:

- **Step 1: Pavement cutting and excavation:** This step would involve cutting the existing roadway asphalt and concrete base and excavating a trench for the water mains. The sides of the excavation would be supported by steel sheeting, timber planks, or other supporting measures.
- **Step 2: Support and relocation of other utilities:** Existing utilities that cross the excavation area or that could be undermined by the open trench would be supported, protected, and/or relocated, as necessary.
- **Step 3: Placement of bedding and water main:** “Bedding” material (i.e., materials used to support the loading of the water mains in the excavated trench, such as gravel or sand) would be placed in the trench or a reinforced concrete cradle would be poured to support the water main. The water main would be placed into this bedding, aligned, and welded to the connecting joint.

- **Step 4: Backfill and repaving:** The trench would be backfilled with clean fill or sand, supporting materials would be removed, and the street would be repaved.

Construction work for the water main connections would occur during one eight-hour shift per day. This would typically occur during the daytime, but work could also potentially occur during an evening shift (from 3:00 p.m. until 11:00 p.m.) if NYCDOT Office of Construction Mitigation and Coordination (OCMC) deems evening construction work to be necessary to avoid severe traffic tie-ups. It is also possible NYCDOT may require weekend work or water main construction during the overnight shift (11:00 p.m. to 7:00 a.m.). Given the residential nature of the surrounding area, it is not anticipated that OCMC would request overnight work; however, this EIS addresses the potential effects of such work in relevant analyses.

Water main construction is conservatively estimated at up to 12 weeks for an avenue or street block segment and up to 10 weeks for an intersection segment. Several different options are available for the staging of the water main construction, requiring temporary closure of one to three traffic lanes at a time. For the reasonable worst-case route (First Avenue) from the preferred Shaft Site, the anticipated timeframe for the completion of the water main connections from the preferred Shaft Site would be 41 months. More information on construction of the water main connections is provided in Section 5.1, “Project Description,” in Chapter 5, “Water Main Connections.”

Although this EIS assumes the use of cut-and-cover construction for the water main connections, it is possible that other techniques for water main installation may be identified that involve less disruption to the street surface. For example, it may be possible to install water mains across major intersections by “pipe jacking.” Using this process, a pit is dug and the pipe is pushed through the existing soil beneath the street by hydraulic equipment. A second pit is required at the terminus point.

Another possible option for constructing lengths of water mains is “microtunneling,” which involves drilling a small tunnel below the street using a tunnel boring machine. The tunnel boring machine is launched from a pit dug at the start of the tunnel segment. This pit must remain in place for the duration of the construction, so that soils and rock excavated by the boring machine can be removed from the pit. A second, “receiving” pit must also be created for removal of the tunnel boring machine. When microtunneling would be used over several blocks or longer, intermediate pits must also be dug to allow the drilling heads on the machine to be replaced.

While these two options could potentially reduce the amount of disturbance on streets where water mains would be installed, they could also potentially increase the amount of disturbance where jacking, receiving, and interim pits would be created. For analysis purposes, this EIS considers the potential environmental effects of cut-and-cover construction for water main connections, since this is traditionally the method used by NYCDDC and because these effects generally represent the reasonable worst-case effects that can occur from water main construction. NYCDEP will work with NYCDDC to join expertise about possible construction techniques that would minimize street disturbance and the duration of construction.

2.5.3 Overall Construction Schedule

The total construction period for Shaft 33B, including the 8-month period in which the site is secured and inactive while equipment is procured, is an estimated 52 months at the preferred Shaft Site. As described earlier, construction of Shaft 33B is planned to occur in coordination with the construction schedule for City Tunnel No. 3, which is currently under construction. City Tunnel No. 3 is currently being excavated using a Tunnel Boring Machine, with material being removed from the existing construction area at Shaft 26B, near Tenth Avenue in West Midtown. Following excavation, the Tunnel will be lined with concrete, filled with water, and activated. The current goal is to complete construction of City Tunnel No. 3, Stage 2 Manhattan Leg by the end of 2008. Once the Tunnel is lined with concrete, it can no longer be used to transport excavated materials from construction of Shaft 33B. Under the current schedule, the Tunnel would have to be lined by the end of September 2007. Therefore, the last date for removal of excavated material from Shaft 33B into the Tunnel is the beginning of July 2007. This schedule would require that construction of Shaft 33B begin in the first quarter of 2006.

Table 2-2 shows the estimated construction schedule for Shaft 33B at the preferred Shaft Site, assuming an estimated March 1, 2006 construction start.

**Table 2-2
Anticipated Shaft Construction Schedule for Preferred Shaft Site
(Assuming Construction Start on March 1, 2006)**

Stage	Activity	Duration (Months)	Dates	
SHAFT AND DISTRIBUTION CHAMBER				
1	Site preparation	1	March 1 – March 31, 2006	
	Initial excavation, installation of excavation support, work slab	3	April 3 – June 30, 2006	
2	2A Drill pilot hole; raise bore the shaft	3	July 3 – September 29, 2006	
	2B Distribution chamber excavation	2	October 2 – November 30, 2006	
	2C Slashing/lining the shaft	6	December 1, 2006 – May 31, 2007	
3	Install riser piping	8	June 1, 2007 – January 31, 2008	
	Construct distribution chamber	4	February 1 – May 30, 2008	
	<i>Contracting and Equipment Procurement</i>	8	June 2, 2008 – January 30, 2009	
EQUIPMENT INSTALLATION				
4	4A	Installation of distribution pipes and valves	4	February 2 – May 29, 2006
		Completion of riser/ distribution chambers	6	June 1 – November 30, 2009
		Installation of piping at Shaft Site	2	December 1, 2009 – January 29, 2010
	4B	Construction of regulator and valve chambers	3	February 1 – April 30, 2010
	4C	Clean up	1	May 3 – May 31, 2010
		Restore site	1	June 1 – June 30, 2010

At the three alternative Shaft Sites, a variety of different circumstances could require a schedule with a longer duration than 52 months. As described in more detail in the respective “Project Description” Sections in Chapters 6, 7, and 8, this may mean that City Tunnel No. 3 is not available for removal of excavated materials from those Sites. Therefore, raise bore excavation may not be possible at the alternative Shaft Sites, and the EIS addresses the potential for surface excavation at these alternative Shaft Sites.

2.6 ACTIVATION

Once construction of the shaft and water mains has been completed, an activation procedure to disinfect the Tunnel and shaft and clear them of air and debris would be implemented before the shaft and connecting water mains can be used. Activation of Shaft 33B would likely occur at the same time as the activation for City Tunnel No. 3, Stage 2 Manhattan Leg. Since the NYCDEP has not initiated the design of the activation process for the City Tunnel No. 3, Stage 2 Manhattan Leg, detailed procedures to activate the Tunnel have not been developed at this time. However, the procedures used during activation of City Tunnel No. 3, Stage 1 can be used to represent activation procedures that would likely be utilized to activate City Tunnel No. 3, Stage 2.

The conceptual activation procedure for Shaft 33B would consist of three separate steps—shaft filling, shaft flushing, and shaft disinfection. Each step would last an estimated 3 to 5 days and would consist of the following:

- **Shaft Filling:** Initially, the shaft would be filled with water from City Tunnel No. 3. As the shaft fills with water from below, air in the shaft would be released through the above-ground air release hydrants. These activities would be contained within the shaft, and would last approximately three to five days. An estimated two workers would be on-site during this step.
- **Shaft Flushing:** In the next step, water from the existing surface distribution system would be allowed to flow into the shaft (so that the water is flowing “in reverse”) and into the Tunnel below. This step would also be contained within the shaft, and would last approximately three to five days. An estimated two workers would be on-site during this step.
- **Shaft Disinfection:** During this final step, the shaft would be filled with chlorinated water from the Tunnel below. Chlorinated water from the Tunnel would flow through the shaft and would be discharged from the air release hydrants to the local sewer system until the required chlorine level was achieved within the shaft. If chlorine levels are higher than appropriate for discharge to the local sewer system, the chlorinated water would be de-chlorinated before it is discharged. In this case, a small (10-cubic yard) treatment tank used for dechlorination would be located on site. The chlorinated water would be mixed with sodium bisulfite in the mixing tank, thereby reducing the chlorine levels to an amount suitable for discharge to the sewers. It is anticipated that no more than one truck each day would be needed to deliver the sodium bisulfite. Once the required chlorine level was achieved in Shaft 33B, the chlorinated

water would be held in the shaft for a minimum of 24 hours, and then it would flow back into the Tunnel and would be discharged off-site at the Tunnel discharge point. An estimated four workers would be on-site during the shaft disinfection step.

Following activation of the shaft, Shaft 33B would begin operation.

2.7 OPERATION AND MAINTENANCE

Shaft 33B is anticipated to be operational in 2012. The shaft would operate unmanned, 24 hours a day, seven days a week. Water flow from the shaft to the water distribution system would be automatically controlled by the regulators and valve chambers, which are manually set at a particular pressure setting. In addition to the underground shaft and distribution chamber, there would be some features of the shaft that would be above ground. These include two at-grade access hatchways to the shaft, a 10-foot-high by 14-inch-diameter air vent located on the Shaft Site or sidewalk, and up to two air release hydrants (3-foot-high by 6-inch-diameter). Neither air emissions nor above-ground noise would be generated by the shaft during normal operations.

Although regular operations of the shaft would occur unmanned, maintenance crews would routinely visit the site several times a week for inspection and maintenance activities. A range of zero to five visits could be expected weekly. However, on average, 1 to 3 visits a week would be expected (roughly 10 or 12 visits total in a month). Typical maintenance visits are spent within the shaft itself and last for approximately five hours, but could last the entire day depending on what activities were occurring. The average crew of NYCDEP employees visiting the site would be anywhere from 2 to 10 people, however, most often, crews on site would be in the two to four people range with one or two vehicles traveling to the site. NYCDEP personnel could travel to the site via vehicle or truck, resulting in a range of trips to the site of 1 to 10 vehicles and/or trucks in a given a day (crews work together in minimum numbers of two). Certain maintenance trucks would need to park directly over the shaft to facilitate access of mobile maintenance equipment directly to the shaft; other vehicles visiting the site, including city vehicles, are not permitted to violate parking regulations and thus would be expected to park legally on or in the vicinity of the site.

Although not anticipated to occur in 2012, in the future, over the course of the shaft's operational life, equipment replacement would be necessary from time to time. Normal equipment replacement activities would be accommodated through the access hatchways existing on site. When equipment replacement is necessary, larger crews would be on the Shaft 33B site for several weeks at a time. Construction equipment and additional trucks would be necessary to facilitate these activities. In addition, the roof of the shaft is designed to be removable in order to accommodate replacement of the larger components of the shaft when necessary. When larger components of the shaft require removal and replacement, the area around the roof would be excavated and the roof slab removed; additional equipment, including a crane, would be necessary during these times which could endure for several weeks or more.

While the design expectancy (total replacement cycle) of the shaft equipment is expected to be 50-75 years, equipment replacement needs are difficult to forecast, because they are performed

on an as needed basis. Events such as normal equipment replacement (accommodated through the access hatchways on site) could happen on the order of every few years, while the removal of the shaft roof for major equipment replacement would be expected over the course of longer periods (10-75 years). This estimate is based on other shaft site equipment replacement activities for shafts located along City Tunnels No. 1 and 2, which were built to less stringent design standards than City Tunnel No. 3.

While the level of activity at the site would vary over time, overall, regular activities on the site would be confined to the maintenance visits that would involve activity below ground within the shaft itself. These activities would not generate excessive noise or traffic are not anticipated to other wise significantly disturb the surrounding community.

The regulator chambers associated with the water mains would be visited a minimum of once per week. Venturi chambers would be accessed approximately once per month. Similar to maintenance for the shaft, maintenance crews could have 2 to 10 people, with smaller crews expected on average and a corresponding number of vehicles and/or trucks if each traveled separately to the site. Equipment maintenance and repair would require potentially several weeks of activity at given chamber and similar to the shaft would be expected to occur on an infrequent basis over the course of many years.

2.8 PERMITS AND APPROVALS

Construction and operation of Shaft 33B and its water mains may require a variety of permits, approvals, or reviews by New York State and New York City agencies. The permits and approvals associated with construction of Shaft 33B at the preferred Shaft Site are listed below; information on the permits and approvals required for Shaft 33B at the alternative Shaft Sites is provided in the Project Description Sections of Chapters 6, 7, and 8.

2.8.1 Permits and Approvals for Shaft 33B

- FDNY Blasting Permits: FDNY regulates the transport and use of explosives within the City to ensure their safe usage. All blasting at the Shaft Site would be conducted in coordination with FDNY.
- NYCDOT Construction Activity Permits, Sidewalk Construction Permits, and Street Opening Permits: NYCDOT permits would be required for construction-related activities on sidewalks and within streets. These permits typically provide detailed stipulations for traffic and pedestrian control during construction.
- NYCDEP Tunneling Permit: These permits are required for all tunnel construction in the City and set specific limits on blasting and noise levels, construction area layout, muck removal, and other aspects of tunnel construction.

- NYCDEP Sewer Discharge Permit: A permit would be required for discharge into the sewer during the dewatering and shaft activation process. This permit would specify the quality and quantity of water that can be discharged into a City sewer.
- Memorandum of Understanding between NYCDEP and NYCDOT: This document would outline the two agencies' agreement regarding NYCDEP's usage of NYCDOT property at the preferred Shaft Site.
- New York City Landmarks Preservation Commission (NYCLPC) Permit and Review: A permit would be required from NYCLPC for work on the piers of the Queensboro Bridge, which is a New York City Landmark. An advisory letter from NYCLPC would also be sought regarding construction activities adjacent to the Bridge. In addition, NYCLPC review regarding methodology and potential impacts of the project on historic resources was sought during the CEQR process.

2.8.2 Water Main Approvals

NYCDDC would implement construction of the water mains, and therefore is treated as an involved agency for environmental review under CEQR. In addition, the following other permits and approvals may be required:

- Metropolitan Transportation Authority (MTA) New York City Transit (NYCT) approval: Approval would be required from NYCT's Surface Transit Operations Division for temporary bus stop relocation during water main construction.
- NYCDOT Construction Activity Permits, Sidewalk Construction Permits, and Street Opening Permits: NYCDOT permits would be required for construction-related activities on sidewalks and within streets. These permits typically provide detailed stipulations for traffic and pedestrian control during construction.
- NYCLPC review: NYCLPC review will be required before in ground disturbance along any potential water main route in order to address potential archaeological sensitive along those routes. NYCLPC review will also be sought for construction of any water mains through designated New York City Landmark Historic Districts.
- New York City Department of Parks and Recreation (NYCDPR) Tree Work Permit: NYCDPR administers the street tree program in NYC. When street tree removal is required, NYCDPR must issue a permit and requires the project proponent to compensate the neighborhood for the loss of established greenery and provide additional street trees where possible in the general area of disturbance.

2.9 ENVIRONMENTAL REVIEW

This Final EIS has been prepared to assist decision-makers by providing a full disclosure of the environmental consequences of the proposed action. The EIS conforms with the requirements of New York City's City Environmental Quality Review (CEQR) as set forth in Executive Order 91

CHAPTER 2
PURPOSE AND NEED AND PROJECT OVERVIEW

of 1977 and its amendments creating the Rules of Procedure for CEQR, adopted by the City Planning Commission on June 26, 1991 and revised in October 2001, as well as the State Environmental Quality Review Act (SEQRA), Section 8-0113, Article 8 of the Environmental Conservation Law, as set forth in 6 NYCRR Part 617.

As lead agency, NYCDEP determined that the project may have potential significant adverse impacts on the environment, requiring the preparation of an EIS to provide full disclosure of all such impacts. This Final EIS examines the potential environmental impacts associated with construction and operation of Shaft 33B and its water main connections, describes mitigation measures for any significant adverse impacts, and examines alternatives to the proposed project.

On April 8, 2005, NYCDEP acting as lead agency publicly distributed a Draft Scope of Work for preparation of the Draft EIS for the proposed Shaft 33B project. A public hearing was conducted on May 9, 2005 to accept public comments on the Draft Scope of Work and comments were accepted via email and regular mail until July 6, 2005. A Final Scope of Work and Response to Comments were issued on July 25, 2005. The Draft EIS was prepared according to the Final Scope of Work.

Public review of the Draft EIS began on November 7, 2005 with the issuance of the Notice of Completion and the Draft EIS. As required under CEQR, the Draft EIS was available for public review for a minimum of 30 days following publication. The Draft EIS was circulated to interested and involved agencies and members of the public. A public notice advertising the availability of the Draft EIS and the date, time, and location of the public hearing on the Draft EIS was published in the City Record and in newspapers of general circulation in the affected area, including The New York Post, New York Daily News, and Our Town, a local weekly newspaper that is distributed in the Midtown area. The availability of the Draft EIS and information on the public hearing was also published in the New York State Department of Environmental Conservation's Environmental Notice Bulletin. The Draft EIS, on CD-ROM, was mailed directly to each member of the public who signed in at the public hearing on the Draft Scope of Work, provided comments on the Draft Scope of Work, or submitted comments on the project. In addition, the Draft EIS was posted on the NYCDEP web page and hard copies of the document were made available in local libraries and Community Board offices. NYCDEP also met with the local Community Boards, Community Boards 6 and 8, to present the Draft EIS to each Board on November 14, 2005. NYCDEP also hosted two informational forums to present the Draft EIS methodologies and analyses to the public. These informational forums, held on November 17 and 21, 2005, were intended to assist the public understanding the scope of the project and to assist the public in its review of the Draft EIS and included a substantial question and answer component. Copies of information presented at these sessions were posted on the NYCDEP website.

As required by CEQR, a formal public hearing was also held during the Draft EIS review period, to receive oral testimony from the public and from involved or interested public and private agencies. The public hearing was held on December 5, 2005 at the High School of Art and Design at 1075 Second Avenue in Manhattan. The public comment period remained open for 45 days, until December 22, 2005.

Following completion of the public review period, this Final EIS was prepared. The Final EIS includes responses to all substantive comments submitted during the comment period on the Draft EIS.

This Final EIS has been distributed in the same manner as the Draft EIS: the Final EIS, on CD-ROM, was mailed directly to each member of the public on the project’s mailing list, including those who provided comments on the Draft Scope of Work and Draft EIS as well as all attendees who signed in at the public hearing on either document and any others who asked to be added to the mailing list. In addition, the Final EIS was posted on the NYCDEP web page and hard copies of the document were made available in local libraries and Community Board offices. No less than 10 days following completion of the Final EIS, NYCDEP will make its final decision on the proposed location for Shaft 33B in the Statement of Findings prepared under CEQR.

2.10 ORGANIZATION OF THIS EIS

This EIS analyzes the potential environmental impacts associated with construction and operation of Shaft 33B and its water main connections. Potential impacts are evaluated for the preferred Shaft Site at First Avenue and E. 59th Street and for the three alternative Shaft Sites (the E. 59th Street/Second Avenue Shaft Site, E. 61st Street Shaft Site, and E. 54th Street/Second Avenue Shaft Site). Following Chapter 1 (Executive Summary) and Chapter 2 (Purpose and Need and Project Overview), this EIS is organized as follows:

- **Chapter 3, “Impact Methodologies:”** This Chapter discusses the methodology used to evaluate potential impacts associated with the proposed action in the subsequent chapters of the EIS. Methodologies are presented for each CEQR technical area evaluated for each site and the water mains in the remaining Chapters of the EIS.
- **Chapter 4, “Preferred Shaft Site:”** This Chapter evaluates the potential environmental impacts associated with construction and operation of Shaft 33B at the preferred Shaft Site, at E. 59th Street and First Avenue, for the full range of environmental impacts. Section 4.1 provides a project description for Shaft 33B at the preferred Shaft Site, and Sections 4.2 through 4.17 describe environmental impacts by technical area.
- **Chapter 5, “Water Main Connections:”** Chapter 5 evaluates the potential environmental impacts associated with construction and operation of water main connections from Shaft 33B at the preferred Shaft Site to the Third Avenue trunk main. A reasonable worst-case route and two additional representative routes are evaluated in this EIS to represent the potential impacts that could occur for the water main route selected in the future. Section 5.1 provides a project description for the water main connections, and Sections 5.2 through 5.17 describe environmental impacts by technical area.
- **Chapters 6 through 8, Alternative Shaft Sites:** CEQR requires that alternatives to the proposed action be identified and evaluated as part of the EIS process. The alternatives analysis should present reasonable options for reducing or eliminating project impacts, while substantively meeting project goals and objectives; demonstrating a reasonable range of

options to the proposed action; and comparing potential impacts under alternative approaches for meeting project objectives. Three alternative Shaft Sites are evaluated in this EIS in Chapters 6 through 8—Chapter 6, “E. 59th Street/Second Avenue Shaft Site;” Chapter 7, “E. 61st Street Shaft Site,” and Chapter 8, “E. 54th Street/Second Avenue Shaft Site.” In each of these chapters, the first Section (i.e., Section 6.1, 7.1, or 8.1) provides a project description for the alternative and the subsequent sections describe environmental impacts by technical area. The potential impacts associated with the construction and operation of the water main connections to each of these alternative Shaft Sites are described in those chapter as well.

- **Chapter 9, “Water Main Only Alternative:”** This Chapter evaluates the potential environmental impacts that would result if Shaft 33B cannot be constructed, and instead an approximately 40-block water main connection is created between the closest shafts to the north and south of the area where Shaft 33B is proposed.
- **Chapter 10, “No Action Alternative:”** CEQR requires the evaluation of a No Action Alternative, in which the proposed action does not take place and no discretionary actions associated with the project would occur. As noted above, if Shaft 33B is not constructed, the Water Main Only Alternative would likely be implemented instead. Nonetheless, Chapter 10 considers a No Action Alternative in which Shaft 33B is not constructed and no new water main construction occurs, to identify the specific advantages and disadvantages of not proceeding with the project.
- **Chapter 11, “Comparison of Alternatives:”** This Chapter provides a summary comparison of the potential benefits and adverse impacts from construction and operation of Shaft 33B at the preferred Shaft Site and each of the alternative Shaft Sites.
- **Chapter 12, “Growth-Inducing Impacts:”** This Chapter discusses the potential for the project to induce development activity that otherwise would not occur.
- **Chapter 13, “Irreversible and Irrecoverable Commitment of Resources:”** Chapter 13 provides a brief discussion of the resources that would be committed to the project.
- **Chapter 14, “Environmental Screening Analyses for All Alternatives:”** This Chapter summarizes the screening analyses conducted for environmental areas that did not require detailed evaluations in the previous Chapters.
- **Chapter 15, “Comments and Responses:”** This Chapter summarizes and responds to all substantive comments made during public review of the Draft EIS, from the date of publication of the document (November 7, 2005) through the close of the 45-day comment period (December 22, 2005).

Throughout the document, the EIS presents analyses that represent “reasonable worst-case” anticipated conditions. For example, final design is not complete for the shaft and its chambers and the specific details of construction and construction phasing have not yet been finalized, so the analyses in this EIS make reasonable worst-case assumptions based on prior experiences with shaft construction projects. As explained in Chapter 3, “Impact Methodologies,” each technical analysis uses conservative assumptions—for example, regarding the analysis year and

CHAPTER 2
PURPOSE AND NEED AND PROJECT OVERVIEW

construction techniques—that result in reasonable worst-case conclusions for that technical area. In addition, the analysis of water main connections considers the potential impacts of a reasonable worst-case water main connection route as well as two additional representative routes, so that the full range of potential environmental impacts for water main construction can be understood.

