

FIRE DEPARTMENT • CITY OF NEW YORK



INSTRUCTION MANUAL FOR THE REFRIGERATION SYSTEM OPERATING ENGINEERS Q-01/Q-99 PRACTICAL EXAMINATION

This book is provided to the public for free by the FDNY.

The printout copy provided in the FDNY Headquarters is printed in black and white. However, page 10-14 may be viewed best in color. Please visit the following website to view the original document.

<https://www1.nyc.gov/assets/fdny/downloads/pdf/business/cof-q01-rsoe-practical-exam-instruction.pdf>

The tutorial video could be viewed at:

<https://youtu.be/BQJw5ME56oI>

Introduction of the new RSOE practical exam

The new exam system is a major update to the certification process for operating engineers. This new certification exam is very different from the old one.

The exam is a 3D representation of an actual refrigeration system. It does not include actual images of actual components.

Exam Format

There are two sessions in the RSOE practical exam: (1) walk-through and practice exam (45 minutes) and (2) Actual exam with both Centrifugal and Reciprocating systems (240 minutes).

(1) Walk-through and practice exam (45 minutes)



In this session, you can explore both Centrifugal and Reciprocating systems including the layout and all components in the actual exam. You will take the practice questions in both systems to practice how to

- select a question,
- navigate the system to find the answers,
- submit answers,
- complete questions, and
- complete the exam.

Practicing all practice questions will also prepare you to be familiar with the use of navigation bar, tool box and reference materials.

The practice exam provides feedback so that you will know if you submitted the correct answers.

(2) Actual exam with both Centrifugal and Reciprocating systems (240 minutes)

After you completed the walk-through and practice session, you will start your actual exam.



You can choose either one system to start your actual exam. Once you start your actual exam, you have 240 minutes to complete all questions in Centrifugal and Reciprocating systems. You must complete one system first and then the other one. You cannot go back to the system that you have completed.

The label on top of the navigation bar tells you that which system you are currently working on.

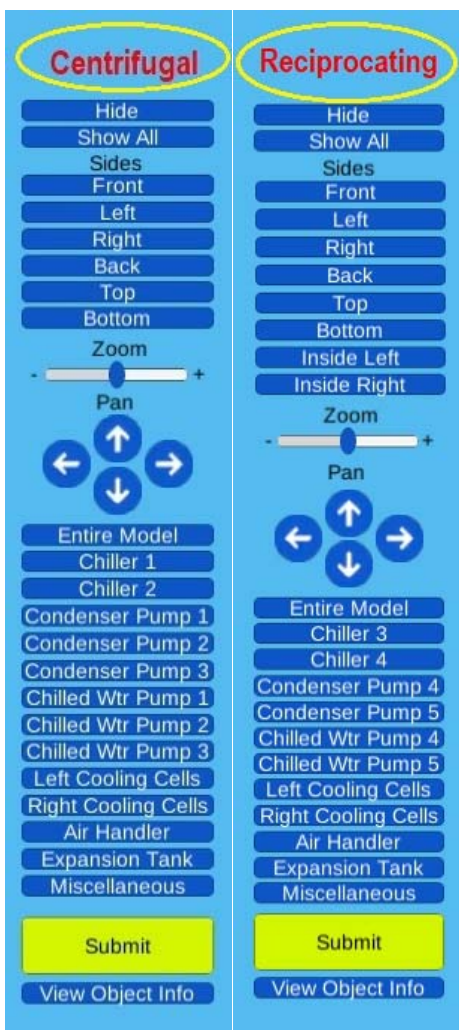

Question Categories

Questions on the exam in each system are divided into six categories. Those categories are Operations, Validation of Repairs or Maintenance, Refrigerant Handling, Troubleshooting, Multi-step Questions, and Scenario Questions.

Definition of each category:

1. Operations, which includes, but is not limited to, questions around the following topics at a comprehension-level of learning:
 - a. Component Identification;
 - b. Component Function;
 - c. Reading Gauges;
 - d. Calculations of Temperature/Pressure Differences;
 - e. Use of Pressure/Temperature Charts and Conversions

You need to know the locations and functions of each component.

2. Validation of Repairs/Maintenance, which includes, but is not limited to, questions around the following topics at a comprehension-level of learning:
 - a. Normal maintenance and repair problems;
 - b. Validation of repairs; c. Start-up procedures
3. Refrigerant Handling, which includes, but is not limited to, questions around the following topics at a comprehension-level of learning:
 - a. Recovery;
 - b. Charging.
4. Troubleshooting/Diagnosis of Issues, which includes, but is not limited to, questions around the topics of troubleshooting and diagnosing problems with system operations.

You need to interpret the readings and know which reference document is required for answering the questions.

5. Multi-step Questions
 - a. These questions include multiple sub-questions, but do not rise to the level of complexity of a scenario.
 - b. They are a combination of comprehension-level and application-level learning and represent areas of content covered in all the categories above.

Only one multi-step question in each system. A multi-step question may have a maximum of 6 follow-up questions.

6. Scenarios
 - a. These questions are at an application-level of learning and will, by their cumulative nature, include portions of the question/scenario that connect to the other categories
 - b. For example, the end-to-end recovery procedure for the reciprocating unit would go in this category, but a single question related to comprehending that process would be assigned to troubleshooting category.

Only one scenario question in each system. A scenario question may have a maximum of 16 follow-up questions.

Lessons Learned from the Pilot Examinees

The important lessons learned from the examinees who participated the pilot exam:

- You must watch the tutorial video several times.
- You must be familiar with the instruction manual.
- You should use the walk-through session to practice how to operate the exam and be familiar with the layout of the Centrifugal and Reciprocating systems.
- **It is a knowledge test not a memory test.**
- You must have a knowledge of the general layout of the systems, where each of the components are located and what their functions are.
- You must know how to identify inlet piping and outlet piping for chilled water vs condenser water or other systems.
- You must know the basic layout of the chiller systems and where components are located and their functions.
- The questions may not directly instruct you to use reference document. You must know when to use the reference documents to answer the questions. Examples of the reference documents may be used in the new practical exam: Safety Data Sheet (SDS), Pressure Temperature (PT) chart, Chiller Specification Sheet; Equipment schedules, and Reaction/Separation/Recycle (RSR) Operating Procedure Diagram.
 - *Special note for the RSR operation procedure diagram document:*

An RSR System is a self-contained package consisting of, among other things, a refrigerant compressor, storage receiver, water-cooled condenser and necessary valves and hoses, used to charge and remove refrigerant from a centrifugal chiller.

RSR operating procedure diagram includes the RSR system flow diagram and the operating settings. It is normally posted on every RSR unit in the field. If you don't have any field experience, you should be taught in the school regarding how this document looks like and how to understand and use this document.

In your exam, this document will be provided as one reference document that help to facilitate the proper operation of the RSR system. The RSR Flow Diagram provides a flow schematic that details the arrangement of the piping, valves and other components on the RSR System. The Diagram also details what components of the centrifugal chiller the RSR System refrigerant transfer hoses must attach. The Operating Centrifugal table provides various operating conditions required to accomplish refrigerant transfer. For example, the table provides details, depending on whether liquid or vapor refrigerant is being transferred, of the required position for chiller refrigerant service valves and RSR System valves, including RSR System manifold valves; whether the RSR System compressor must be running; whether water flow through the RSR System water-cooled condenser is required; and whether water flow through the chiller's evaporator is required.

Exam Preparation

To prepare this new exam, you have to:

1. watch the tutorial video several times.
2. know the basic layout of the chiller systems and where components are located and their functions.
3. be familiar with important system components and the color codes in the exam system
4. know how to obtain information from the control panel and gauges

1. Tutorial Video

This tutorial video is very critical for you to be familiar with the RSOE practical exam.

The video could be viewed via the following link:

<https://youtu.be/BQJw5ME56oI>

Or visit the following website to find the video link:

<https://www1.nyc.gov/site/fdny/business/all-certifications/certificates-of-qualification.page>

Since this new exam system is very different from the previous practice exam, you must watch the video carefully. Our pilot study has shown that people who did not watch this video carefully hardly know how to navigate the system, how to answer the question and cannot find the parts they need during the real exam. Please watch the video several times before your exam.

2. System Layout

This new exam puts a strong emphasis on knowing an entire chiller system, especially where individual components are located on a real chiller system. In order to answer the new exam questions, you need to navigate the entire chiller systems to find the components of the questions request. You must know where each component is located at a real chiller system in order to pass this exam.

The following pictures are NOT the exact same model of the exam system. However, being familiar with the components and their locations in these layouts will help you find the components in the exam to answer questions.

1) Centrifugal System

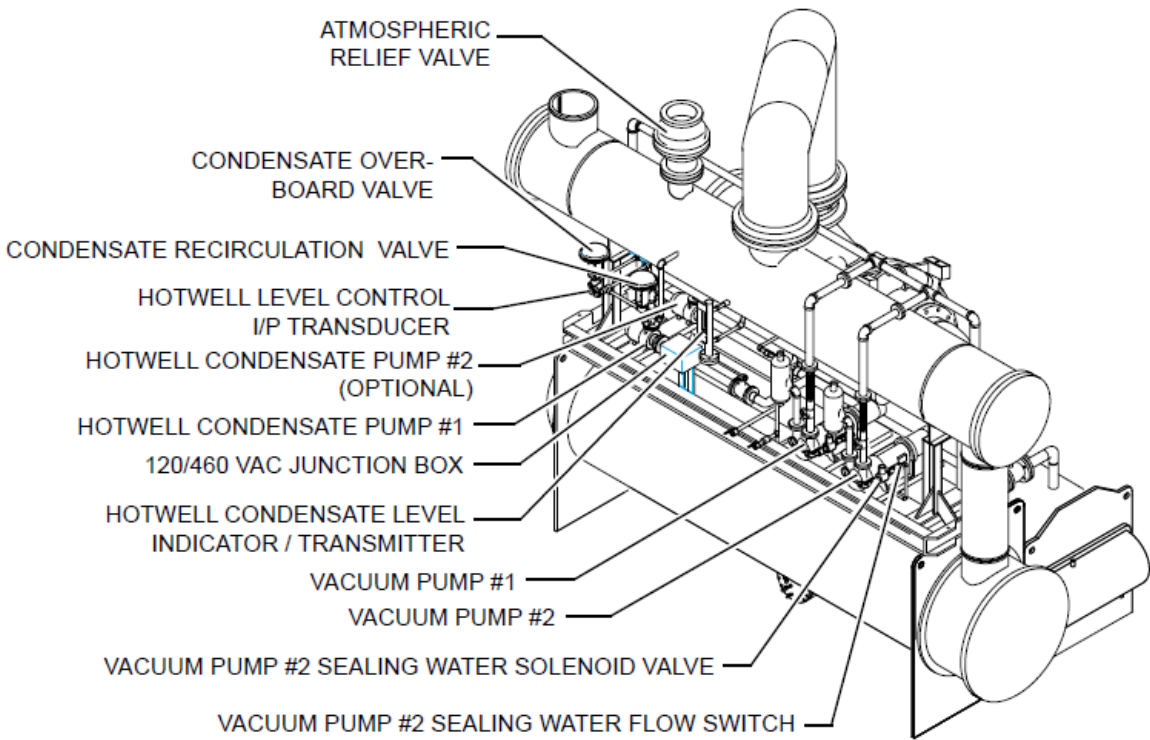
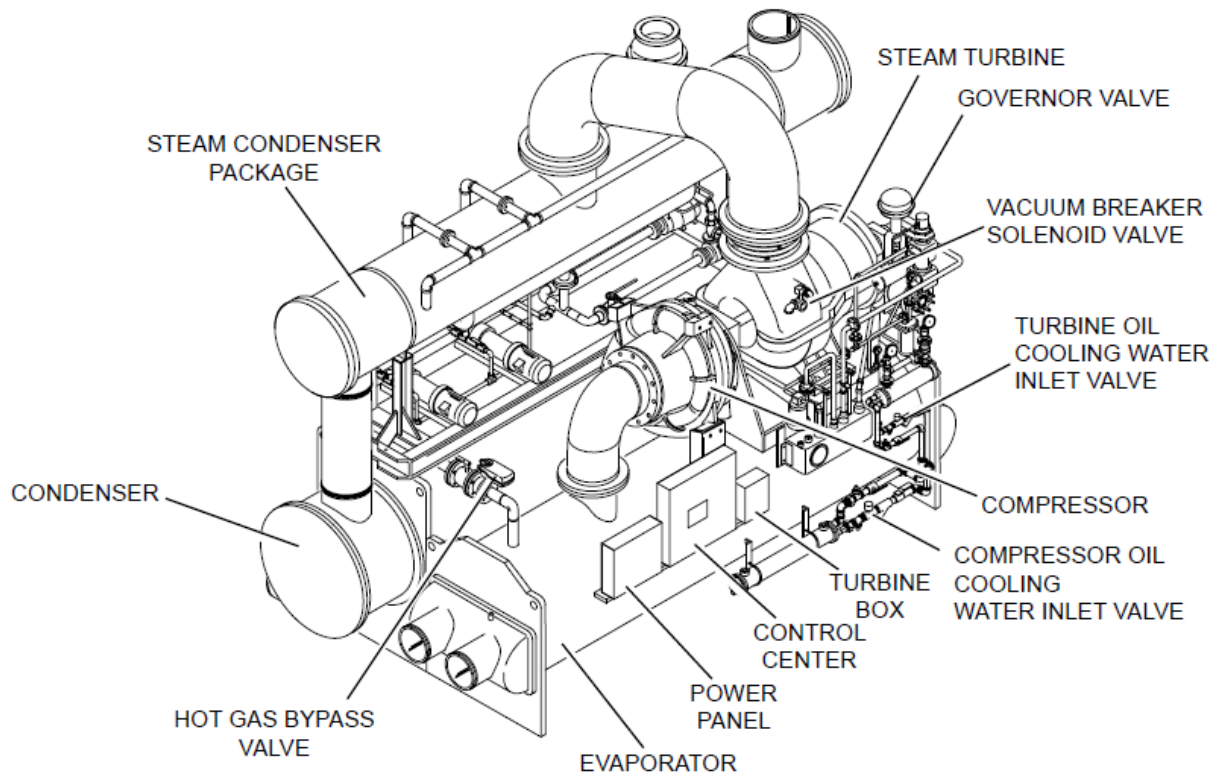

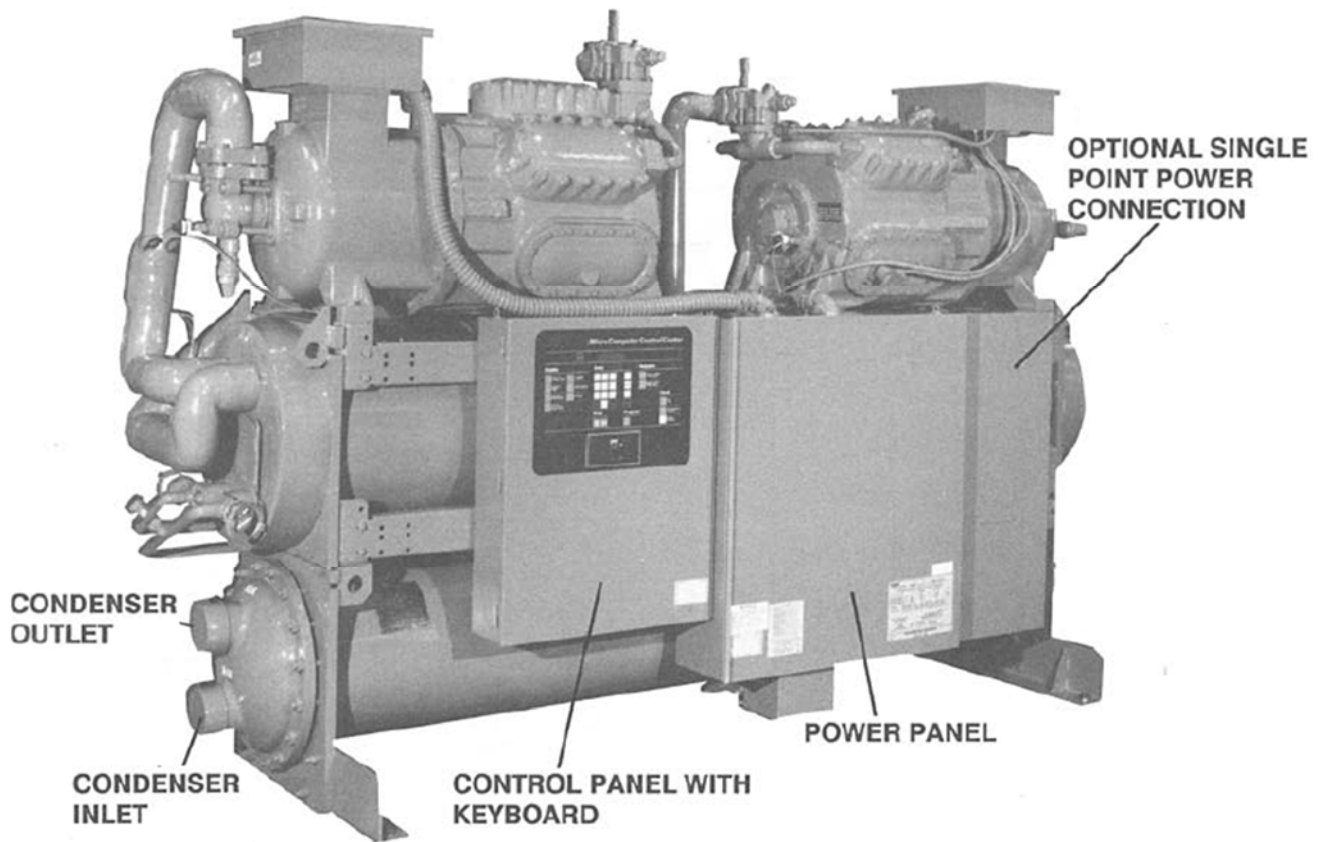
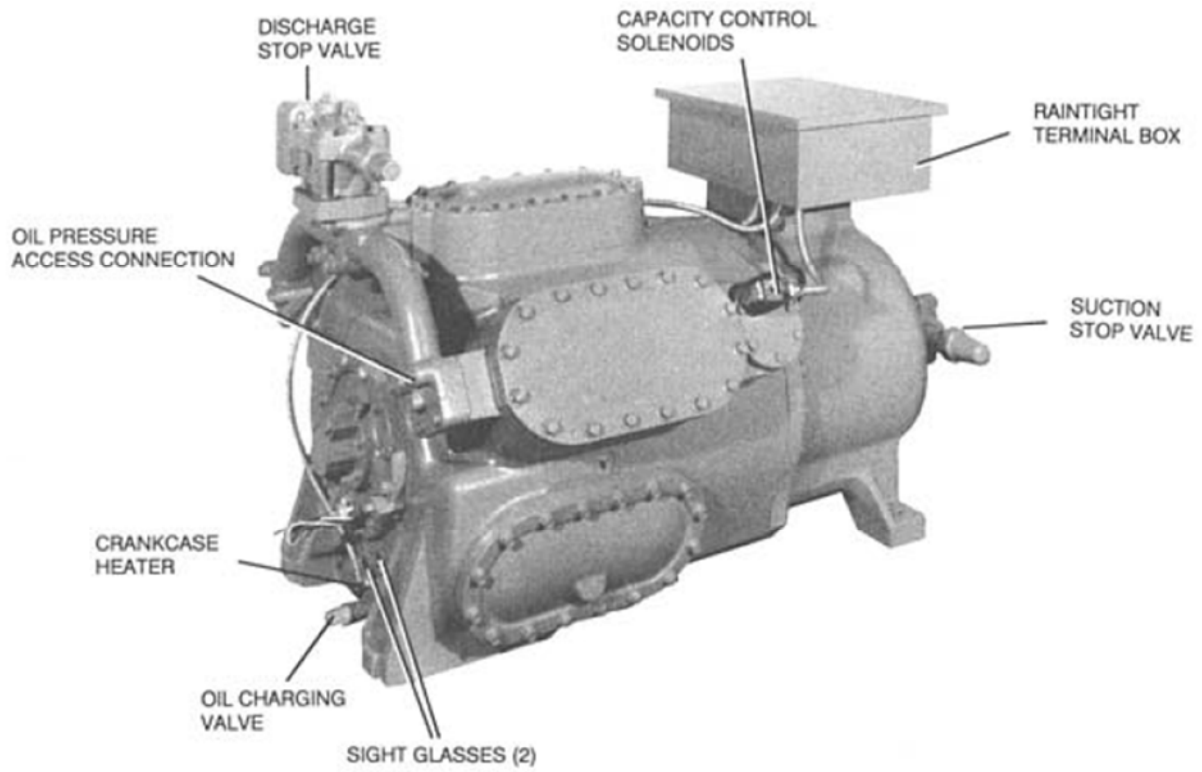

2) Reciprocating System

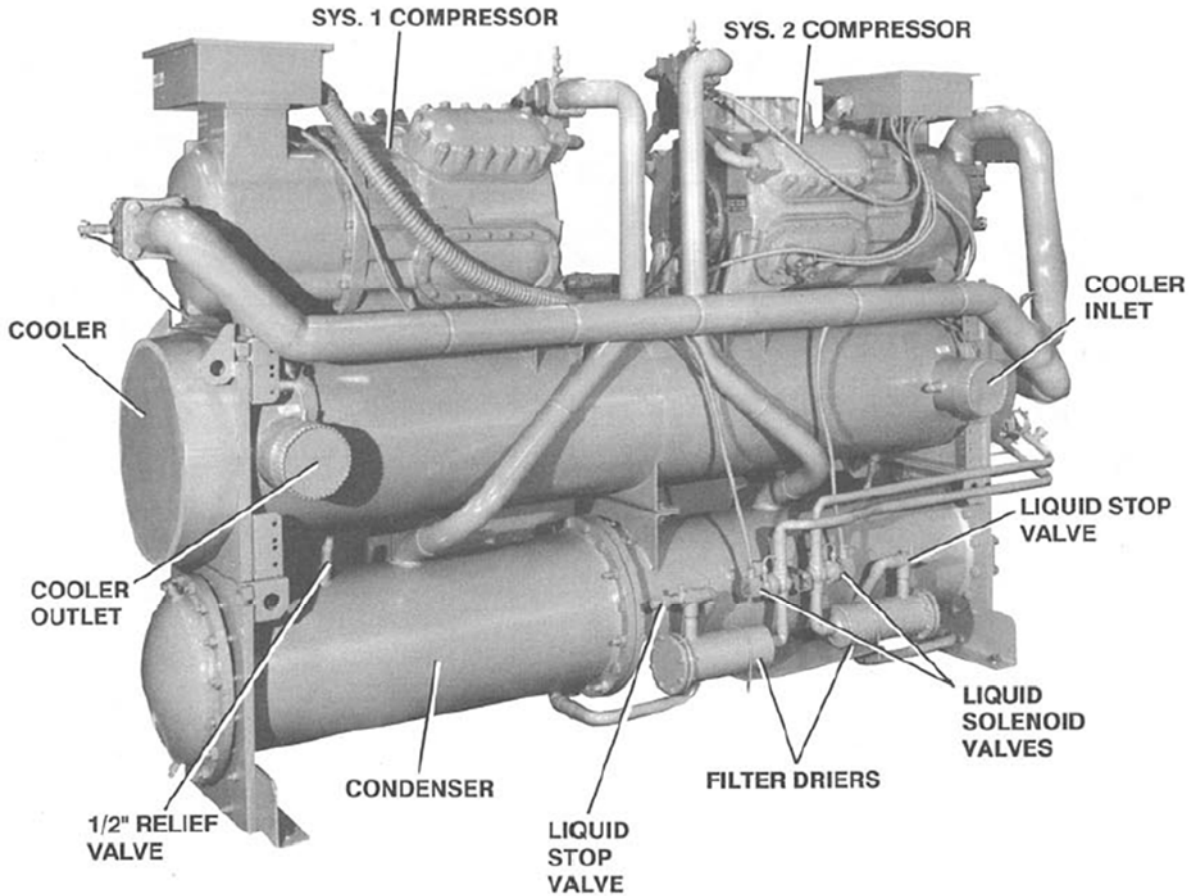





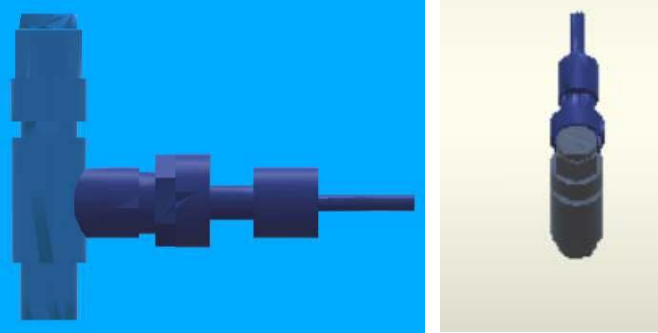
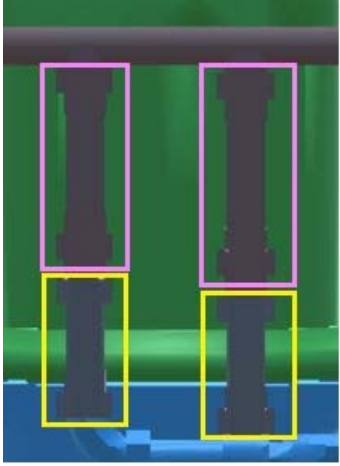

3. Component Legend and Color Codes

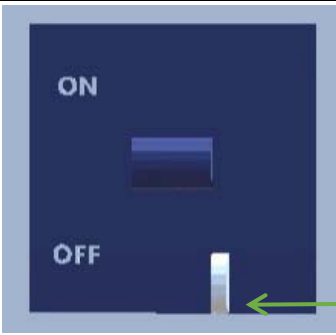
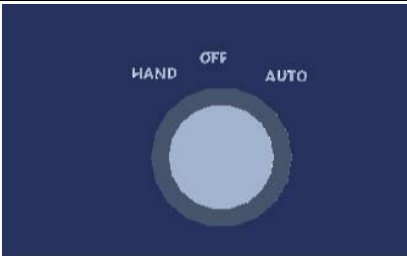

Since the new exam does not show real pictures of real objects, the following legend is your only resource for discerning between types of objects on the 3D model. Although the component legend and color codes will be provided in your exam, it is still critical that you memorize the information in this section. Being familiar with all the components listed below will help you to identify these components easier for answering the questions.

	3D model	Name of the Component(s)
1		Flow Switch
2		Temperature Sensor
3		Pressure Transducer (Dark Blue) On a Service Valve (Light Blue)
4		External Vent Piping (upper part, in pink rectangles) and Pressure Relief Valve (bottom part, in yellow rectangles)

5	 A black thermometer with a curved pipe at the bottom, set against a blue background.	Thermometer
6	 A black pressure gauge with a quarter turn valve below it, set against a blue background.	Pressure Gauge with Quarter Turn Valve below the Gauge
7	 A quarter turn valve on a pipe, set against a blue background.	Quarter Turn Valve
8	 A disconnect switch with 'ON' and 'OFF' labels. A LOTO attachment hoop is located below the switch. A green arrow points from a label 'LOTO attachment Hoop' to the hoop.	Disconnect Switch and LOTO attachment Hoop below it
9	 A selector switch with 'HAND', 'OFF', and 'AUTO' labels.	HOA Selector Switch

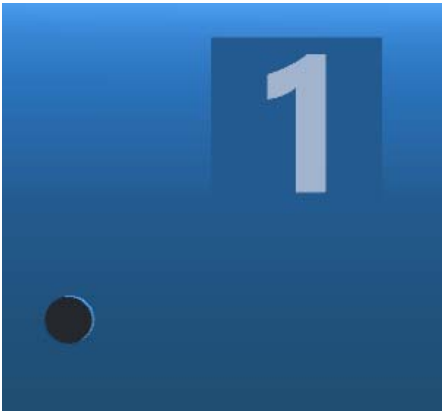
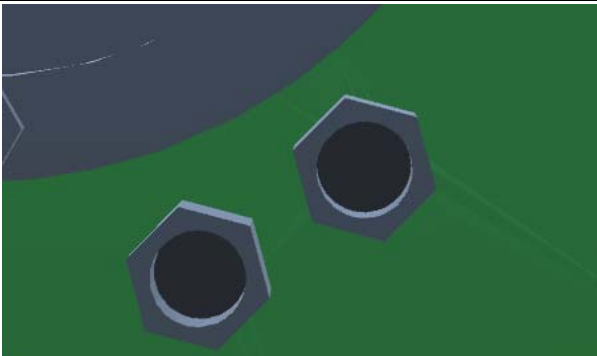
10		Bulb Temperature Sensor
11		Solenoid Valve
12		Automatic Valve
13		Service Valve
14		King Valve

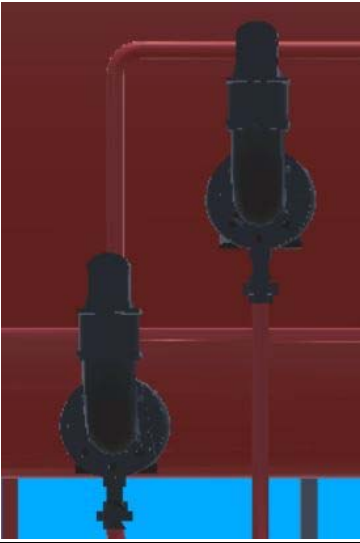
<p>15</p>		<p>Strainer</p>
<p>16</p>		<p>Glass Tube Site Glass</p>
<p>17</p>		<p>Round Window Site Glass</p>
<p>18</p>		<p>High and Low Nut-Shaped Window Site Glass</p>

<p>19</p>		<p>Low and High Level Floats</p>
		<p>Steam Trap on Drip Leg With Unions on Both Sides</p>

Color Code

Color	Component Categories
Dark Blue	Electronic valves and components
Light Blue	Evaporator and cold water components and piping
Brown	Contaminant filtration, venting and drain components
Tan	Condenser components and piping
Red	Surface condenser components and piping
Black	Non-electronic valves
Gray	Gauges and oil components and piping
Orange	Turbine components and piping
Green	Compressor components and piping

Information shown on the Control Panel and Gauges

Some questions may ask you to read or interpret the status/information shown by the control panel or gauges. There will be NO PHOTOS POPPED OUT next to the control panel or gauge for you to read. Instead, the information will be shown on different place. The examples are shown below:

(1) Control Panel

Based on the request of a question, you decide to click and submit the steam button on the control panel to find a pressure (the highlighted green button in the picture below).

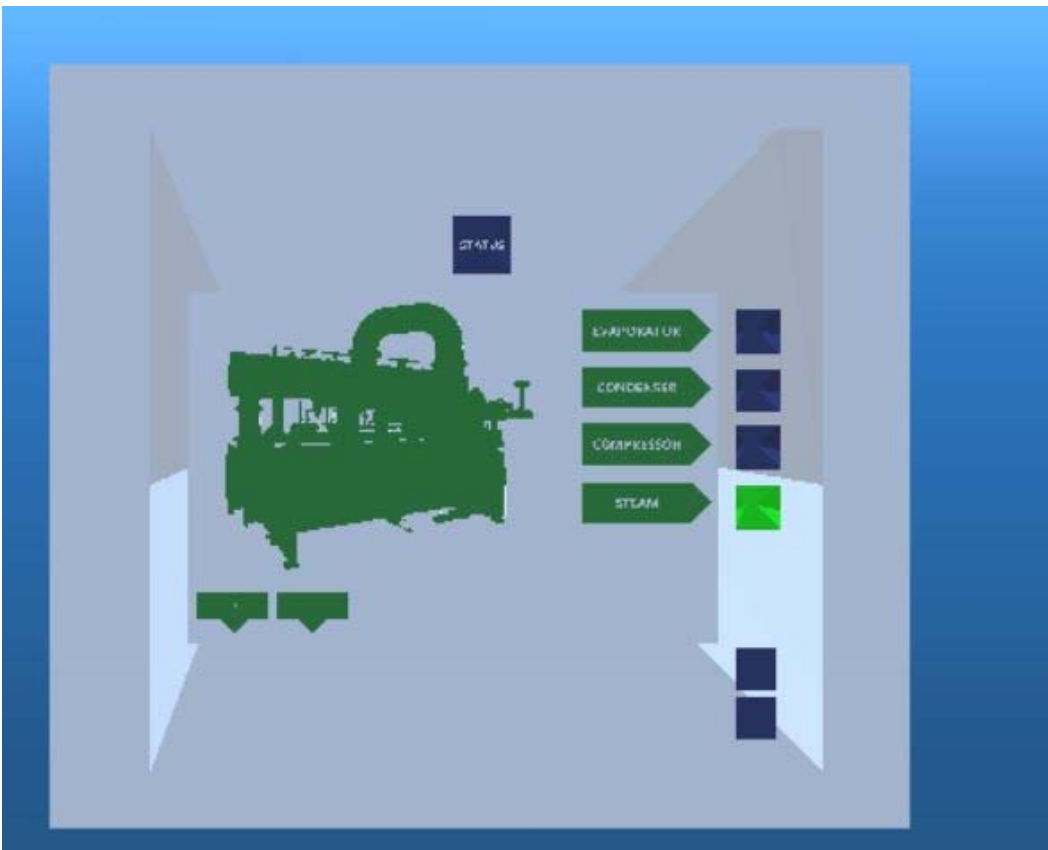

If you click the right button, the information will be shown under the minutes (see the circled information in the picture below)



You should answer the question based on the information.

THE STATUS INFORMATION WILL ONLY BE SHOWN WHEN IT IS NECESSARY.

If you randomly click and submit some buttons which are not related to the question, you may not see any information displayed on this status location.

You must click the right button to obtain the correct status information.

(2) Gauge reading

Based on the request of a question, you decide to click and submit one gauge of the condenser pump 1 to find the pressure (the highlighted green gauge in the picture below). The reading of the gauge will be shown under the minutes (see the circled information in the picture below)



The screenshot shows a software interface for a 'Chiller Exam'. On the left is a 3D model of industrial machinery with a green gauge highlighted. On the right is a status bar with a blue header containing the text 'Click Here to Move' and '20 Minute(s) Remaining'. Below this, the text 'Pump suction pressure: 8 psig' is displayed and circled in red. At the bottom right, a question box contains the text: '19.0) Select condenser pump 1 from the navigation bar. Identify the gauge that'.

You should answer the question based on the information.

THE STATUS INFORMATION WILL ONLY BE SHOWN WHEN IT IS NECESSARY. If you randomly click and submit some gauges which are not related to the question, you may not see any information displayed on this status location.

You must click the right gauge to obtain the correct status information.