

September 17, 2024  
Public Meeting

The current proposal is:

Preservation Department – Item 1, LPC-24-09829

**8 West 86th Street – Upper West Side/Central Park West  
Historic District  
Borough of Manhattan**

To testify virtually, please join Zoom

**Webinar ID:** 860 1689 5962

**Passcode:** 322206

By Phone: 646-558-8656 (NY)

877-853-5257 (Toll free) US

888-475-4499 (Toll free)

**Note:** If you want to testify virtually on an item, join the Zoom webinar at the agenda's "Be Here by" time (about an hour in advance). When the Chair indicates it's time to testify, "raise your hand" via the Zoom app if you want to speak (\*9 on the phone). Those who signed up in advance will be called first.



NEW YORK CITY  
LANDMARKS PRESERVATION  
COMMISSION SUBMISSION

LPC-24-09829

September 10, 2024



**Bard**  
Graduate  
Center

**8 WEST 86<sup>TH</sup> STREET** | PROPOSED STUDY COLLECTION BUILDING

**SUSAN T RODRIGUEZ**  
ARCHITECTURE • DESIGN



UPPER WEST SIDE /  
CENTRAL PARK WEST HISTORIC DISTRICT  
DESIGNATED APRIL 24, 1990  
LANDMARKS PRESERVATION COMMISSION

LANDMARK DISTRICT LP-1647

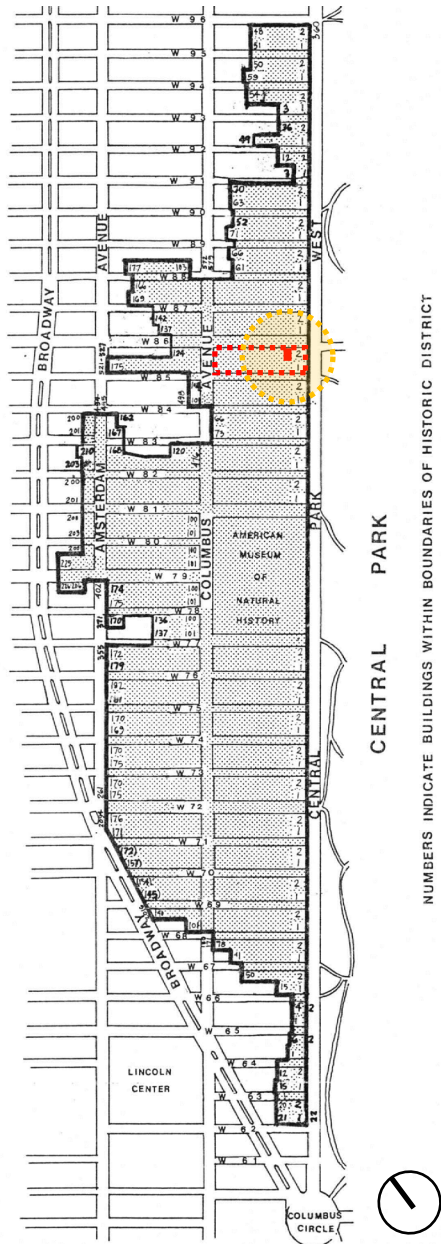

CENTRAL PARK  
NUMBERS INDICATE BUILDINGS WITHIN BOUNDARIES OF HISTORIC DISTRICT



EXISTING





**Bard  
Graduate  
Center**

Bard Graduate Center is devoted to the study of decorative arts, design history, and material culture through research, advanced degrees, exhibitions, publications, and events.

**FOUNDED in 1993.** Accredited through Bard College and a member of the Association of Research Institutes in Art History

- **MA AND PHD RESEARCH PROGRAMS** in Decorative Arts, Design History, and Material Culture
- **EXHIBITIONS** in the gallery and online emerge from classroom teaching and faculty research
- **PUBLIC PROGRAMS** including gallery talks and tours, lectures and seminars, symposia and performances





# SUPPORTING AN “OBJECT-BASED APPROACH TO PEDAGOGY”



Proposed Home for the BGC Study Collection



Study Collection “Object Highlights”









# A BUILDING FOR THE BGC STUDY COLLECTION





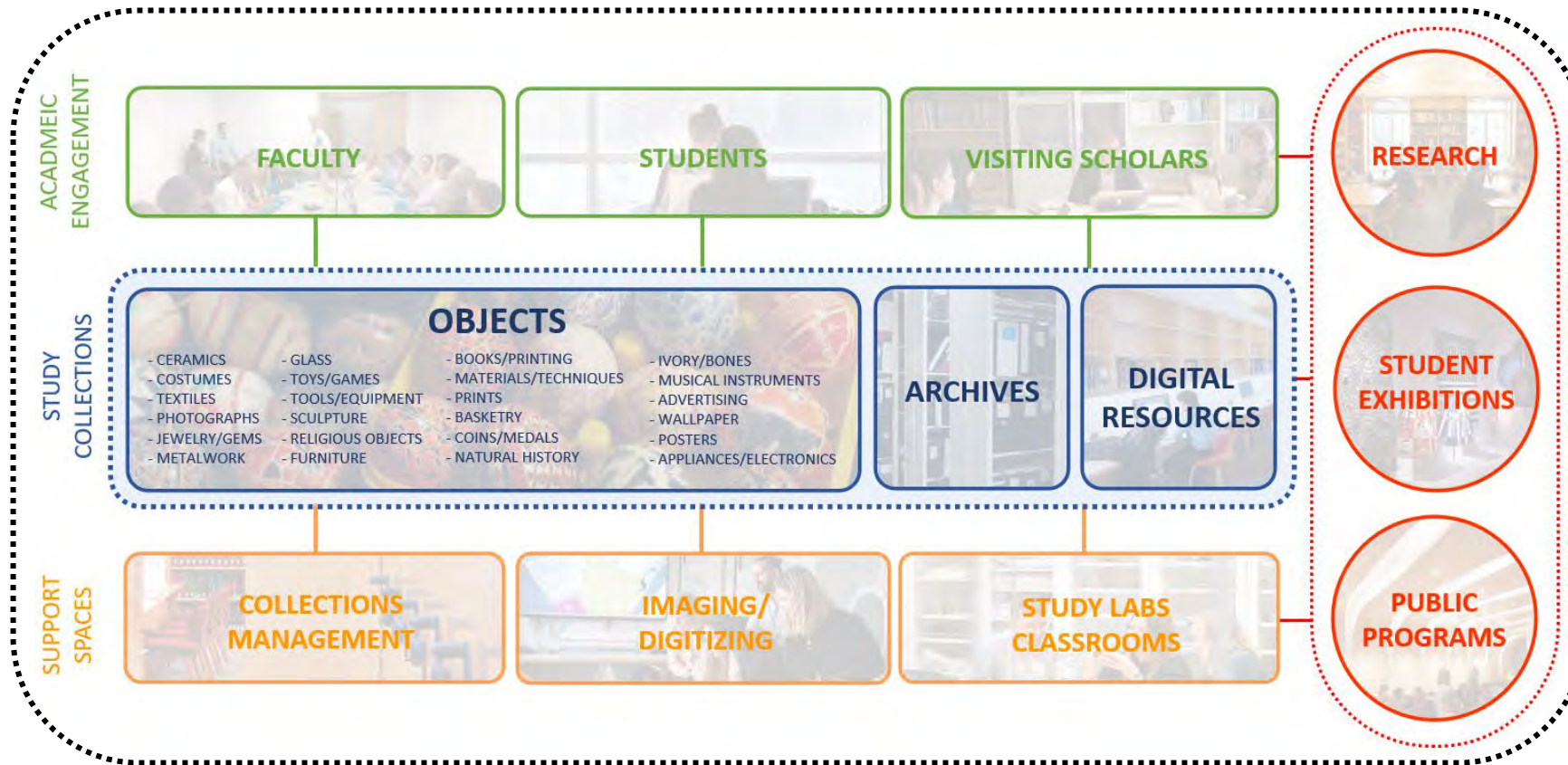



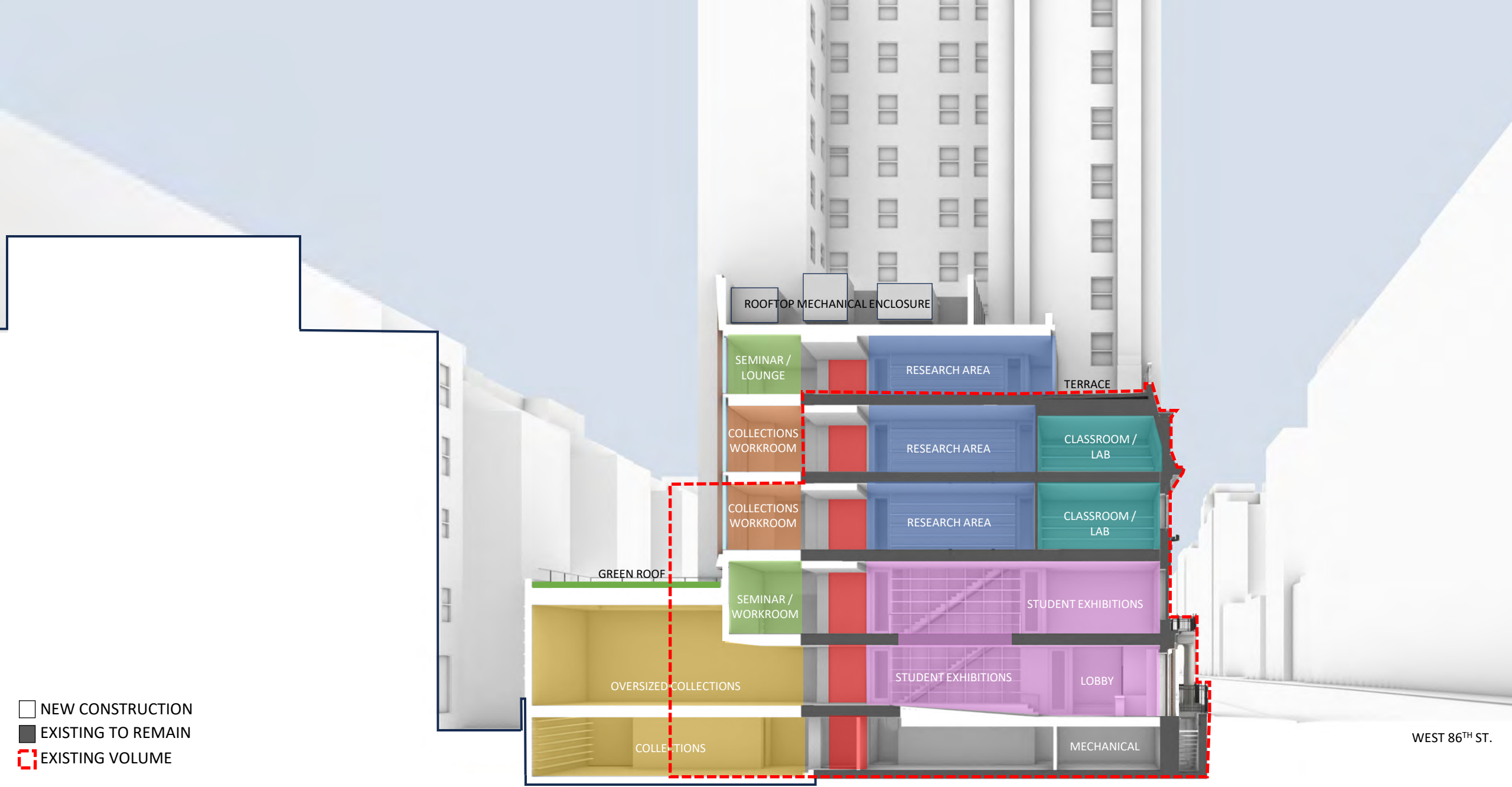

- NEW CONSTRUCTION
- EXISTING TO REMAIN
- EXISTING VOLUME

WEST 86<sup>TH</sup> ST.





VIEW LOOKING SOUTHWEST FROM WEST 86<sup>TH</sup> STREET



PROPOSED





SECTION PERSPECTIVE LOOKING WEST



PROPOSED



- NEW CONSTRUCTION
- EXISTING TO REMAIN
- EXISTING VOLUME

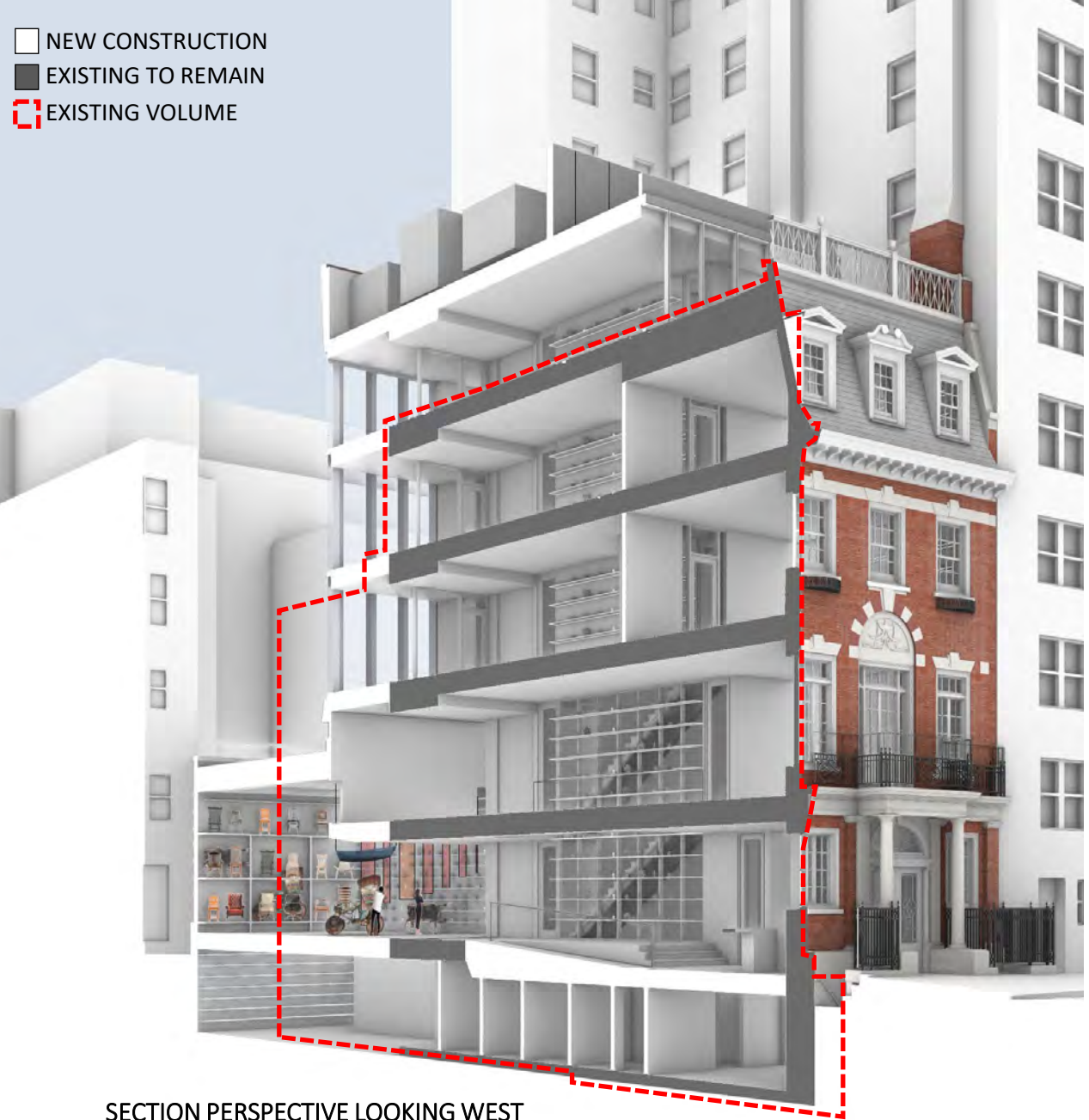

SECTION PERSPECTIVE LOOKING WEST



PROPOSED





HISTORICAL CONTEXT



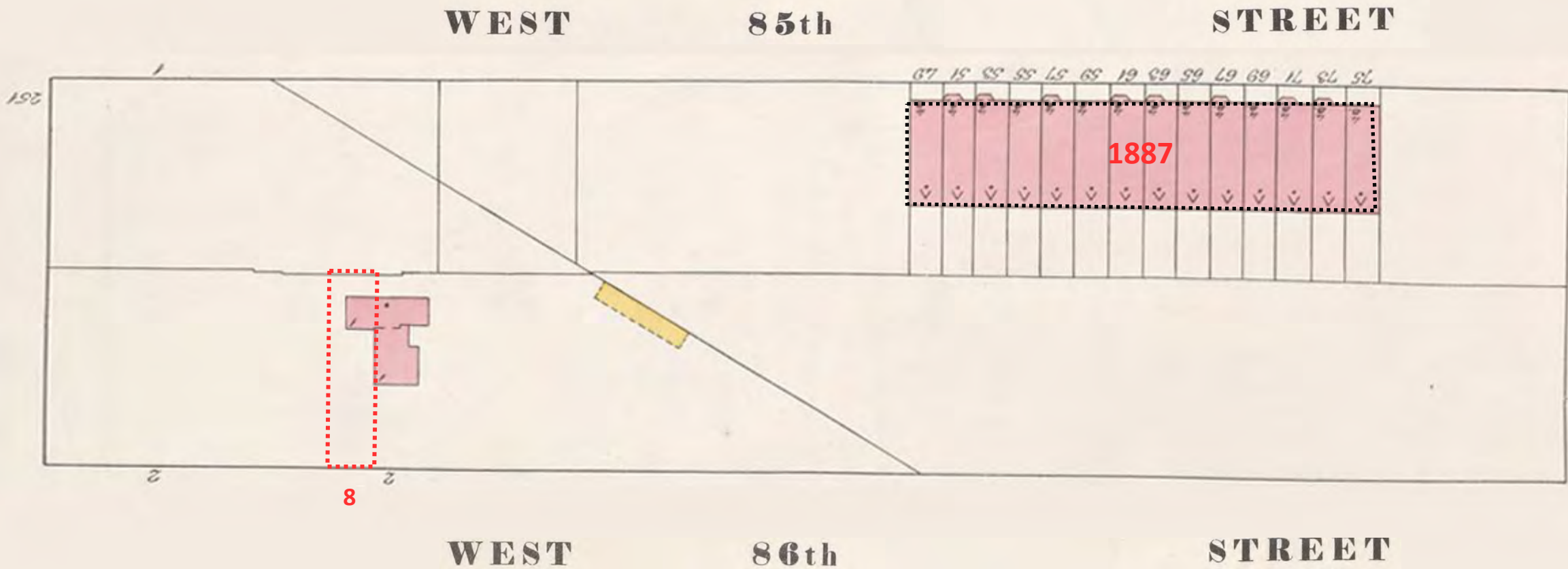

1902 Sanborn Fire Insurance Map









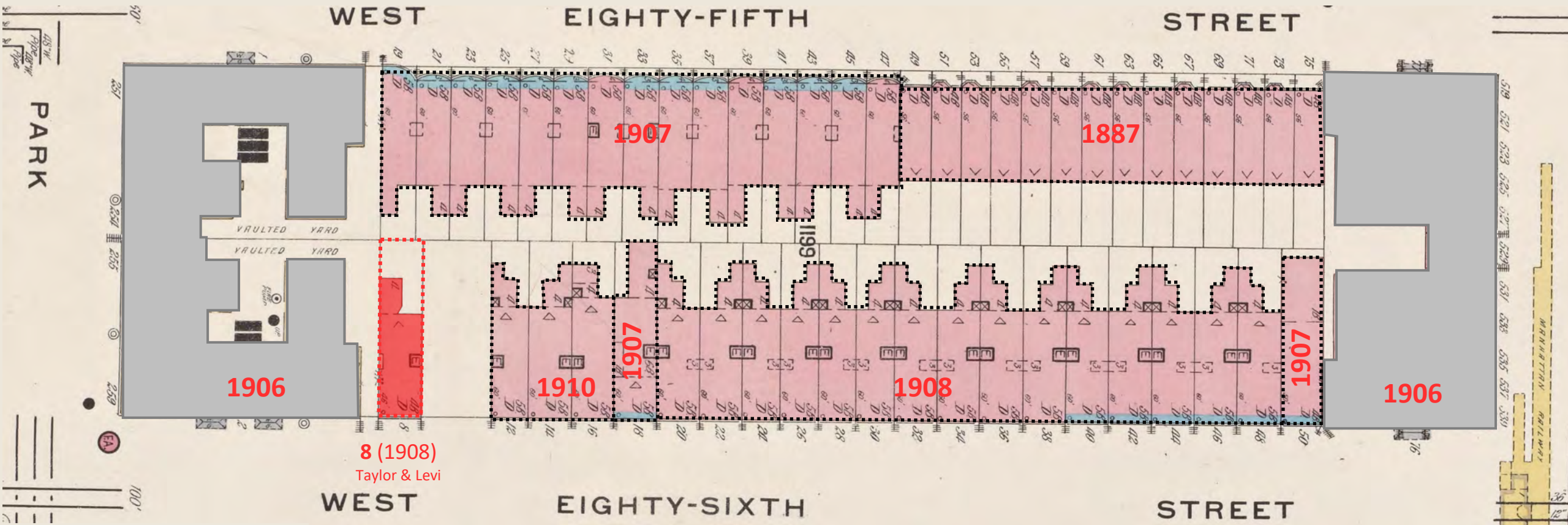

1912 Sanborn Fire Insurance Map

HISTORY OF 8 WEST 86<sup>TH</sup> | EVOLUTION OF THE BLOCK – 1908-1910





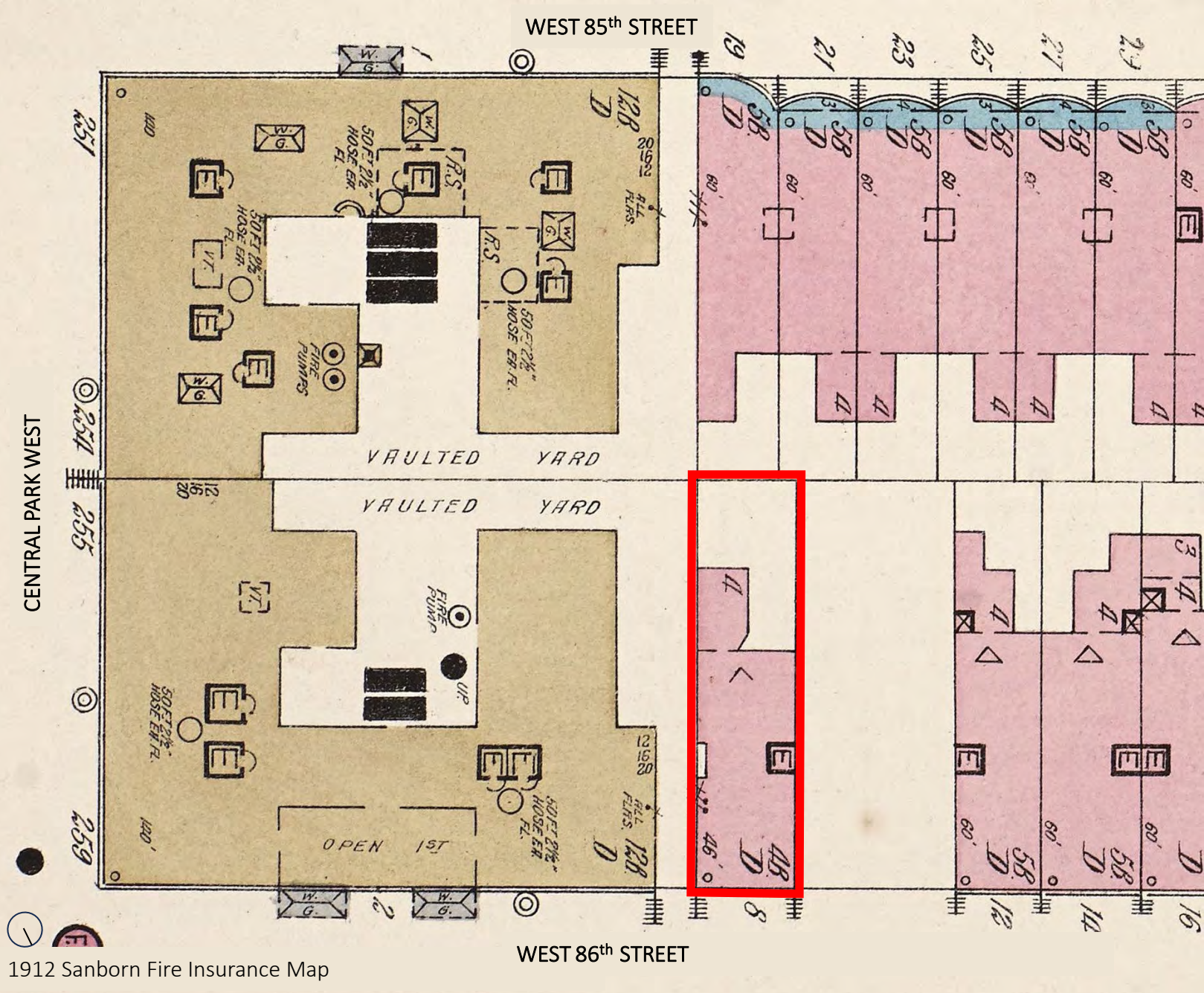

1908, Avery Library

1912 Sanborn Fire Insurance Map

HISTORY OF 8 WEST 86<sup>TH</sup> | DESIGNED BY TAYLOR & LEVI, BUILT 1908





1908, Avery Library

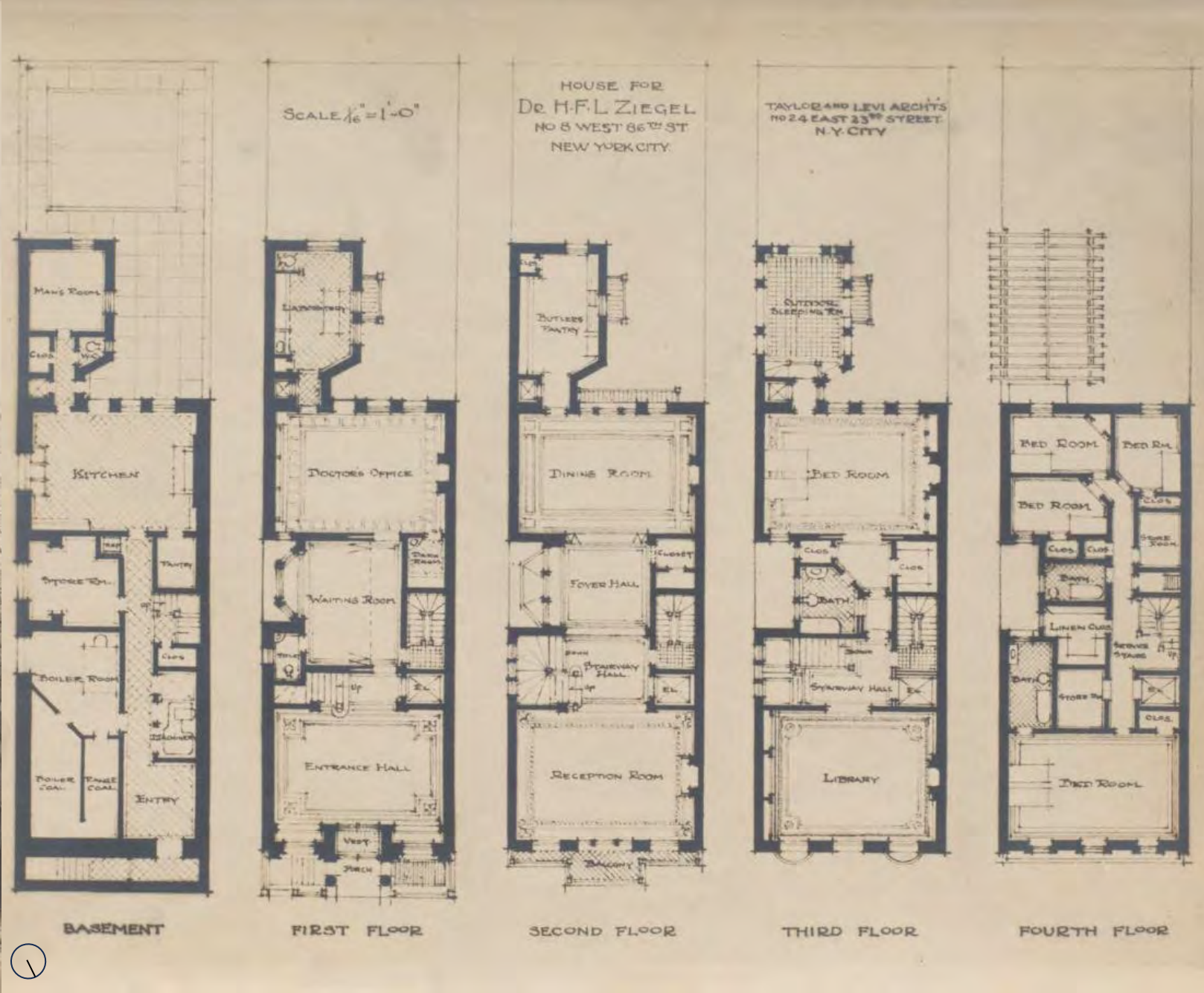





Martin Erdman House, 57 E 55<sup>th</sup> Street (1909)  
Individual landmark, designated 2016



32 E 70<sup>th</sup> Street (1914)  
UES Historic District, designated 1981



160 E 72<sup>nd</sup> Street (1928)  
UES Historic District, designated 2010





Tax photo, 1940



LPC Designation photo, 1990

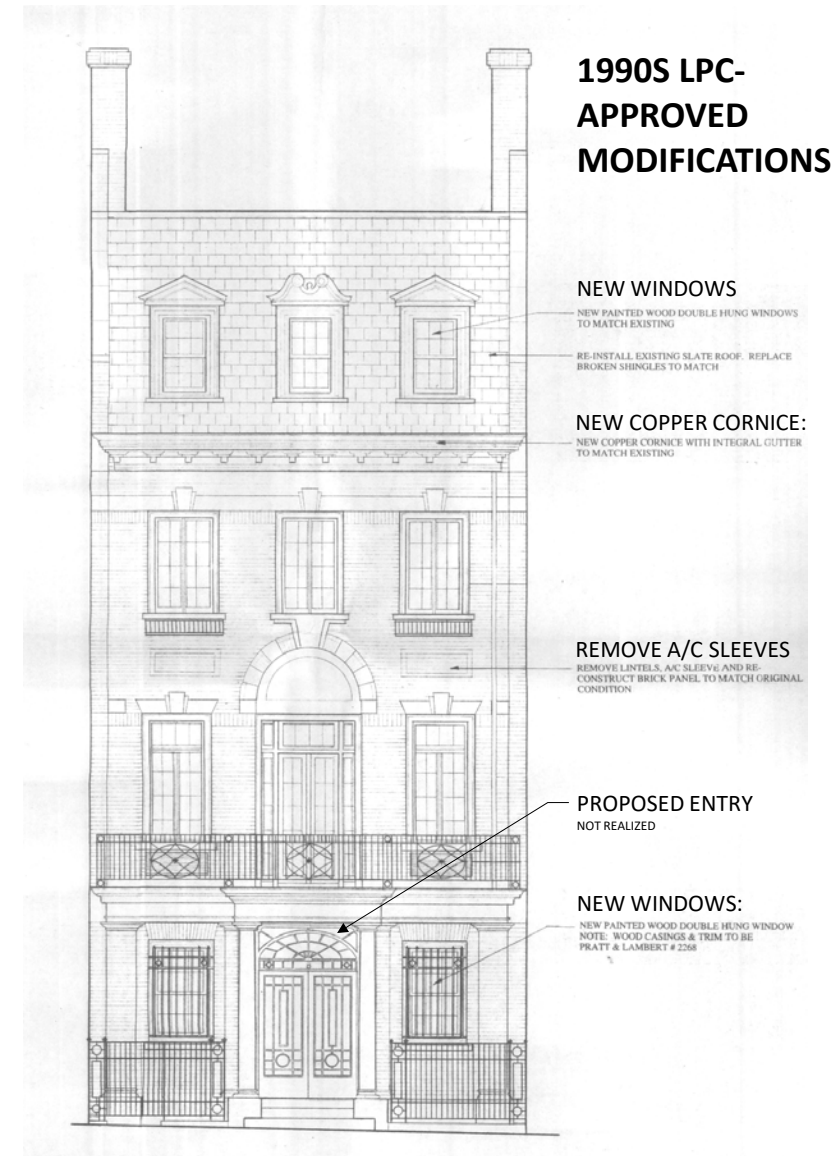

1996 proposed elevation (Platt Byard Dovell)







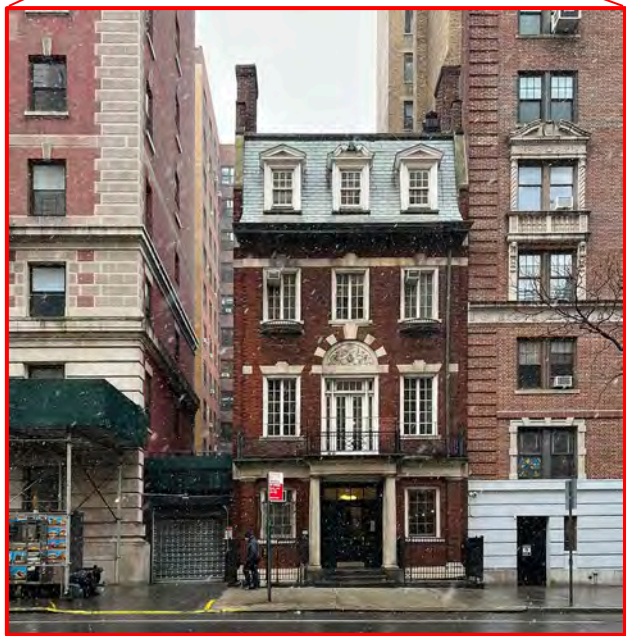

8 W 86<sup>TH</sup> STREET







**8** PROPOSED STUDY COLLECTIONS

1908, architect: Taylor and Levi



**18** GALLERY / ADMINISTRATION

1907, architect: Buchman and Fox



**36/38** ACADEMICS / LIBRARY / PUBLIC PROGRAM

1908, architect: Welch, Smith and Provot



WEST 85<sup>TH</sup> STREET

STORIES

- 1
- 2
- 3
- 4
- 5
- 6
- 7
- 8+

CENTRAL PARK WEST

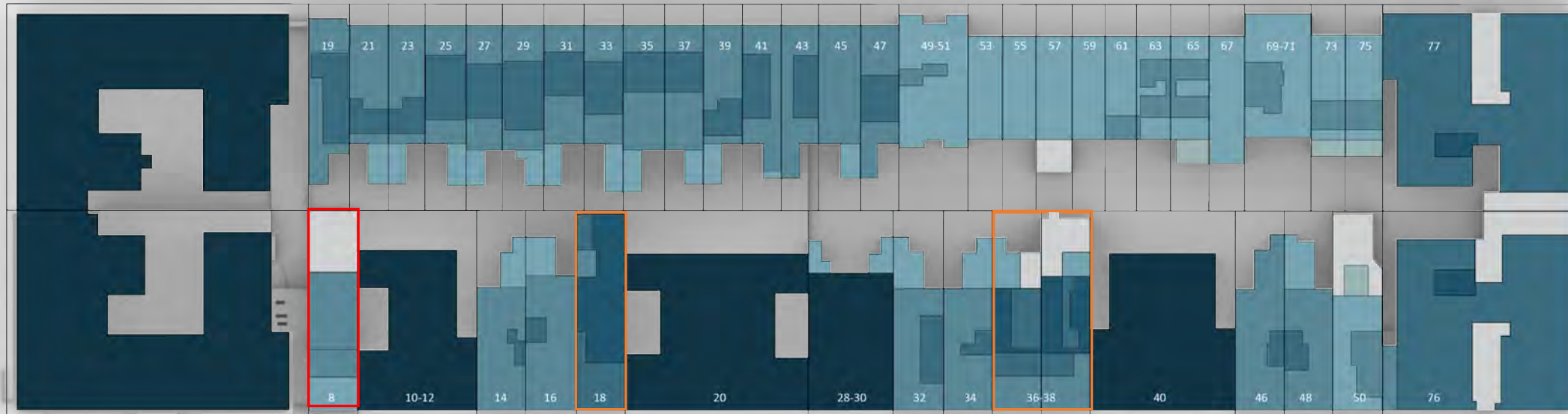

WEST 86<sup>TH</sup> STREET

8

18

36 - 38

COLUMBUS AVENUE

**18 WEST 86<sup>TH</sup> STREET**

LPC Approved Rear & Rooftop Additions:

- 1995
- (Spector Group)



**36-38 WEST 86<sup>TH</sup> STREET**

LPC Approved Rear & Rooftop Additions:

- 38 - 1998
  - 36 - 2008
- (Polshek Partnership)





**36-38 WEST 86<sup>TH</sup> STREET**

LPC Approved Rear & Rooftop Additions:

- 38 - 1998
- 36 - 2008

(Polshek Partnership)







Goethe Institute, 1014 5<sup>th</sup> Avenue (David Chipperfield Architects, Paratus Group, Karo Architects, LPC-approved 2022)

Friends Seminary, 216-222 East 16th Street (Kilment Halsband Architects, LPC-approved 2006)

Spence School, 56 East 93rd Street (PBDW, LPC-approved 2003)





PROPOSED DESIGN | TRANSFORMING 8 WEST 86<sup>TH</sup> STREET TO HOUSE THE BGC STUDY COLLECTION





## SLATE ROOF / DORMERS

- Replace missing slate tiles
- Repair wood trim at windows and restore dormers



## WOOD

- Repair wood trim at all windows on north facade



## LIMESTONE

- Repair cracks and remove stains on limestone at north and east facades



## BRICK

- Replace damaged or non-historic bricks as needed and repoint throughout





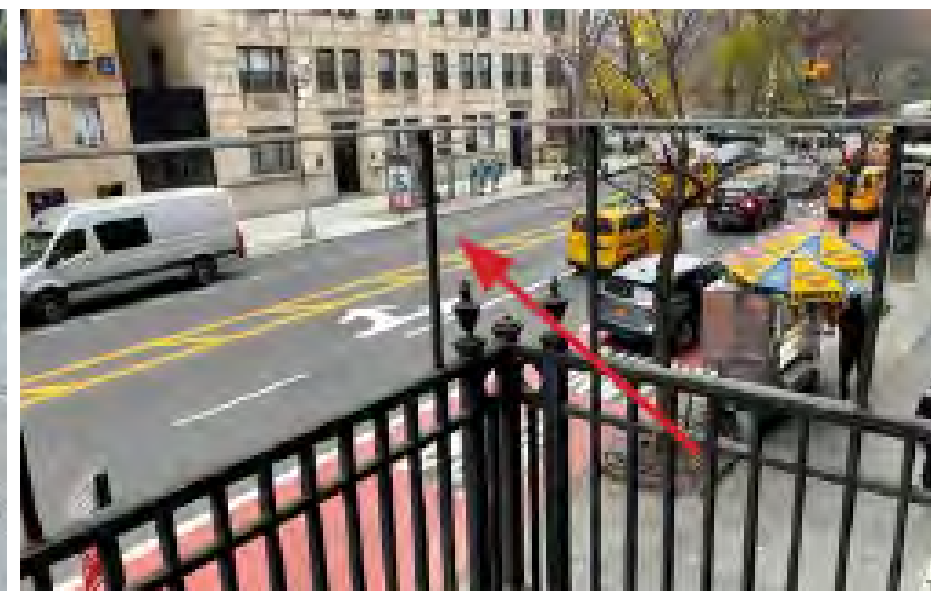





1908, Avery Library



EXISTING WINDOWS

**Bard Graduate Center** RESTORATION SCOPE | WINDOW REPLACEMENT TO ORIGINAL CONFIGURATION





1908, Avery Library







Hollins House, 12 West 56<sup>th</sup> Street  
McKim, Mead & White, 1901  
(Individual Landmark)



George F. Baker, Jr. House, 75 East 93<sup>rd</sup> Street  
Delano & Aldrich, 1918. North addition, 1928.  
(Individual Landmark)



Knickerbocker Club, 2 East 62<sup>nd</sup> Street  
Delano & Aldrich, 1915.  
(Individual Landmark)





NON-CODE COMPLIANT STAIR AND EGRESS ROUTE

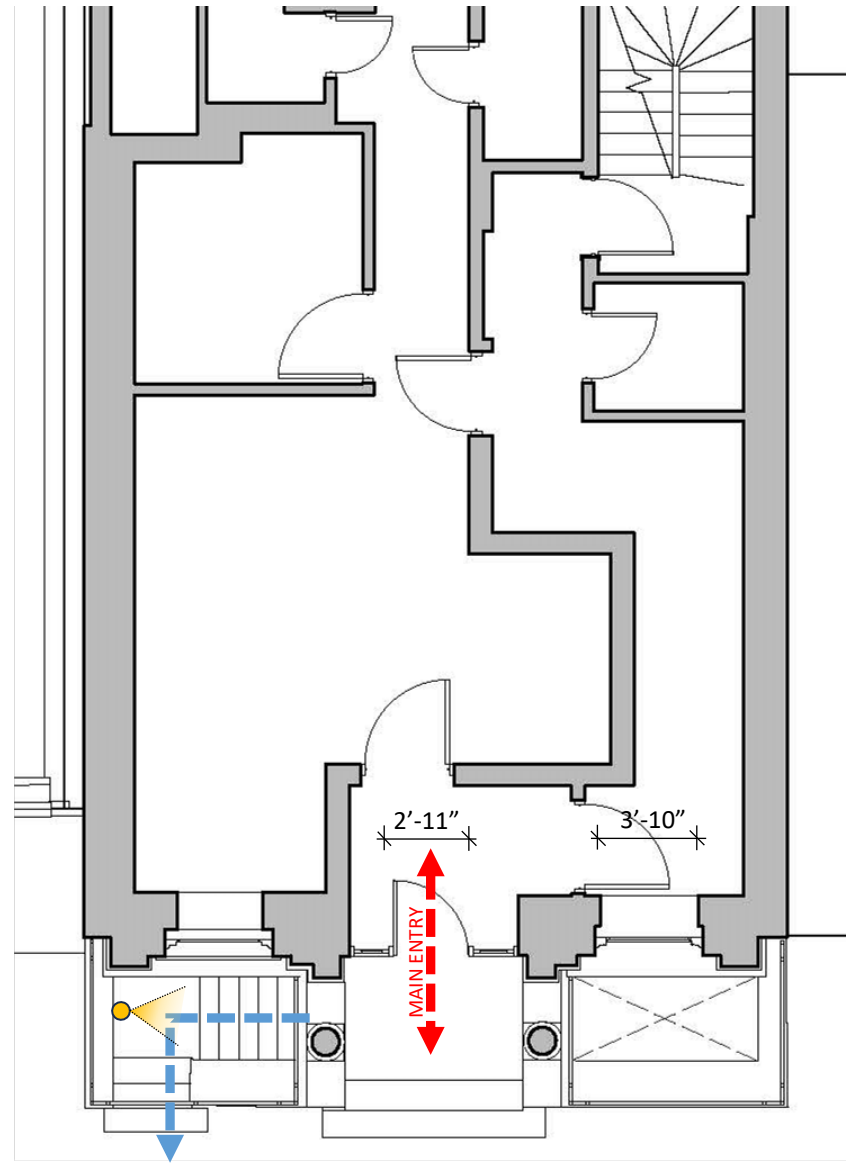

EXISTING

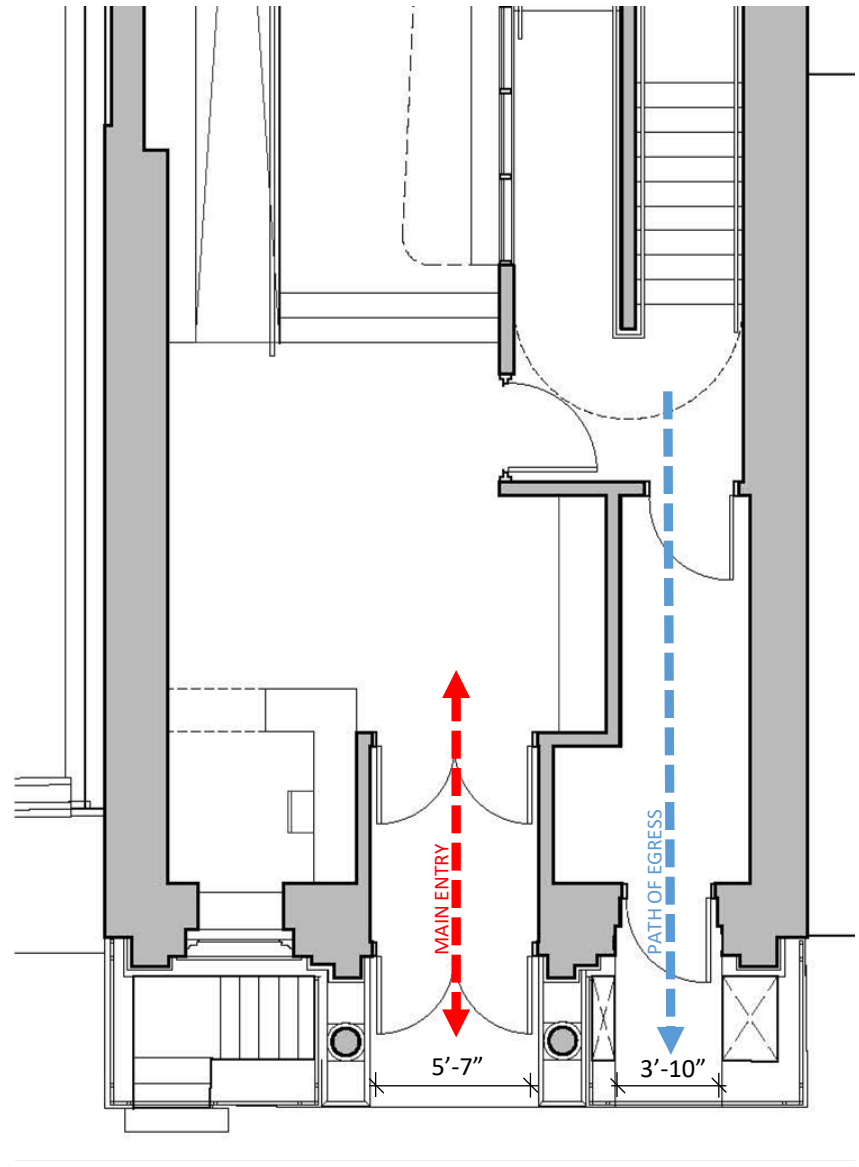

PROPOSED

EXISTING AREAWAY STAIR





EXISTING FRONT DOOR

EXISTING

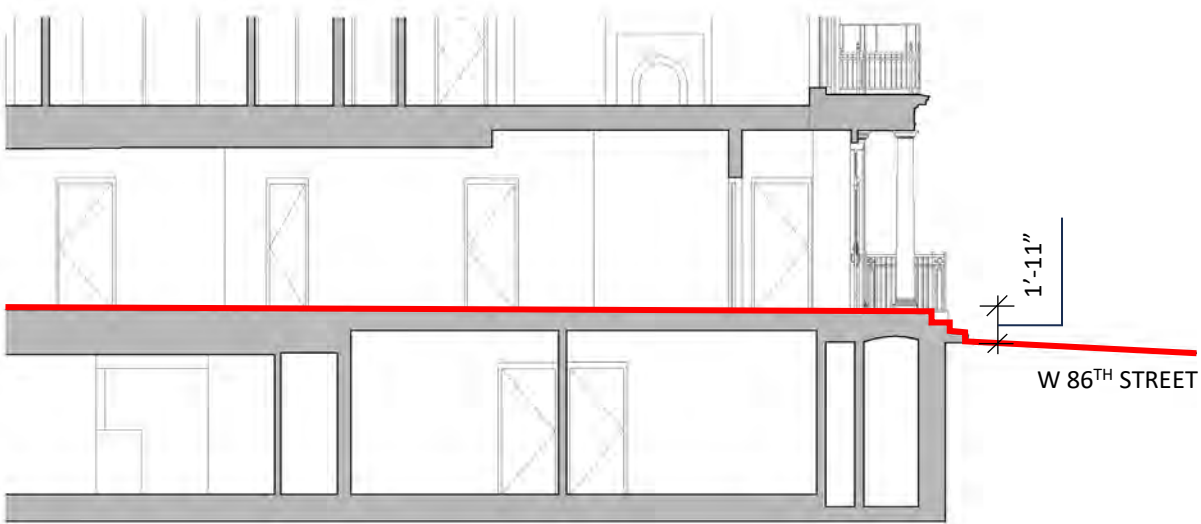

EXISTING SECTION THROUGH ENTRANCE

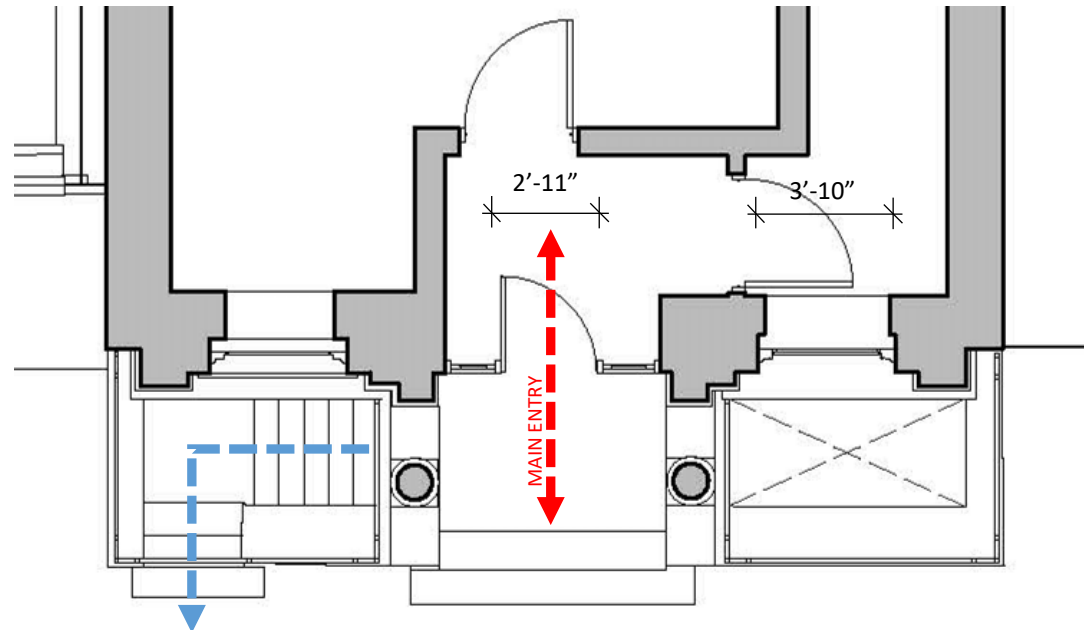

EXISTING 1<sup>ST</sup> FLOOR PLAN

W 86<sup>TH</sup> STREET





1908, AVERY LIBRARY

PROPOSED

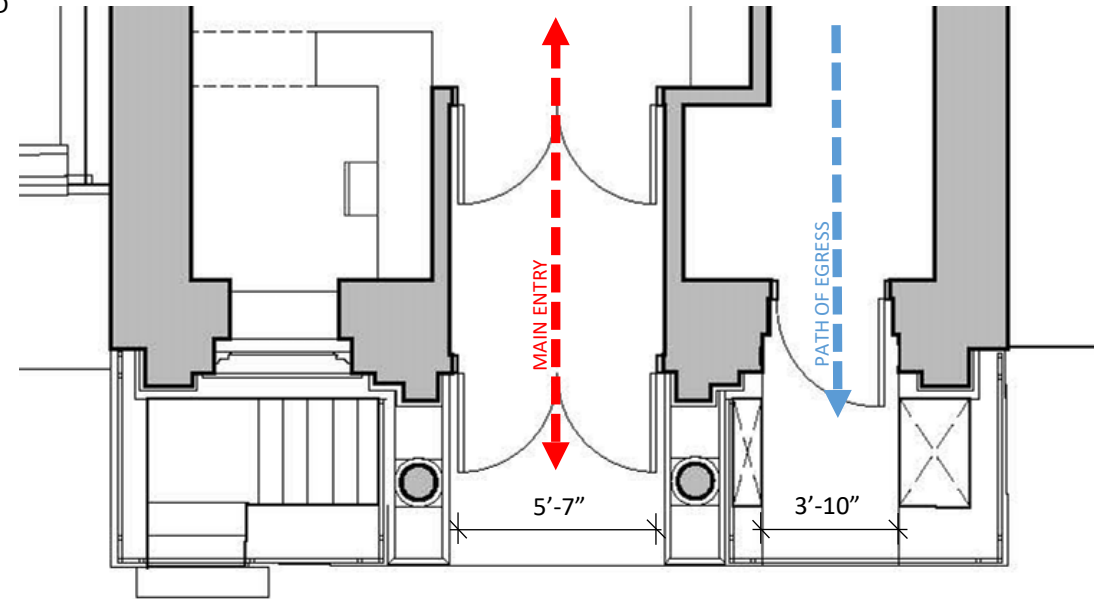
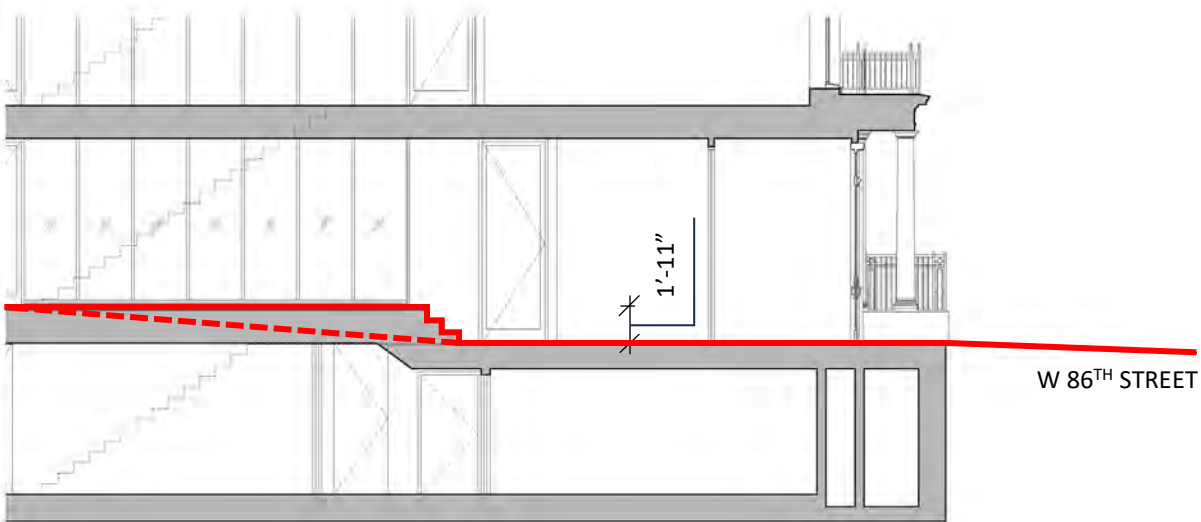

PROPOSED SECTION THROUGH ENTRANCE

PROPOSED 1<sup>ST</sup> FLOOR PLAN

W 86<sup>TH</sup> STREET





EXISTING



PROPOSED



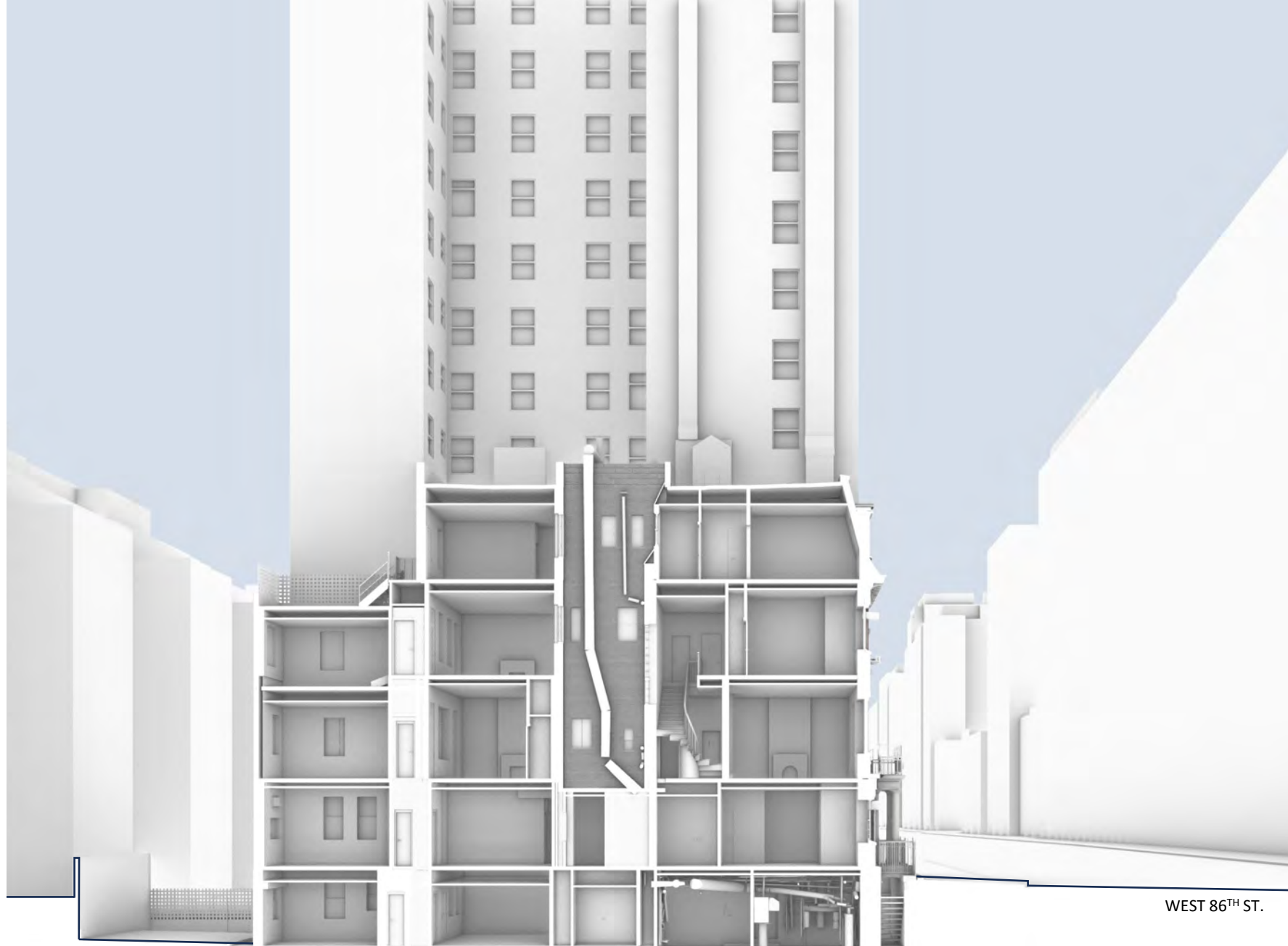
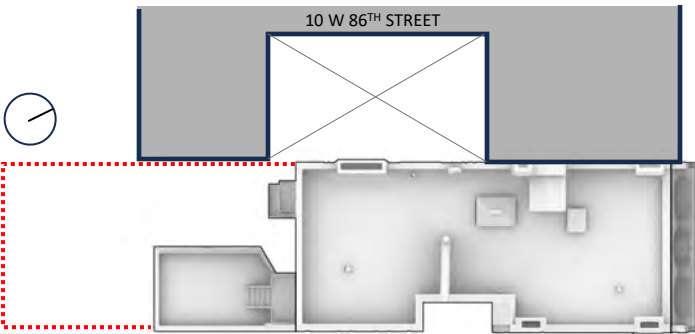

WEST 86<sup>TH</sup> ST.





SERVICE ALLEY LOOKING NORTH

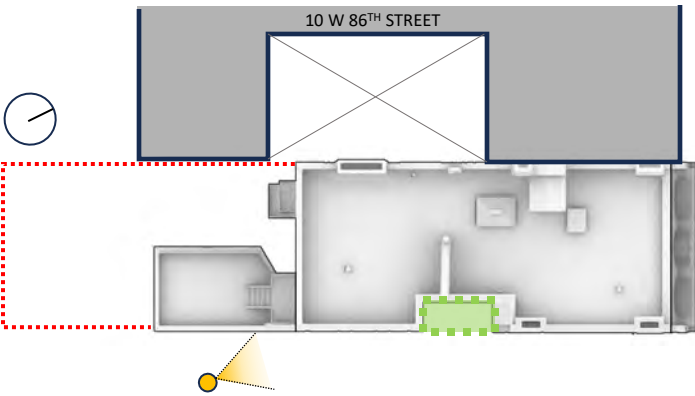

WEST 86<sup>TH</sup> ST.





REAR YARD LOOKING NORTH

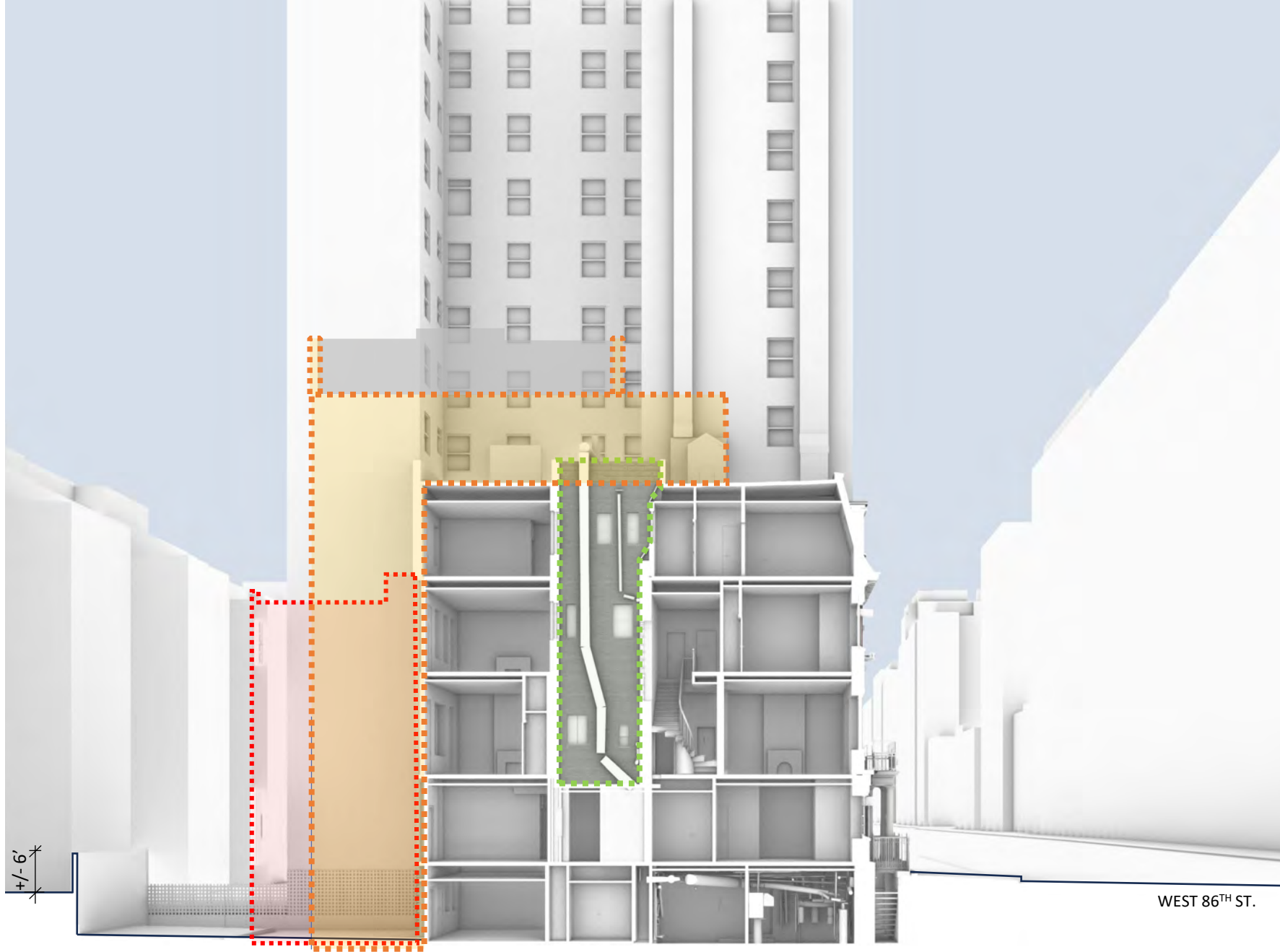
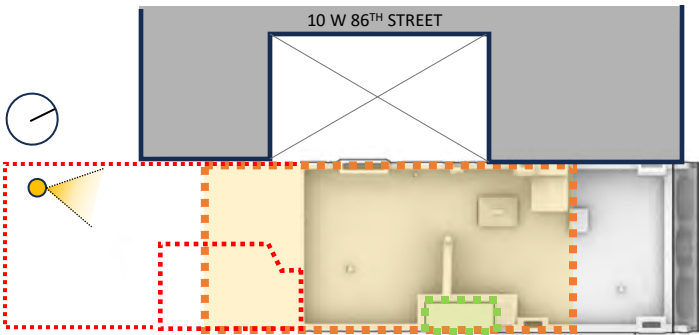

WEST 86TH ST.





REAR YARD LOOKING SOUTH FROM 3<sup>RD</sup> FLOOR

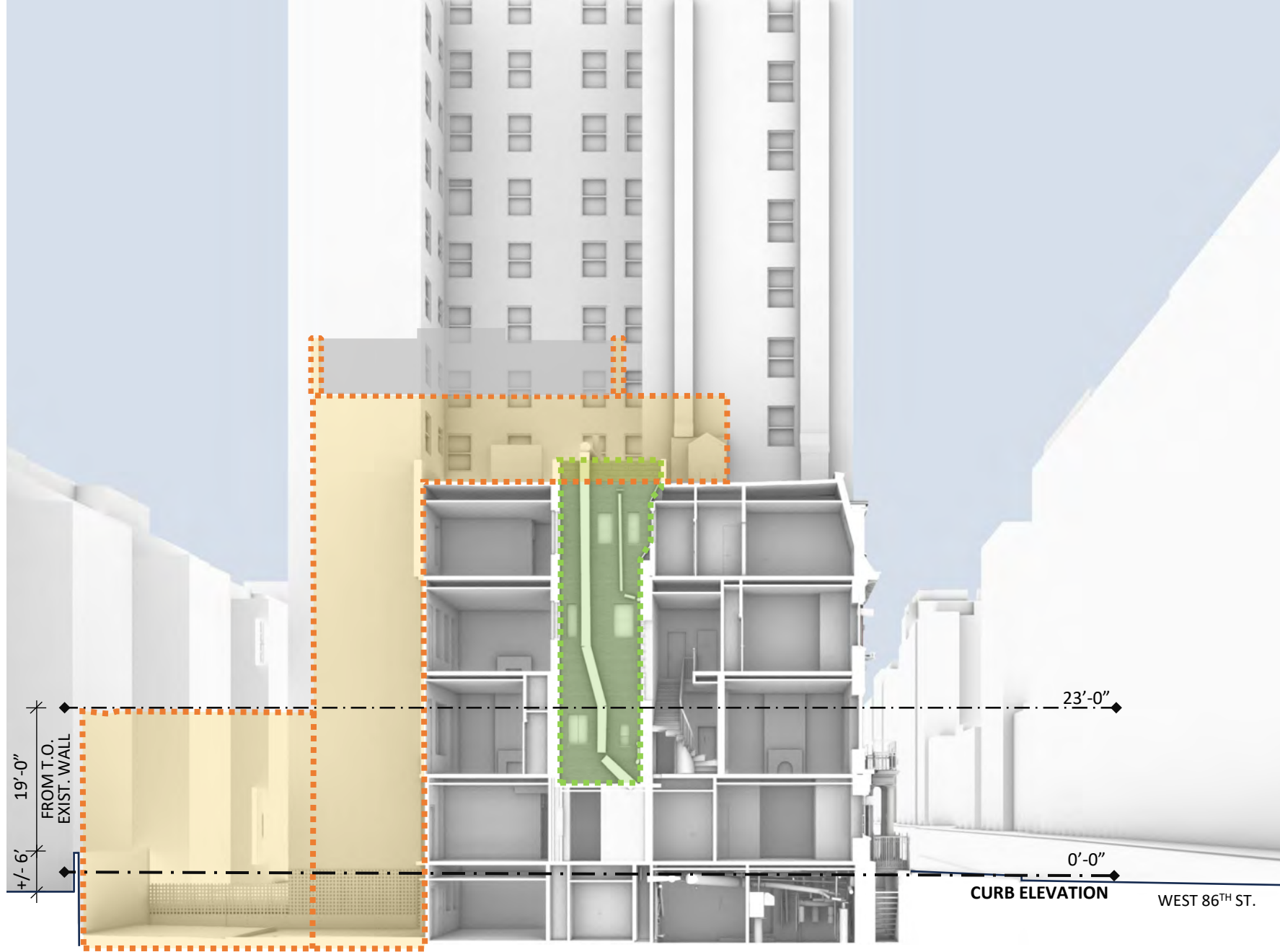
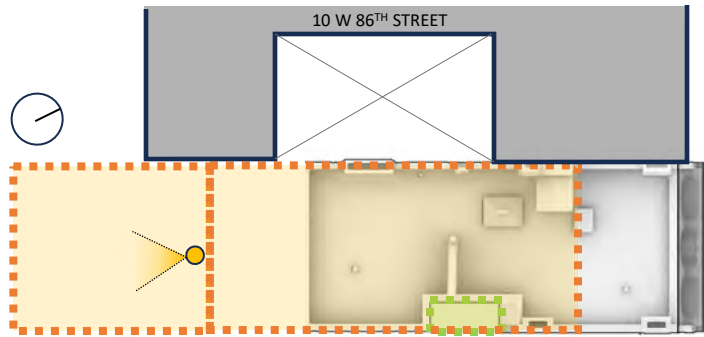



**AS OF RIGHT CONSTRUCTION**

- 70% Lot Coverage
- 23' High Rear Yard Expansion w/ Green Roof
- Single-Story Rooftop Addition
- Rooftop Mechanical w/ Enclosure Screen

**EXISTING: 8,110 GFA, FAR 3.19**

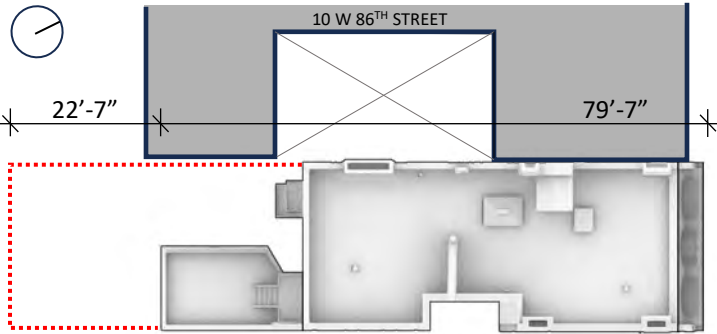

**PROPOSED: 11,915 GFA, FAR 3.53 (allowable FAR, 10)**

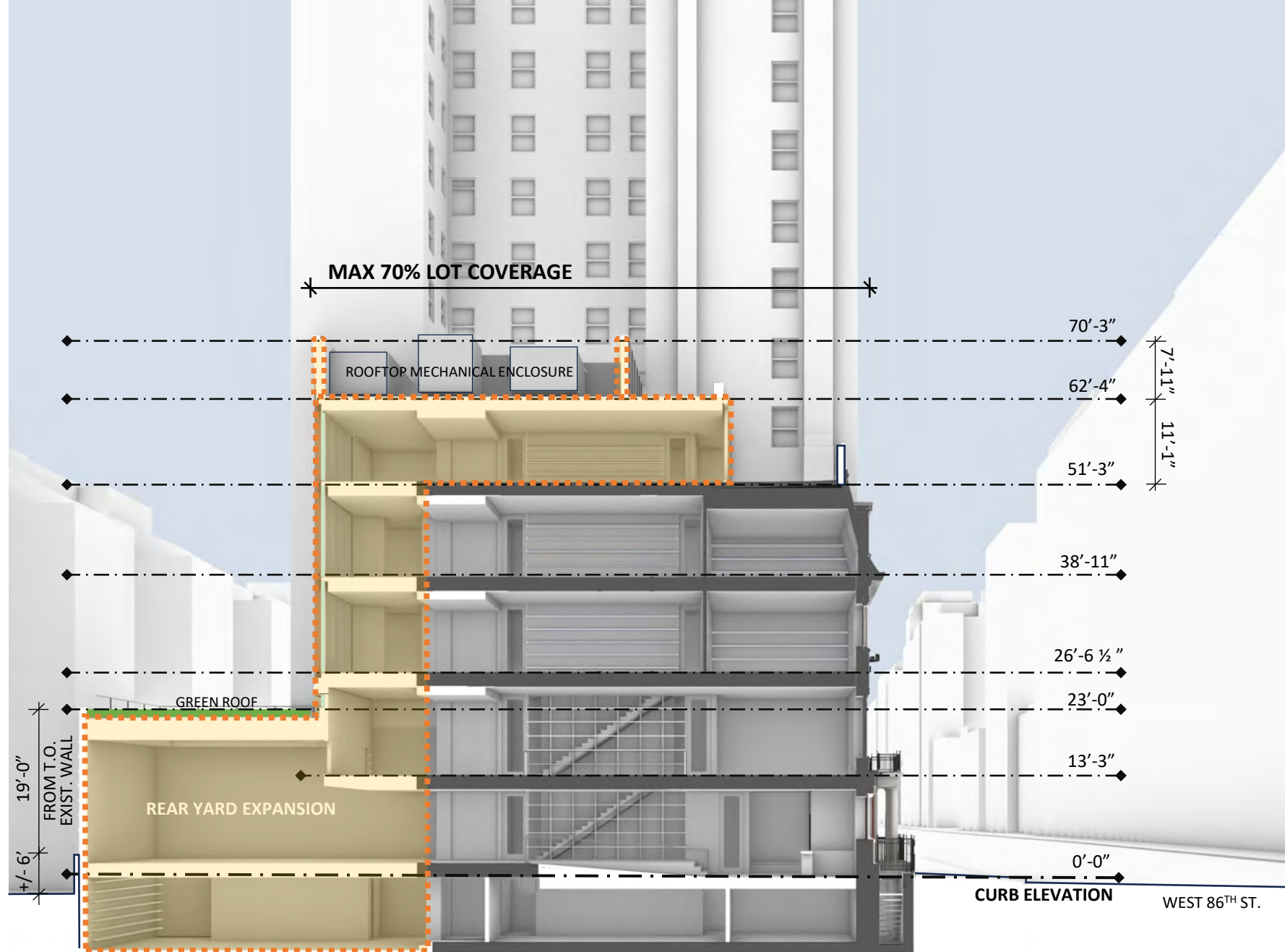
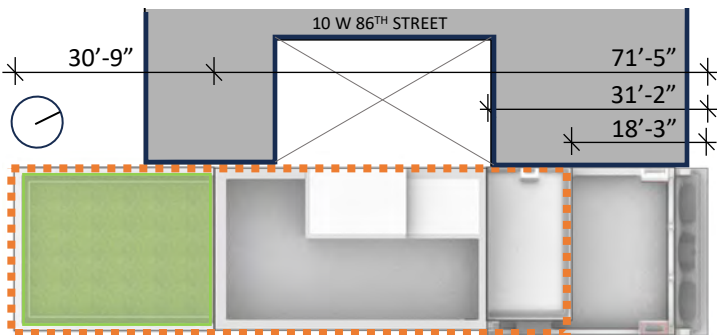

□ NEW CONSTRUCTION  
 ■ EXISTING TO REMAIN



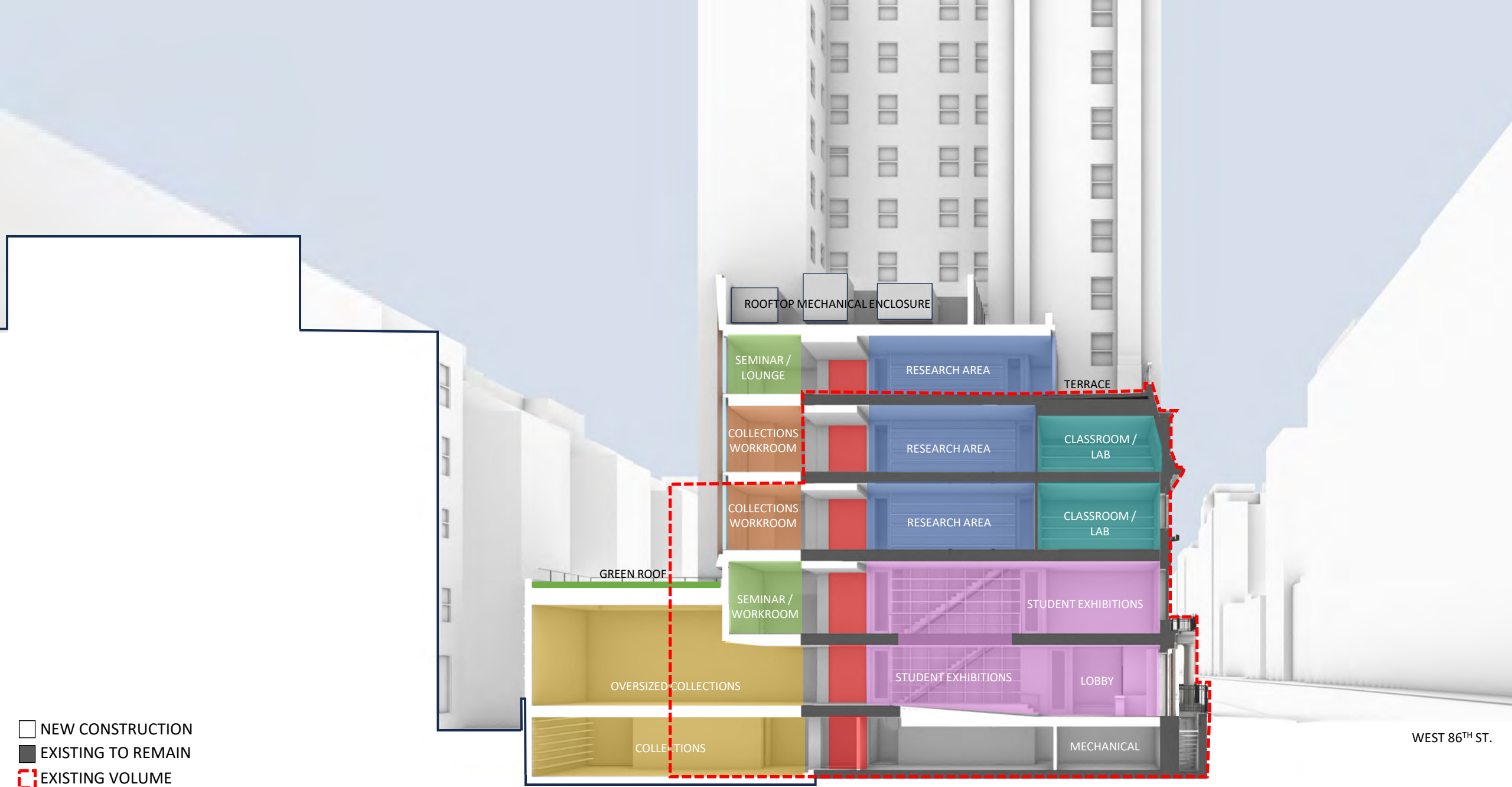

- NEW CONSTRUCTION
- EXISTING TO REMAIN
- EXISTING VOLUME

WEST 86<sup>TH</sup> ST.





## PROGRAM OF SPACES

- Lobby/Student Exhibitions/Security
- Collections
- Collection Workrooms/Staff
- Research Spaces
- Classrooms/Labs
- Student Gathering/Study Spaces
- Building Support

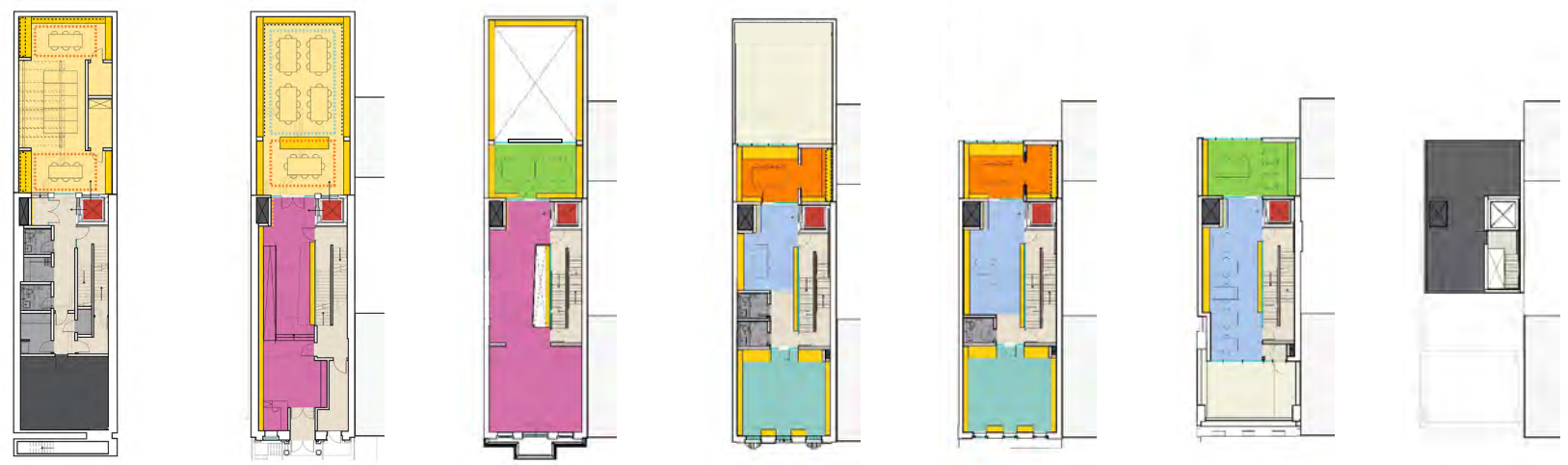

CELLAR      1      2      3      4      5      BULKHEAD





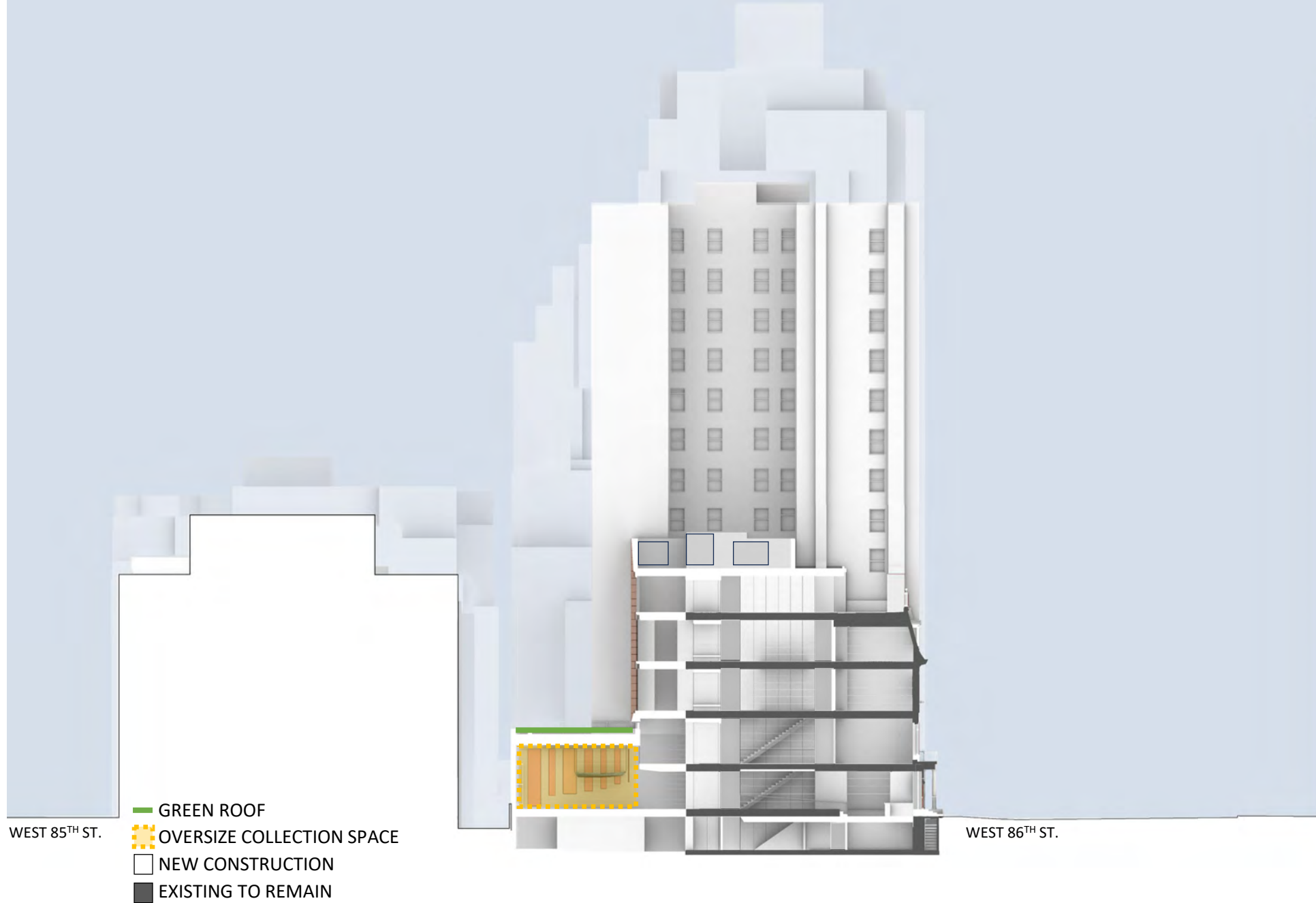



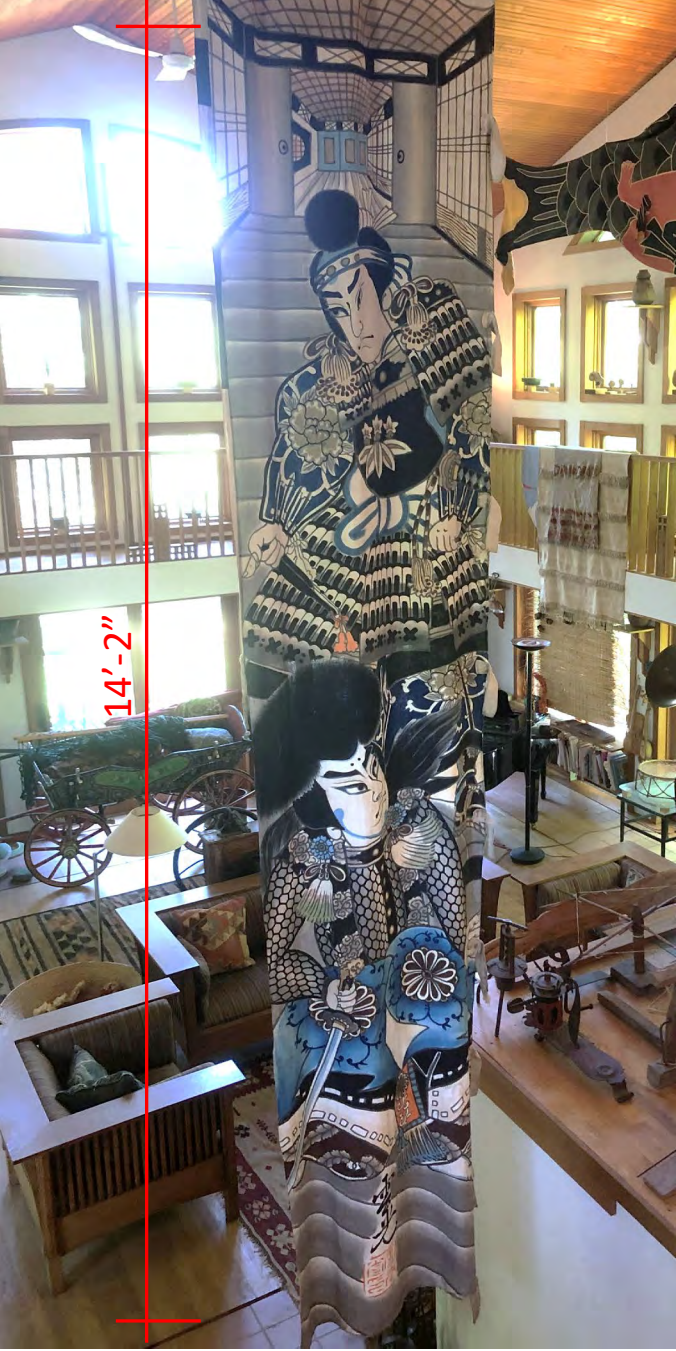

14'-2"

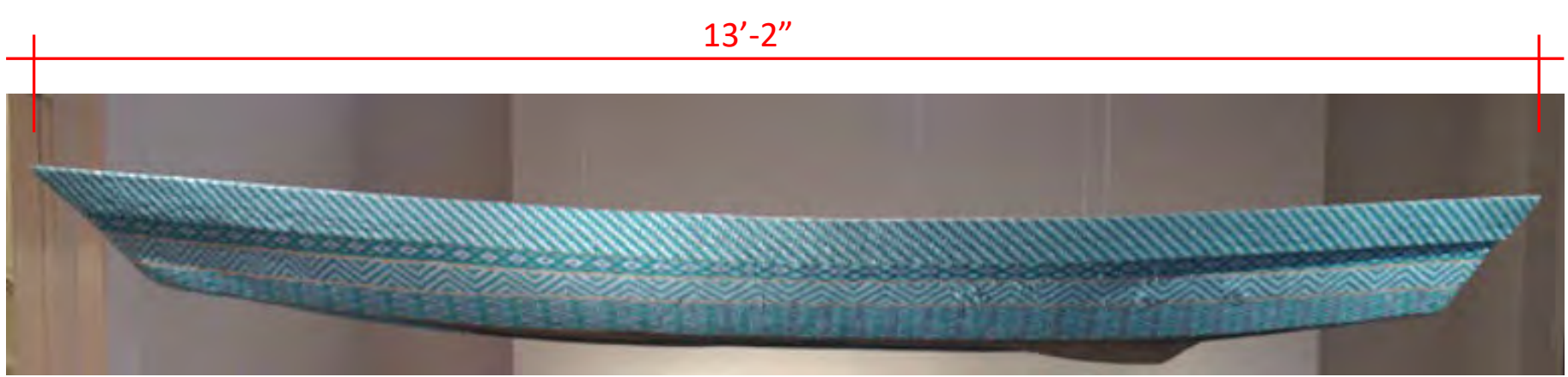

13'-2"

Inga (Canoe): 11" wide, 29 1/2" long



9'-0"

Bell Collection in Woodstock



Mongolian Ger: Approx. 12' diameter, 9' tall



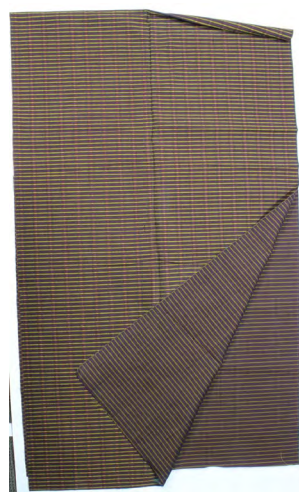
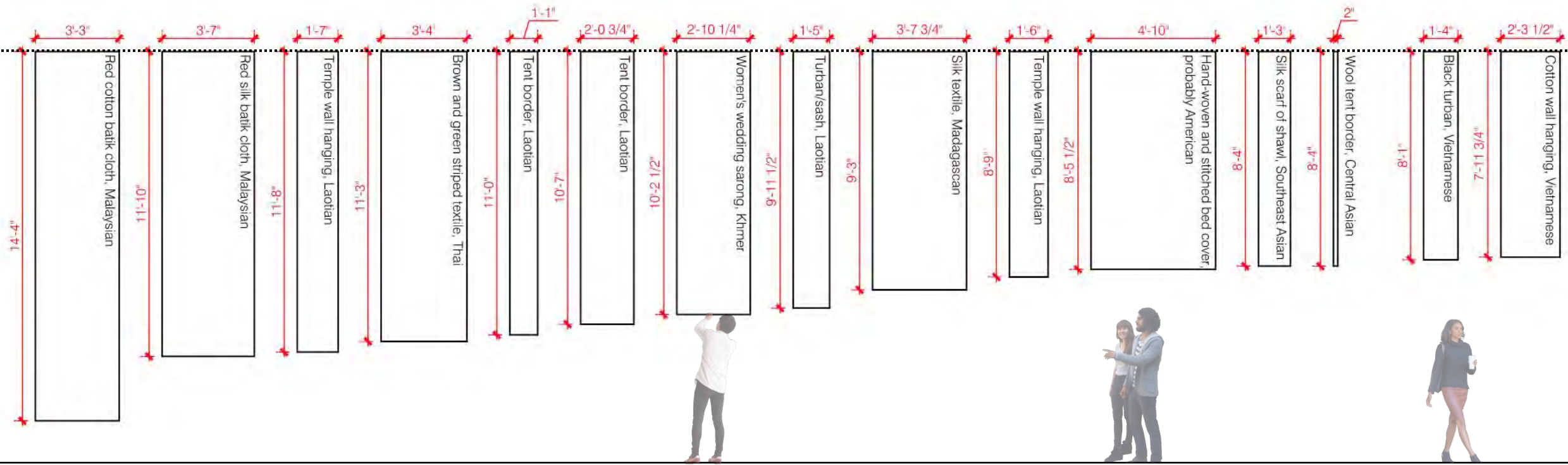

Oversize textiles from the BGC Study Collection







STORIES

- 1
- 2
- 3
- 4
- 5
- 6
- 7
- 8+

WEST 85<sup>TH</sup> STREET



WEST 86<sup>TH</sup> STREET

CENTRAL PARK WEST



VIEW OF REAR YARD AND SERVICE DRIVE LOOKING SOUTH FROM 3<sup>RD</sup> FLOOR





STORIES

- 1
- 2
- 3
- 4
- 5
- 6
- 7
- 8+

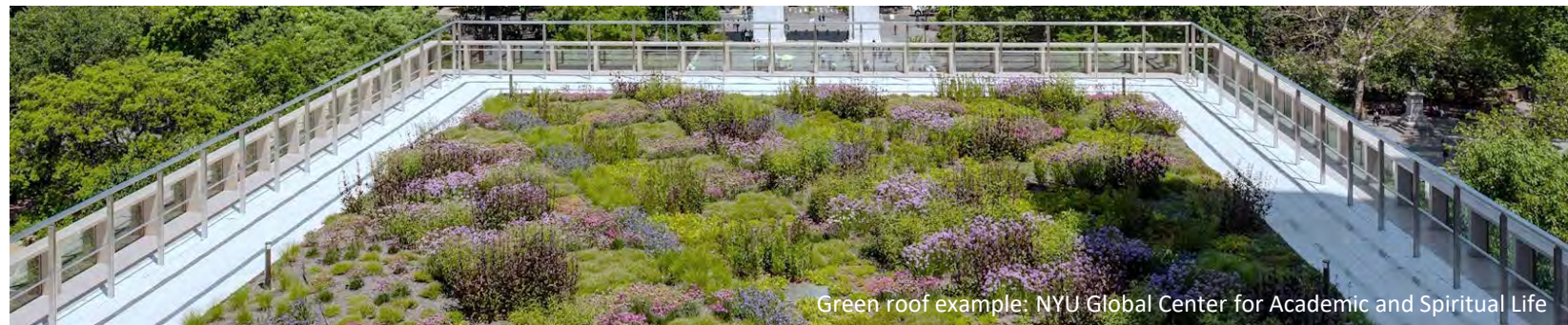

Green roof example: NYU Global Center for Academic and Spiritual Life











SOUTH (REAR)



EAST (SIDE)



NORTH (FRONT)



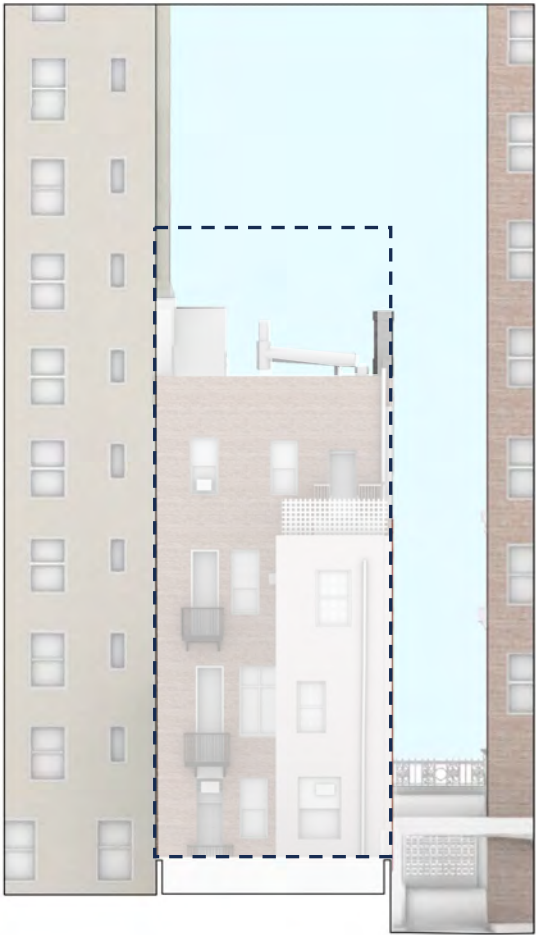

SOUTH (REAR)

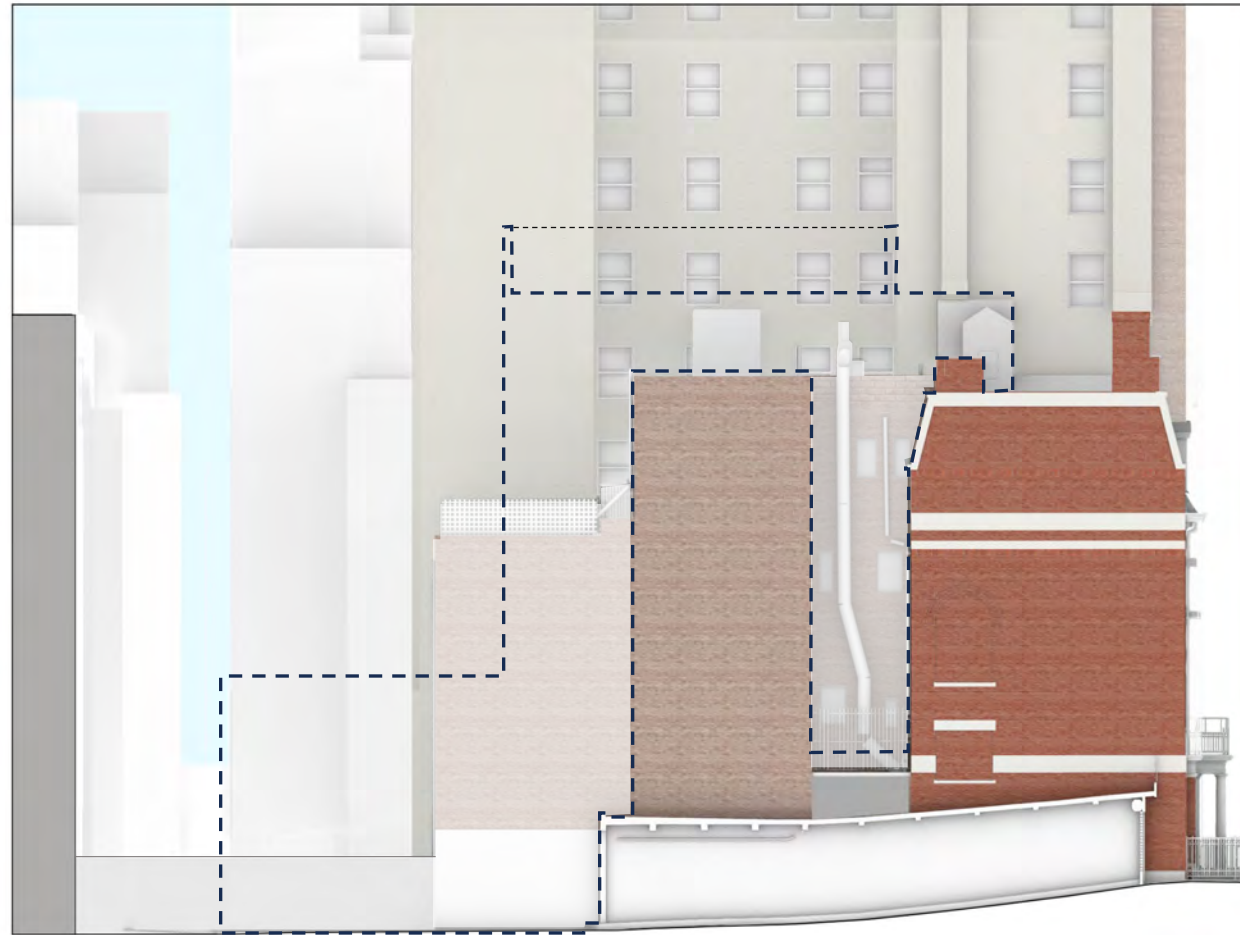

EAST (SIDE)

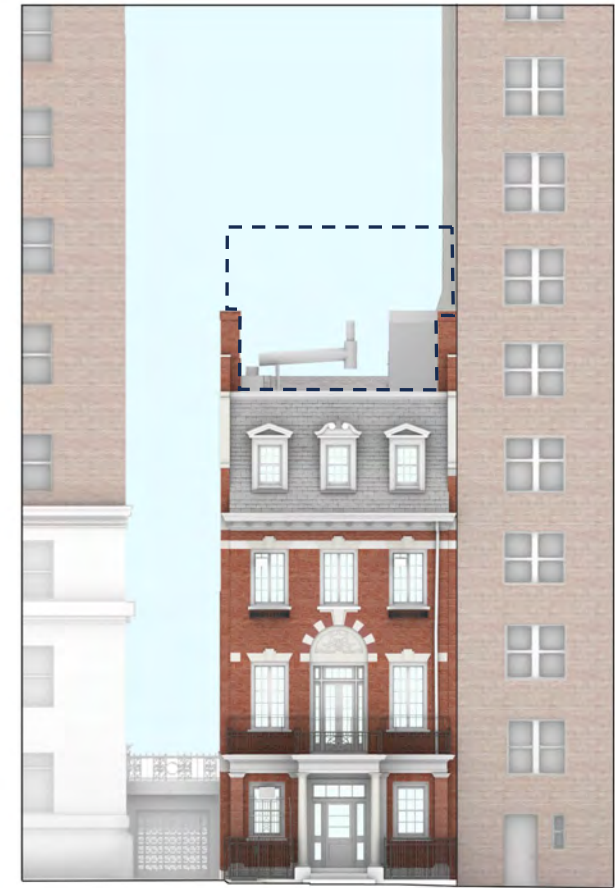

NORTH (FRONT)



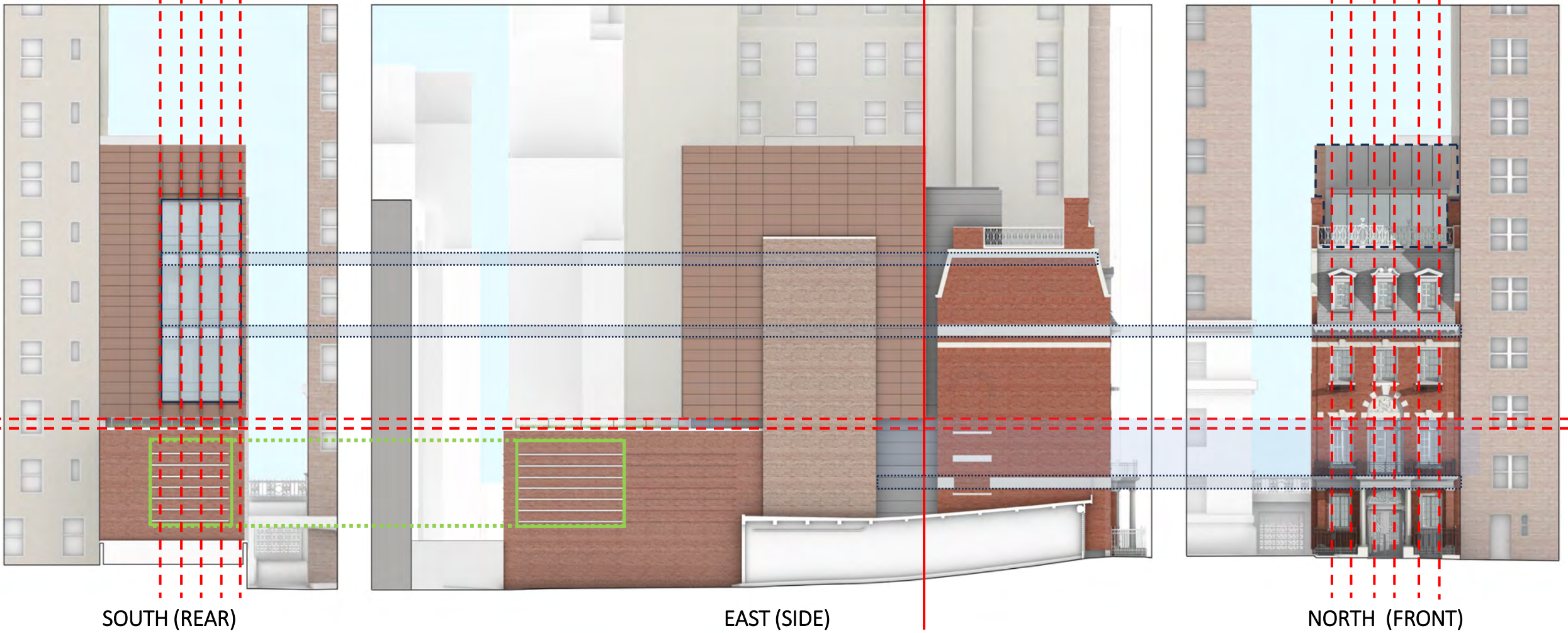





SOUTH (REAR)



EAST (SIDE)



NORTH (FRONT)



1: ZINC

2: TERRACOTTA

3: BRICK

4: EXISTING COMMON BRICK

5: EXISTING ORNAMENTAL BRICK





EXISTING SOUTH (REAR)

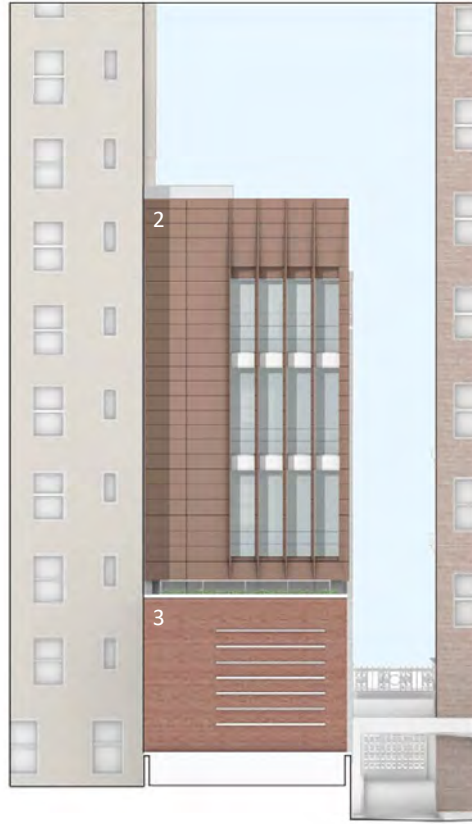

PROPOSED SOUTH (REAR)



EXISTING NORTH (FRONT)



PROPOSED NORTH (FRONT)

- ◆ 70'-3"  
MECHANICAL ENCLOSURE
- ◆ 62'-4"  
ROOFTOP ADDITION
- ◆ 51'-3"  
EXISTING ROOF



1: ZINC

2: TERRACOTTA

3: BRICK

4: EXISTING-COMMON BRICK

5: EXISTING ORNAMENTAL BRICK





EXISTING EAST (SIDE)



PROPOSED EAST (SIDE)

- ◆ 70'-3"  
MECHANICAL ENCLOSURE
- ◆ 62'-4"  
ROOFTOP ADDITION
- ◆ 51'-3"  
EXISTING ROOF



1: ZINC

2: TERRACOTTA

3: BRICK

4: EXISTING-COMMON BRICK

5: EXISTING ORNAMENTAL BRICK



# Streetscapes/Mulliken & Moeller, Architects; Upper West Side Designs in Brick and Terra Cotta

Share full article

By Christopher Gray

Sept. 14, 2003

THE architectural firm of Mulliken & Moeller, little known today, produced an unusually vigorous series of brick and terra cotta Upper West Side apartment buildings, including two notable pairs - on Amsterdam Avenue from 72nd to 73rd and Central Park West from 85th to 86th. All four early 1900's buildings have had recent restoration work that has brought attention to the long-forgotten partnership.

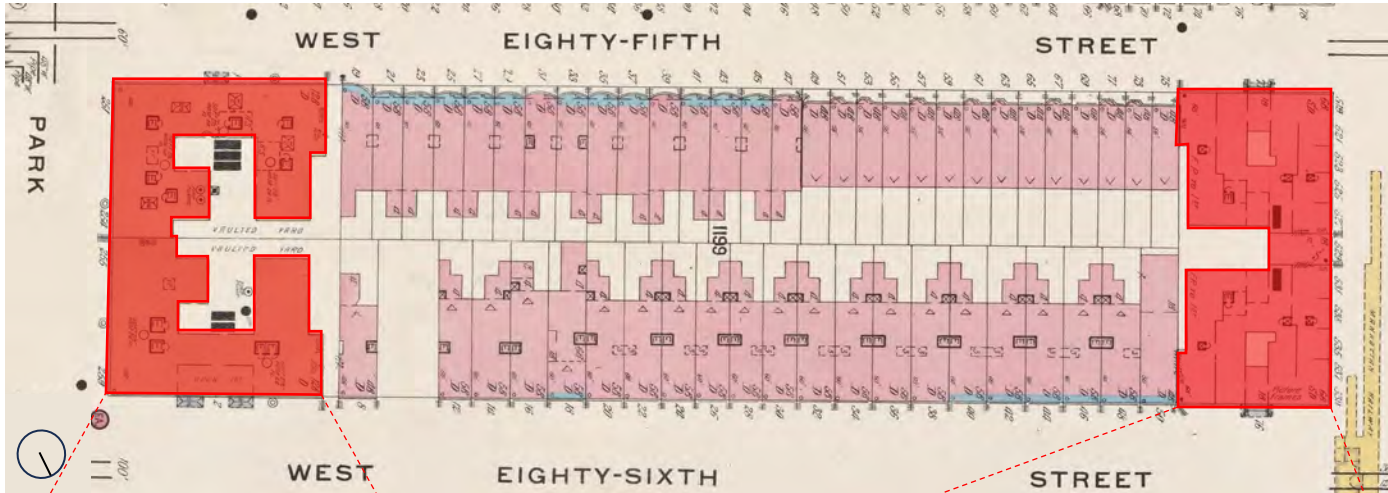





252 West 75th Street



111 57th Street, Shop Architects (2021)



200 11th Ave, Selldorf Architects (2010)



10 Bond Street, Selldorf Architects (2016)



Museum of Arts and Design, Allied Works (2008)



One Madison Gatehouse, BSK (2017)



**STORIES**

- 1
- 2
- 3
- 4
- 5
- 6
- 7
- 8+

CENTRAL PARK WEST

WEST 85<sup>TH</sup> STREET

COLUMBUS AVENUE

WEST 86<sup>TH</sup> STREET

+/-17'

+/-70'





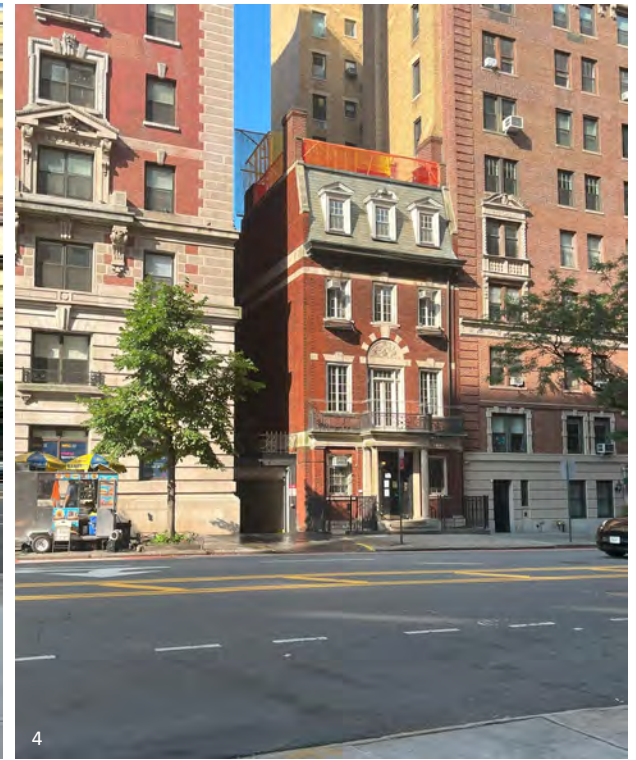

- PROPOSED BALUSTRADE
- 5<sup>TH</sup> FLOOR ADDITION
- MECHANICAL ENCLOSURE







- PROPOSED BALUSTRADE
- 5<sup>TH</sup> FLOOR ADDITION
- MECHANICAL ENCLOSURE

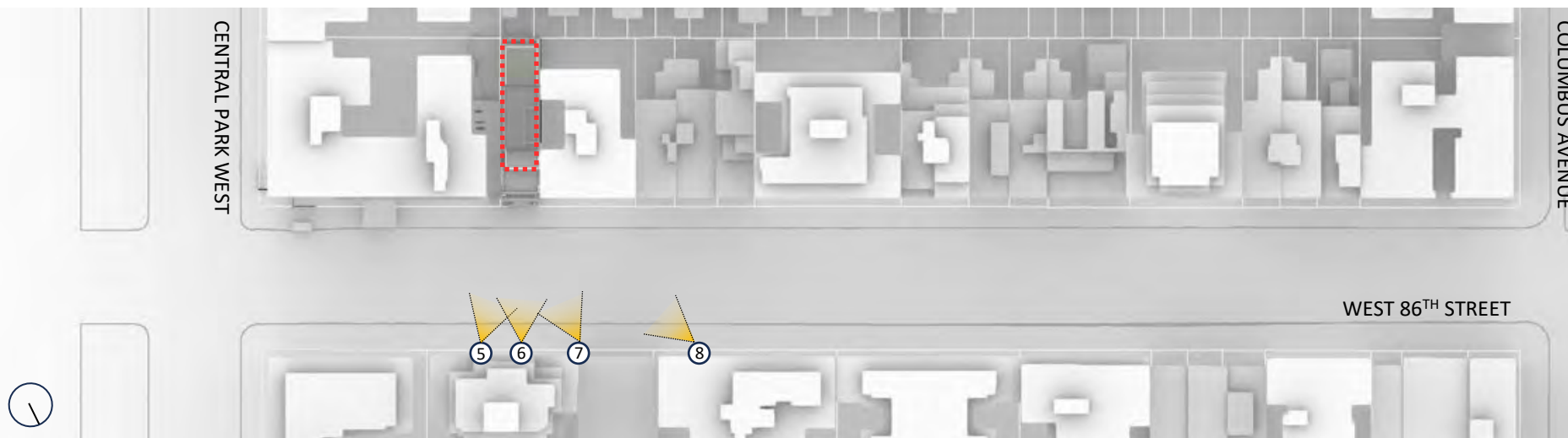



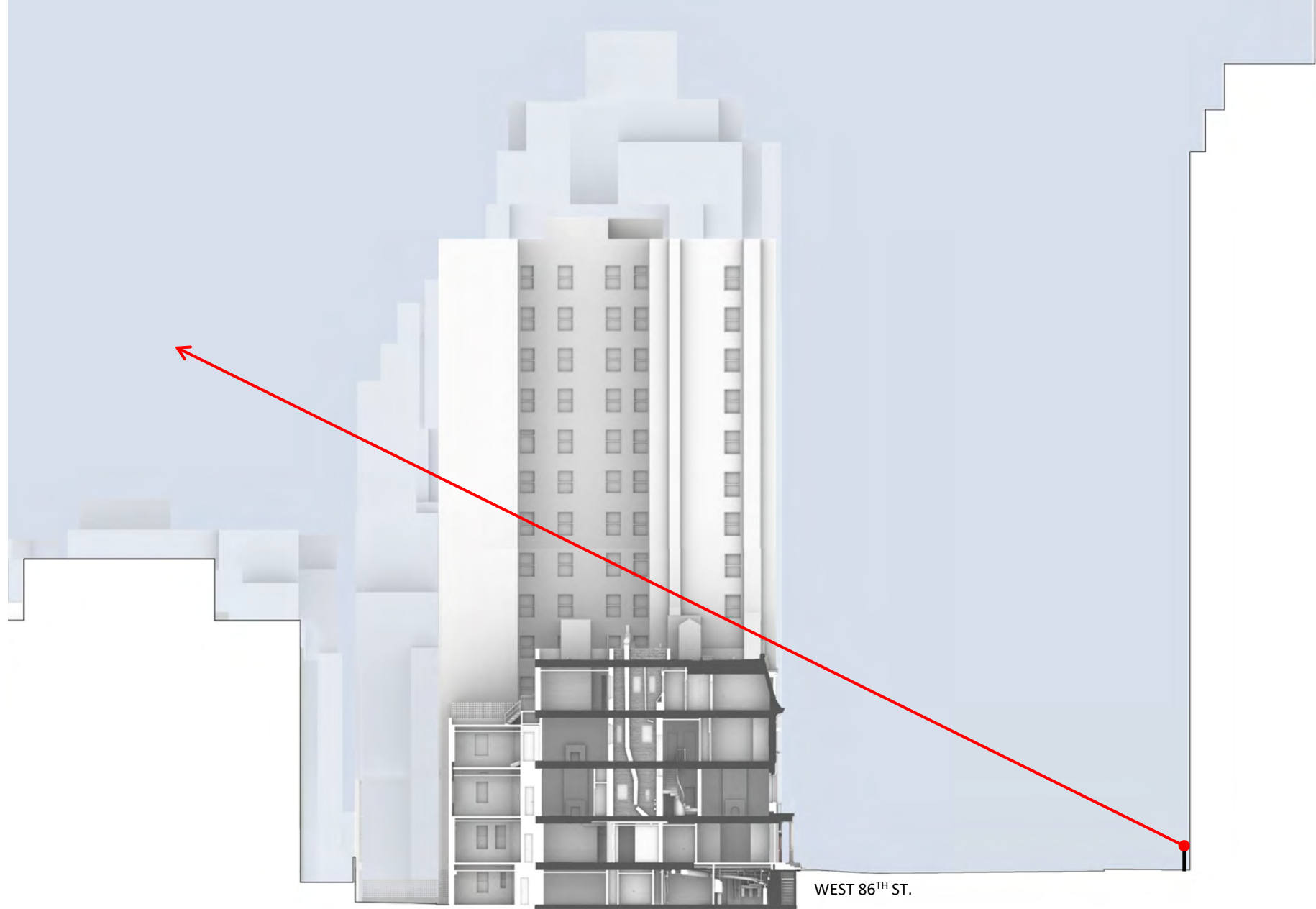



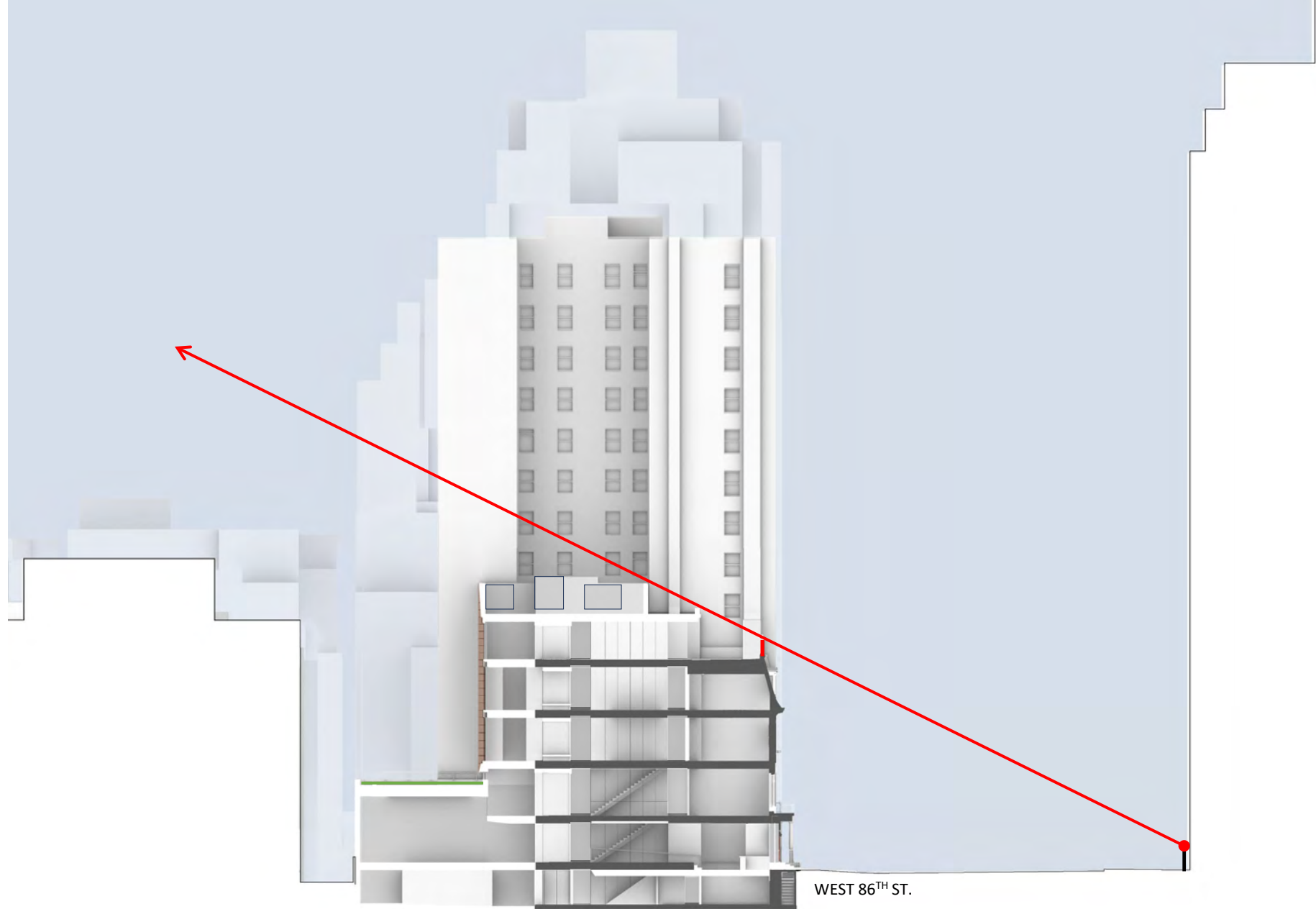



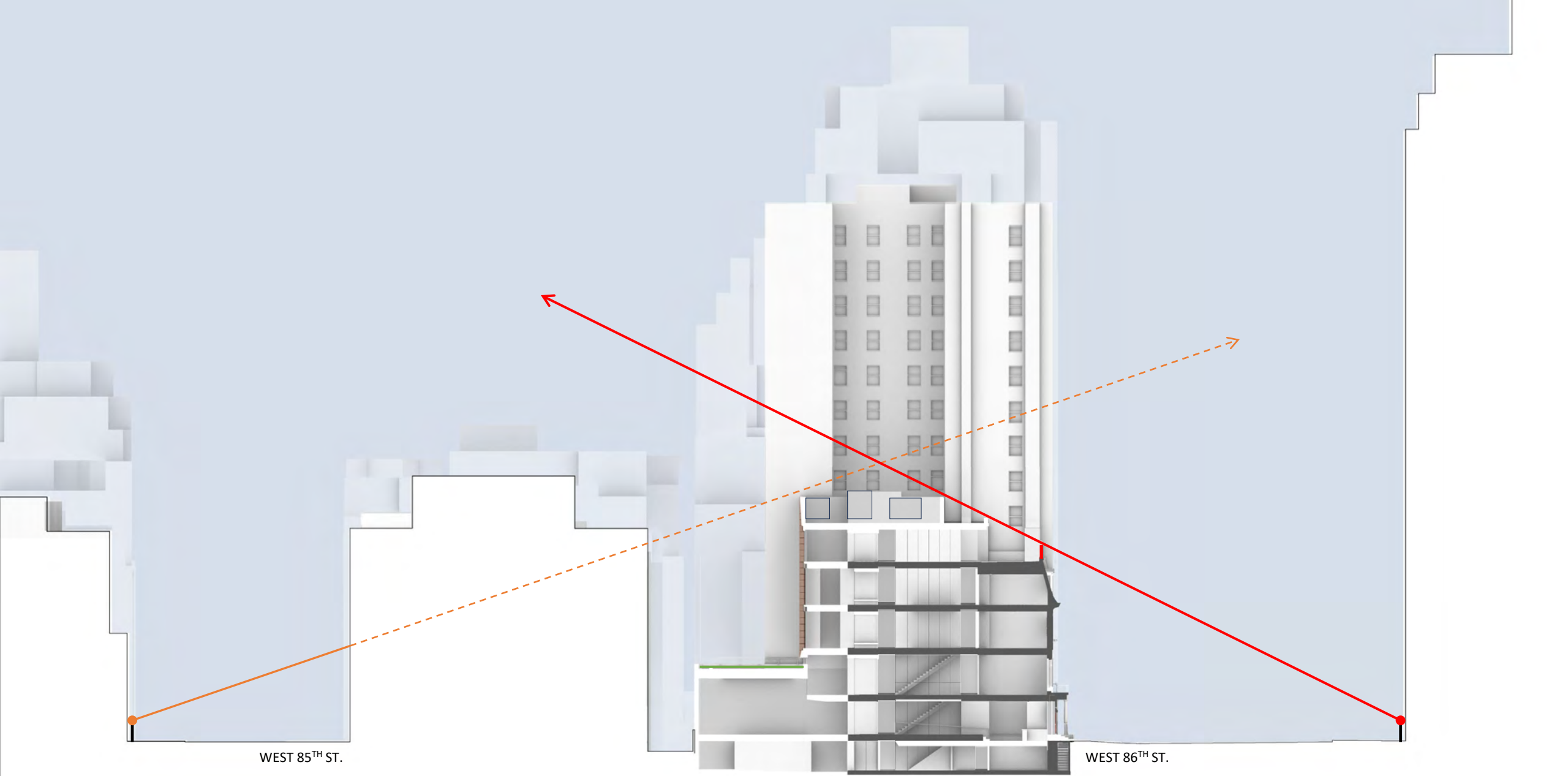

WEST 85<sup>TH</sup> ST.

WEST 86<sup>TH</sup> ST.



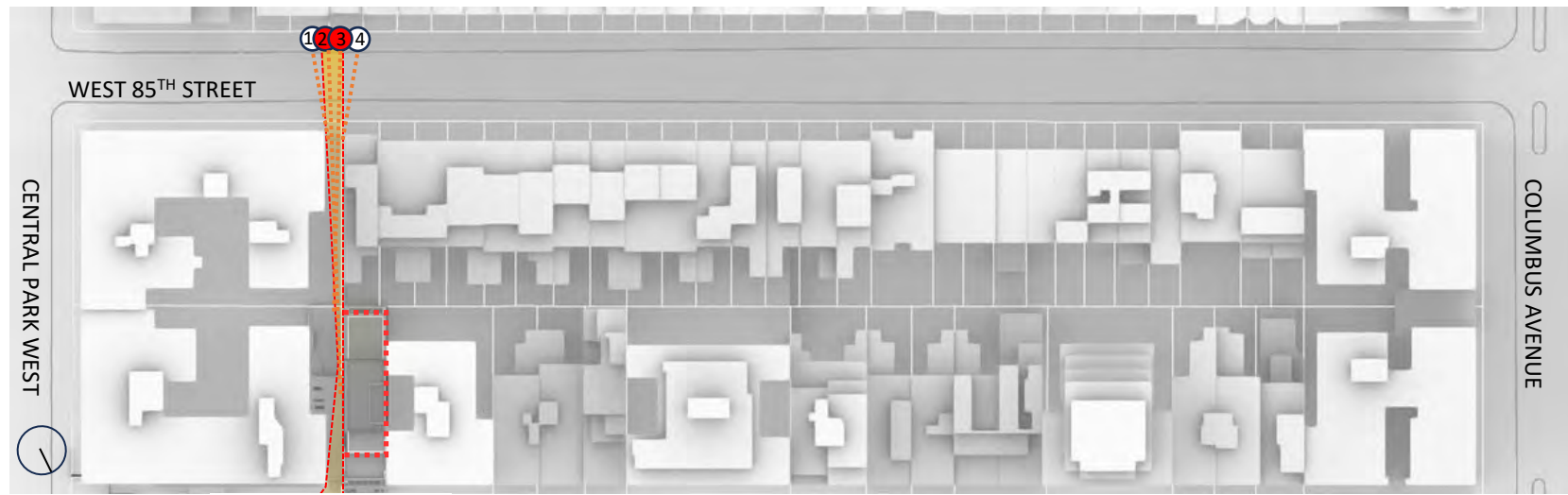
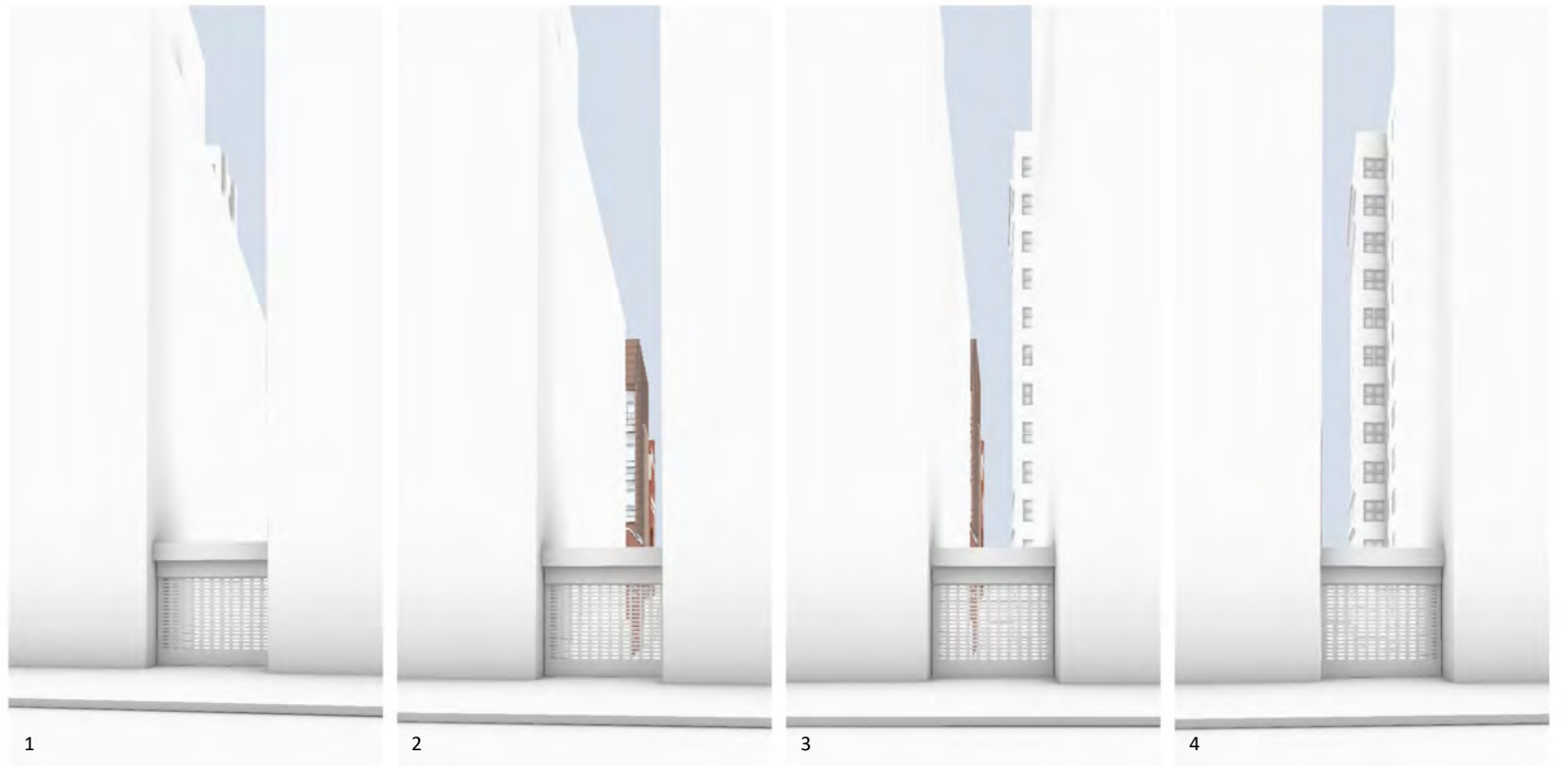





MOCK-UP



PROPOSED





MOCK-UP



PROPOSED



September 17, 2024  
Public Meeting

The current proposal is:

Preservation Department – Item 1, LPC-24-09829

**8 West 86th Street – Upper West Side/Central Park West  
Historic District  
Borough of Manhattan**

To testify virtually, please join Zoom

**Webinar ID:** 860 1689 5962

**Passcode:** 322206

By Phone: 646-558-8656 (NY)

877-853-5257 (Toll free) US

888-475-4499 (Toll free)

**Note:** If you want to testify virtually on an item, join the Zoom webinar at the agenda's "Be Here by" time (about an hour in advance). When the Chair indicates it's time to testify, "raise your hand" via the Zoom app if you want to speak (\*9 on the phone). Those who signed up in advance will be called first.



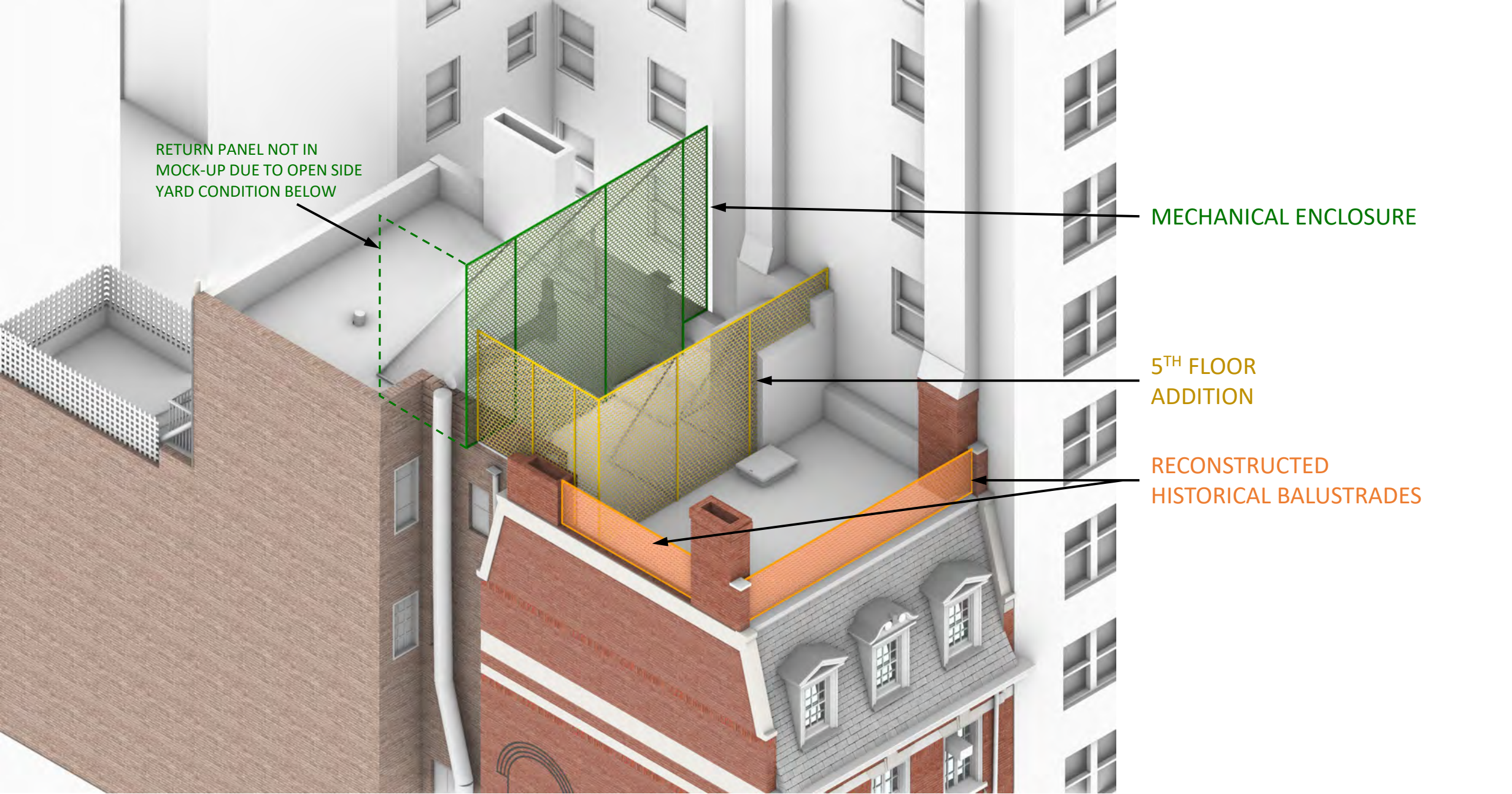





DIAGRAM PREPARED BY LANDMARKS PRESERVATION COMMISSION STAFF





RETURN PANEL NOT IN  
MOCK-UP DUE TO OPEN SIDE  
YARD CONDITION BELOW

MECHANICAL ENCLOSURE

5<sup>TH</sup> FLOOR  
ADDITION

RECONSTRUCTED  
HISTORICAL BALUSTRADES





ENLARGED DIAGONAL VIEW

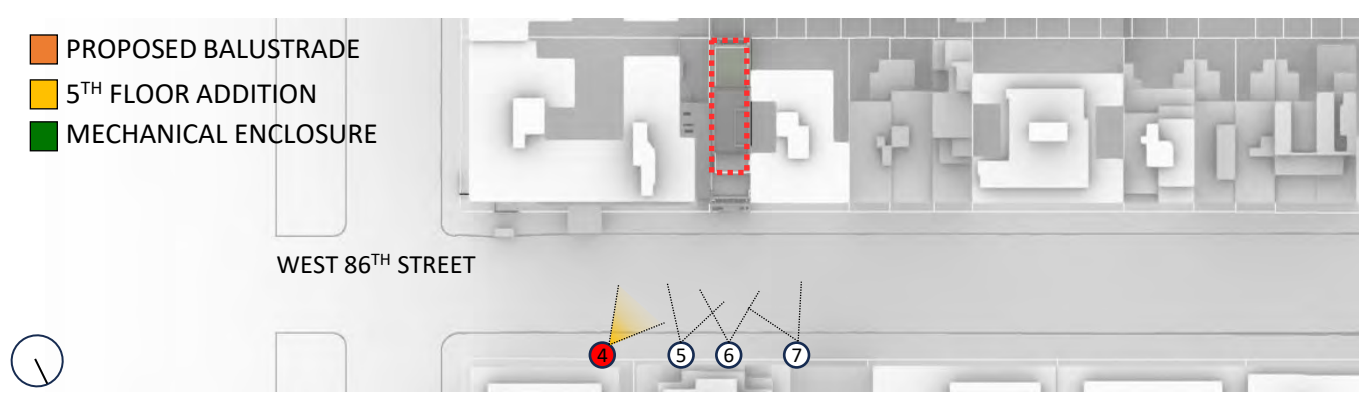





ENLARGED SOUTHWEST VIEW

- PROPOSED BALUSTRADE
- 5<sup>TH</sup> FLOOR ADDITION
- MECHANICAL ENCLOSURE



WEST 86<sup>TH</sup> STREET

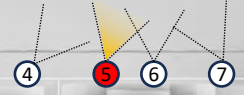





ENLARGED VIEW DIRECTLY ACROSS WEST 86<sup>TH</sup> STREET

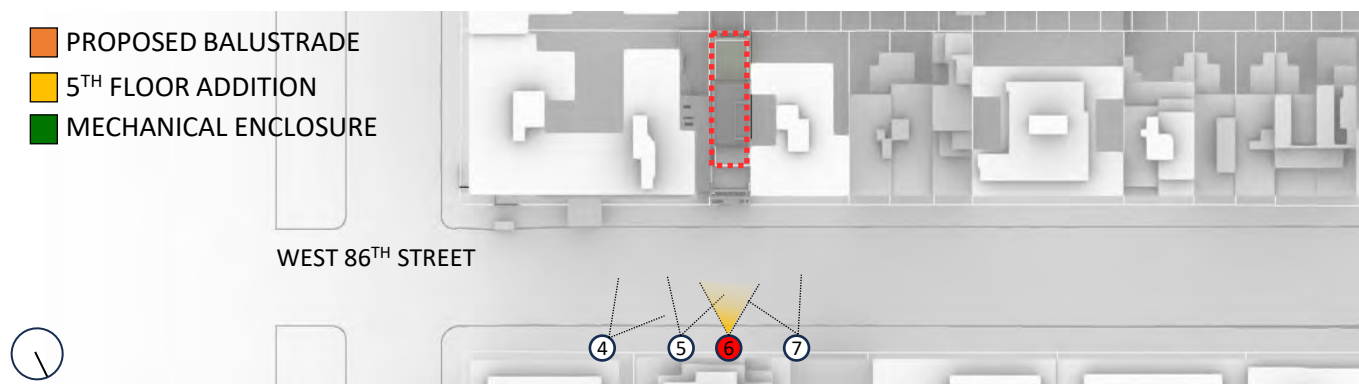





ENLARGED SOUTHEAST VIEW

- PROPOSED BALUSTRADE
- 5<sup>TH</sup> FLOOR ADDITION
- MECHANICAL ENCLOSURE



WEST 86<sup>TH</sup> STREET

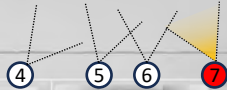









Rear View of 8 West 86<sup>th</sup> Street from Courtyard

Rear View of 8 West 86<sup>th</sup> Street from Service Alley





Rear Yard View of 19 and 21 West 85<sup>th</sup> Street from 3<sup>rd</sup> Floor Deck



Rear Yard View of West 85<sup>th</sup> Street Looking Southwest





View Looking South of Adjacent Service Alley



View Looking South at Rear Yard of 8 West 86th Street and Service Alley



The current proposal is:

Preservation Department – Item 1, LPC-24-09829

**8 West 86th Street – Upper West Side/Central Park West  
Historic District  
Borough of Manhattan**

To testify virtually, please join Zoom

**Webinar ID:** 860 1689 5962

**Passcode:** 322206

By Phone: 646-558-8656 (NY)

877-853-5257 (Toll free) US

888-475-4499 (Toll free)

**Note:** If you want to testify virtually on an item, join the Zoom webinar at the agenda's "Be Here by" time (about an hour in advance). When the Chair indicates it's time to testify, "raise your hand" via the Zoom app if you want to speak (\*9 on the phone). Those who signed up in advance will be called first.