

October 22, 2024  
Public Hearing

The current proposal is:

Preservation Department – Item 2, LPC-25-02798

# 116 Pierrepont Street – Brooklyn Heights Historic District Borough of Brooklyn

To testify virtually, please join Zoom

**Webinar ID:** 845 8560 8546

**Passcode:** 804927

By Phone: 646-558-8656 (NY)

877-853-5257 (Toll free) US

888-475-4499 (Toll free)

**Note:** If you want to testify virtually on an item, join the Zoom webinar at the agenda's "Be Here by" time (about an hour in advance). When the Chair indicates it's time to testify, "raise your hand" via the Zoom app if you want to speak (\*9 on the phone). Those who signed up in advance will be called first.





PROPOSED RENOVATION AT  
**116 PIERREPONT ST**  
**BROOKLYN, NY 11201**







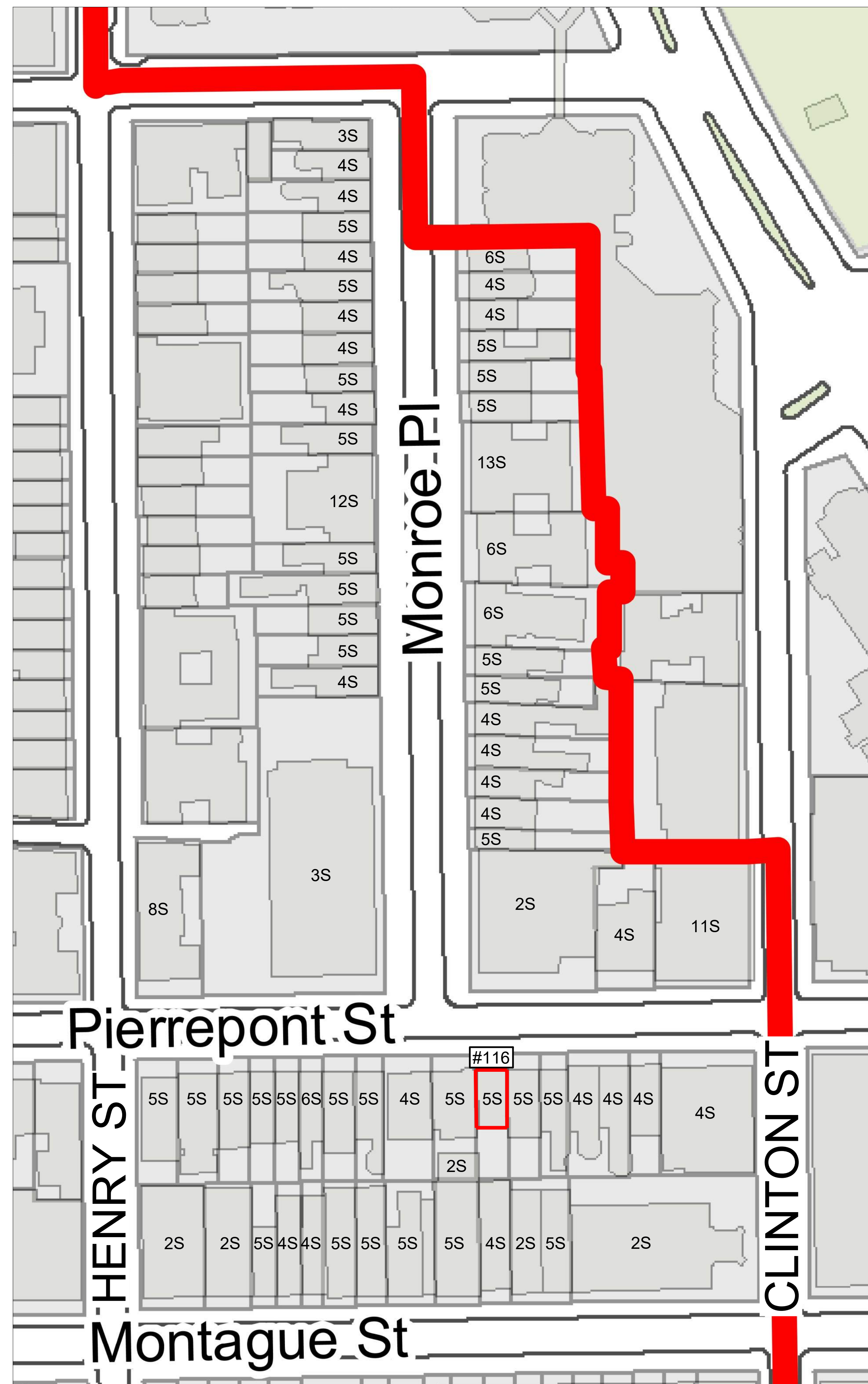
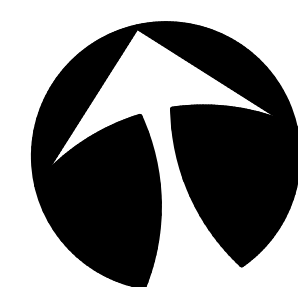





1940s HISTORIC TAX PHOTO

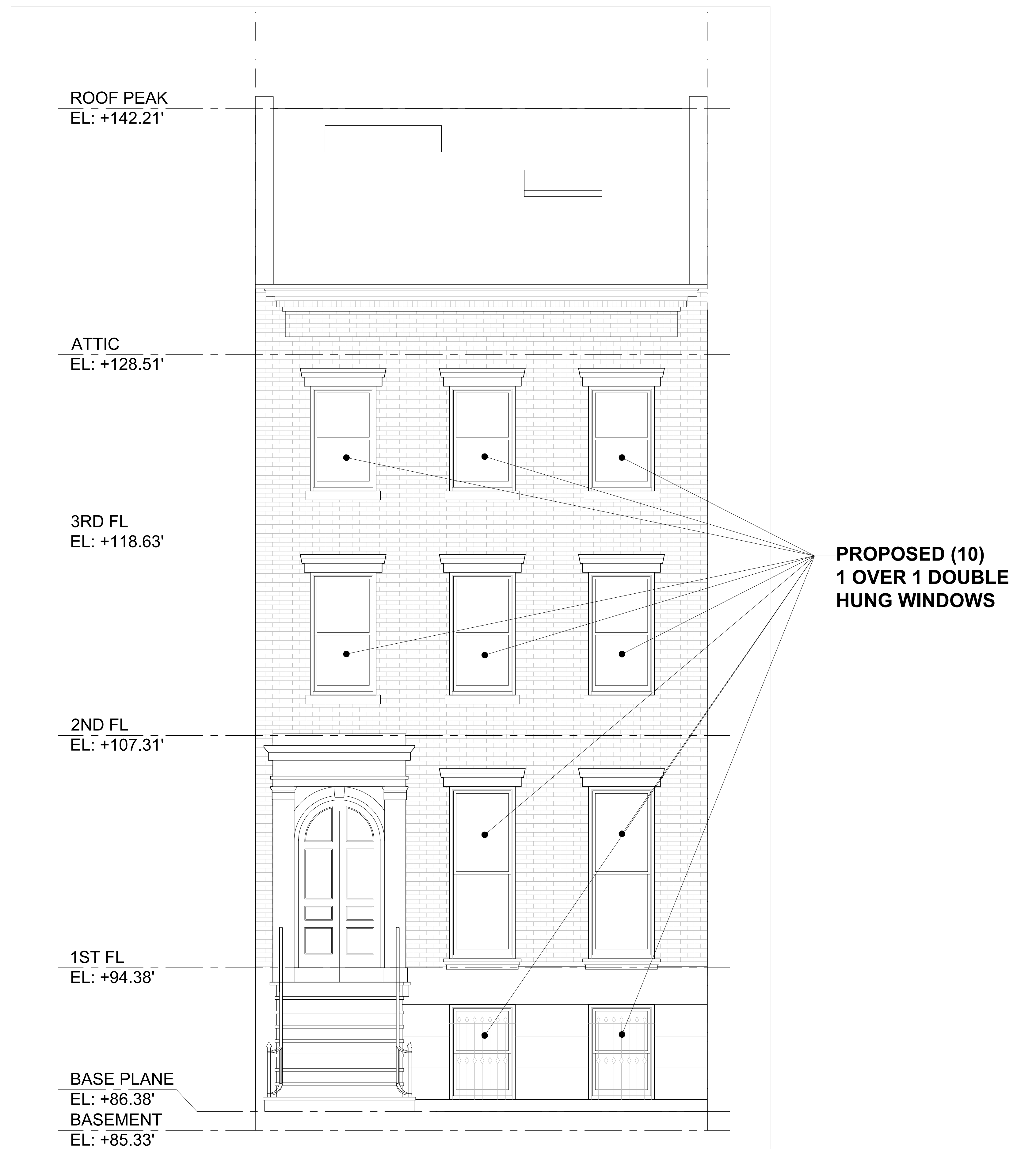



PROPOSED ELEVATION

HISTORIC & PROPOSED PRIMARY FACADE | 116 PIERREPONT ST  
 BROOKLYN NY 11201

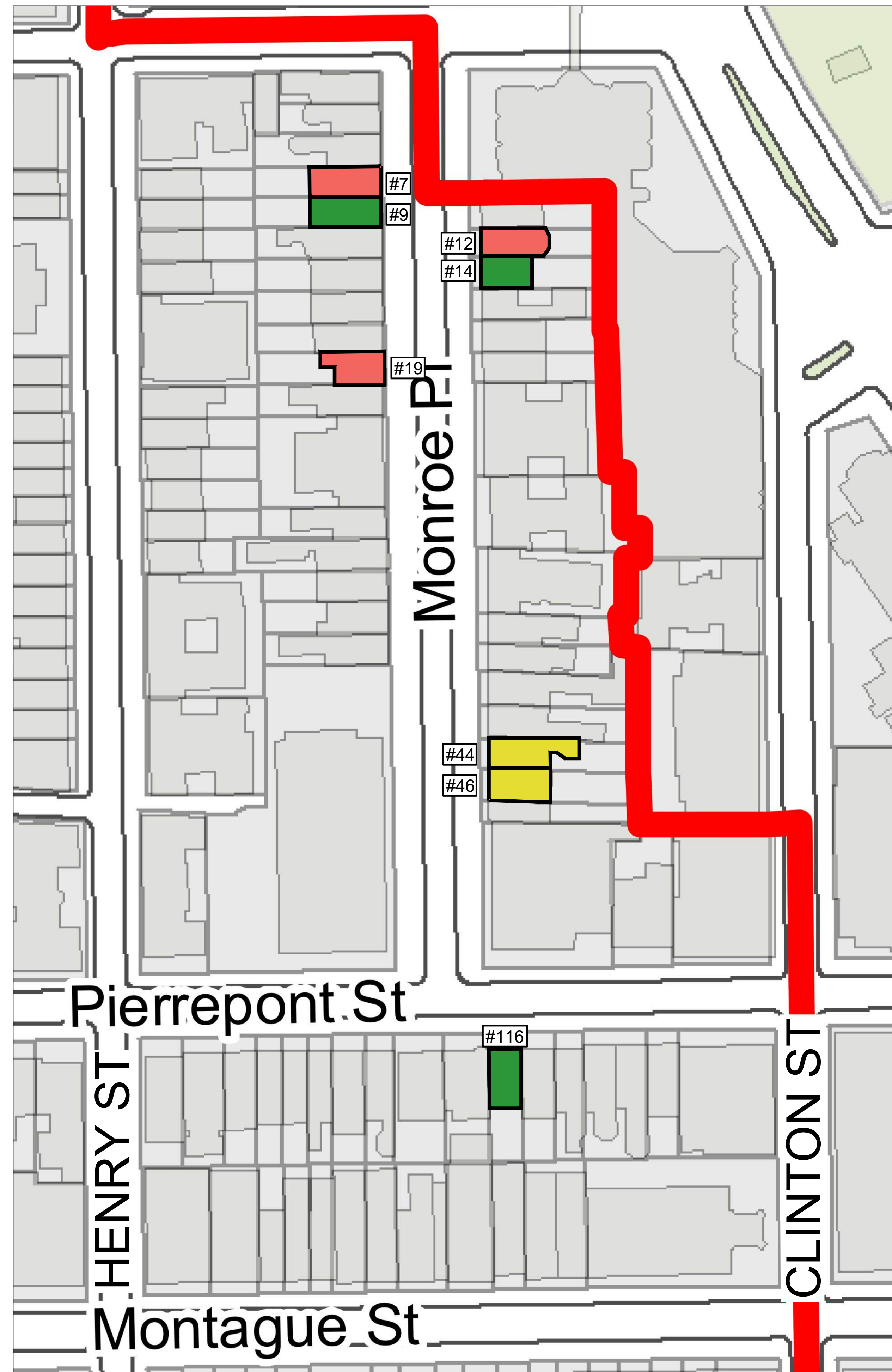
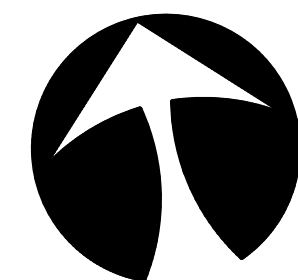



-  1 OVER 1 WINDOWS (3)
-  2 OVER 2 WINDOWS (2)
-  6 OVER 6 WINDOWS (3)





**9 MONROE PL - GREEK REVIVAL 1845**  
2006 permit to replace (6) 1 over 1 with (6) 1 over 1



**14 MONROE PL - NO STYLE LISTED 1847**  
No window permits on file



**44 MONROE PL - GREEK REVIVAL 1837**  
2015 permit to replace (8) 12 over 1 with (8) 2 over 2



**46 MONROE PL - GREEK REVIVAL 1835**  
2006 permit to replace (10) 1 over 1 with (10) 2 over 2



**116 PIERREPONT ST - GREEK REVIVAL 1844**

**EXISTING GREEK REVIVAL STYLE BUILDINGS | 116 PIERREPONT ST  
WITH 1/1 & 2/2 CONFIGURATION | BROOKLYN NY 11201**





116 PIERREPONT ST

EAST OF SITE

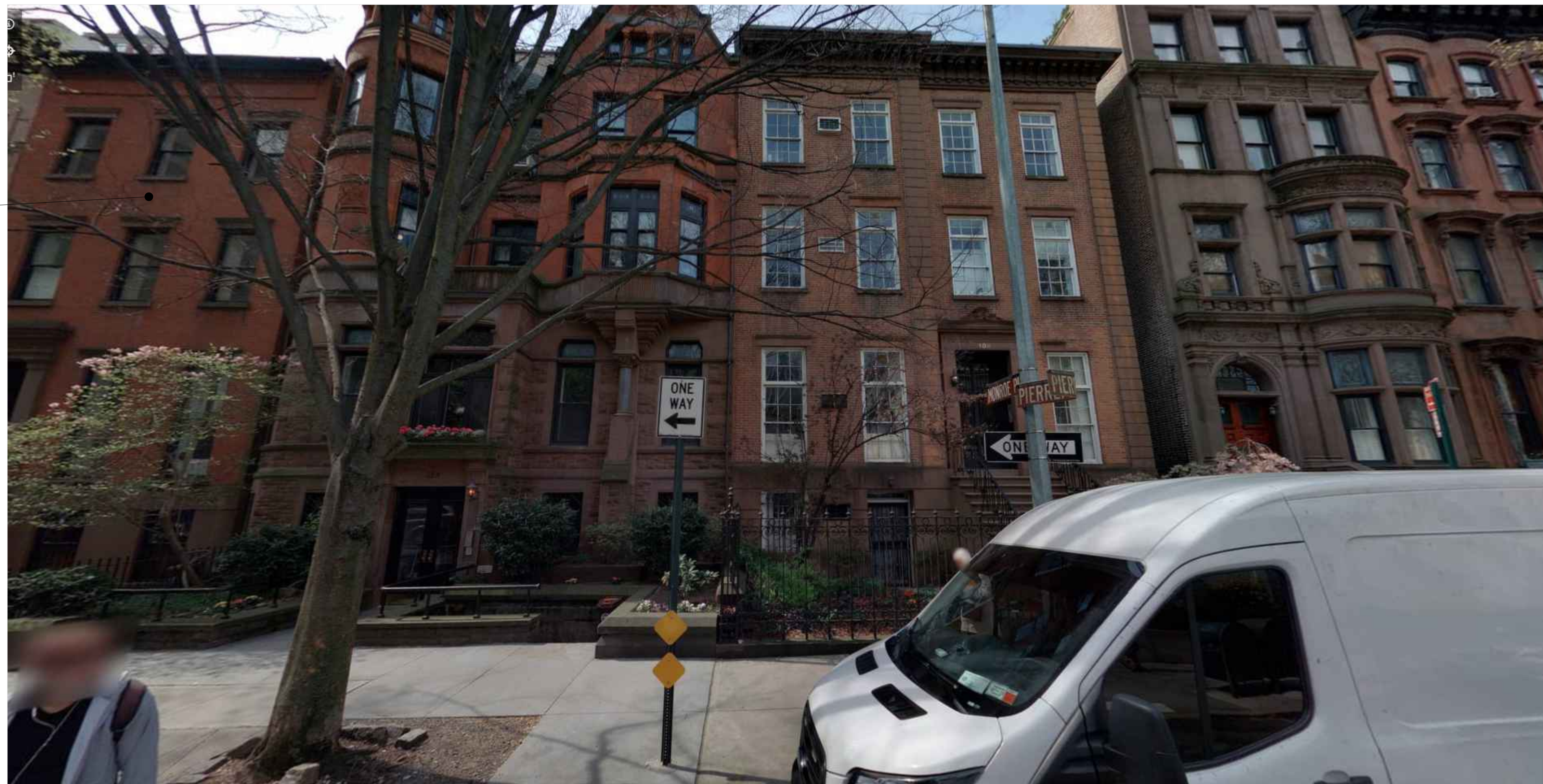

116 PIERREPONT ST

WEST OF SITE

NEIGHBORING BUILDINGS | 116 PIERREPONT ST  
CONTEXT | BROOKLYN NY 11201



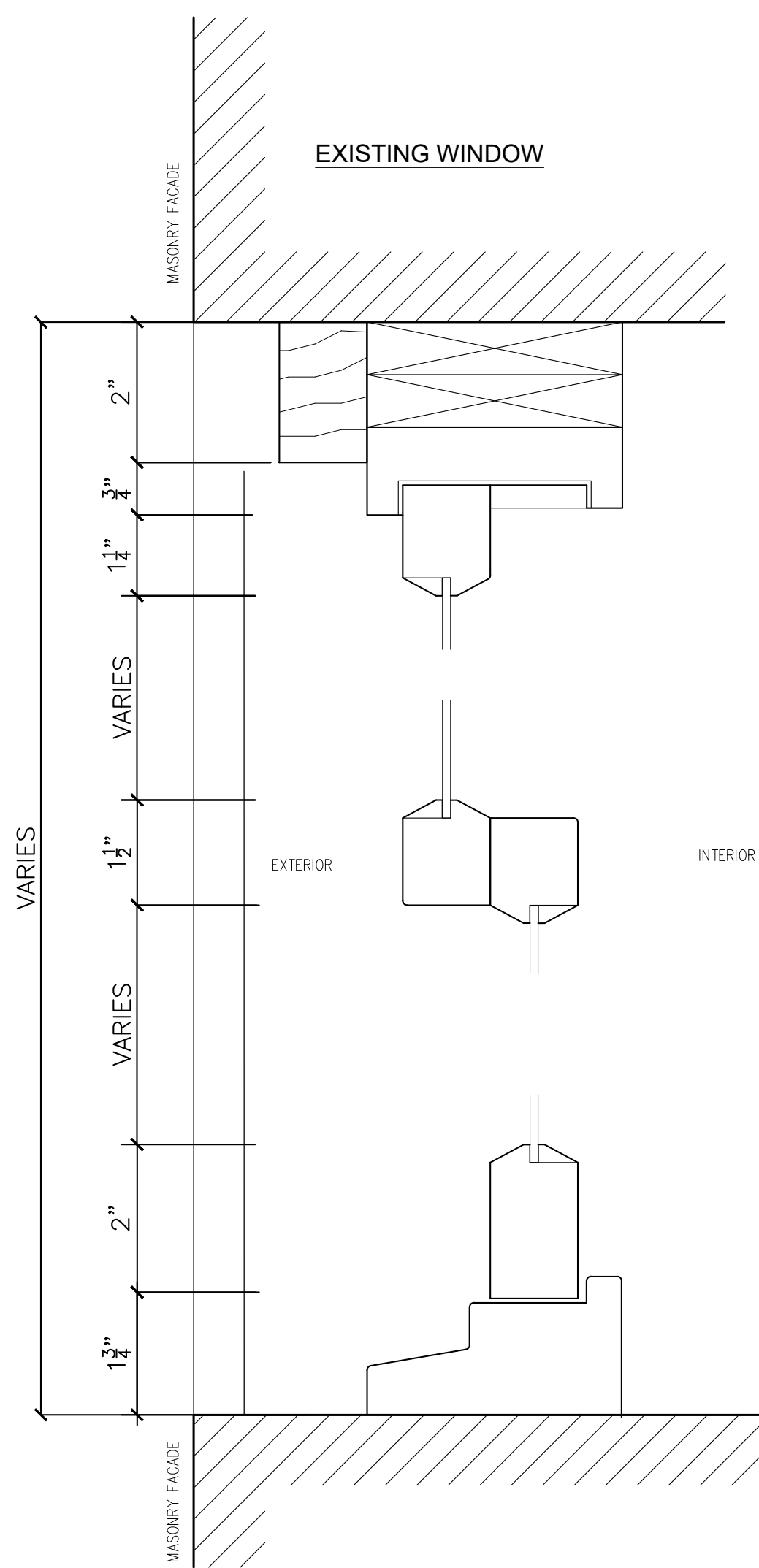

**EXISTING WINDOW  
SILL AND HEAD DETAILS**

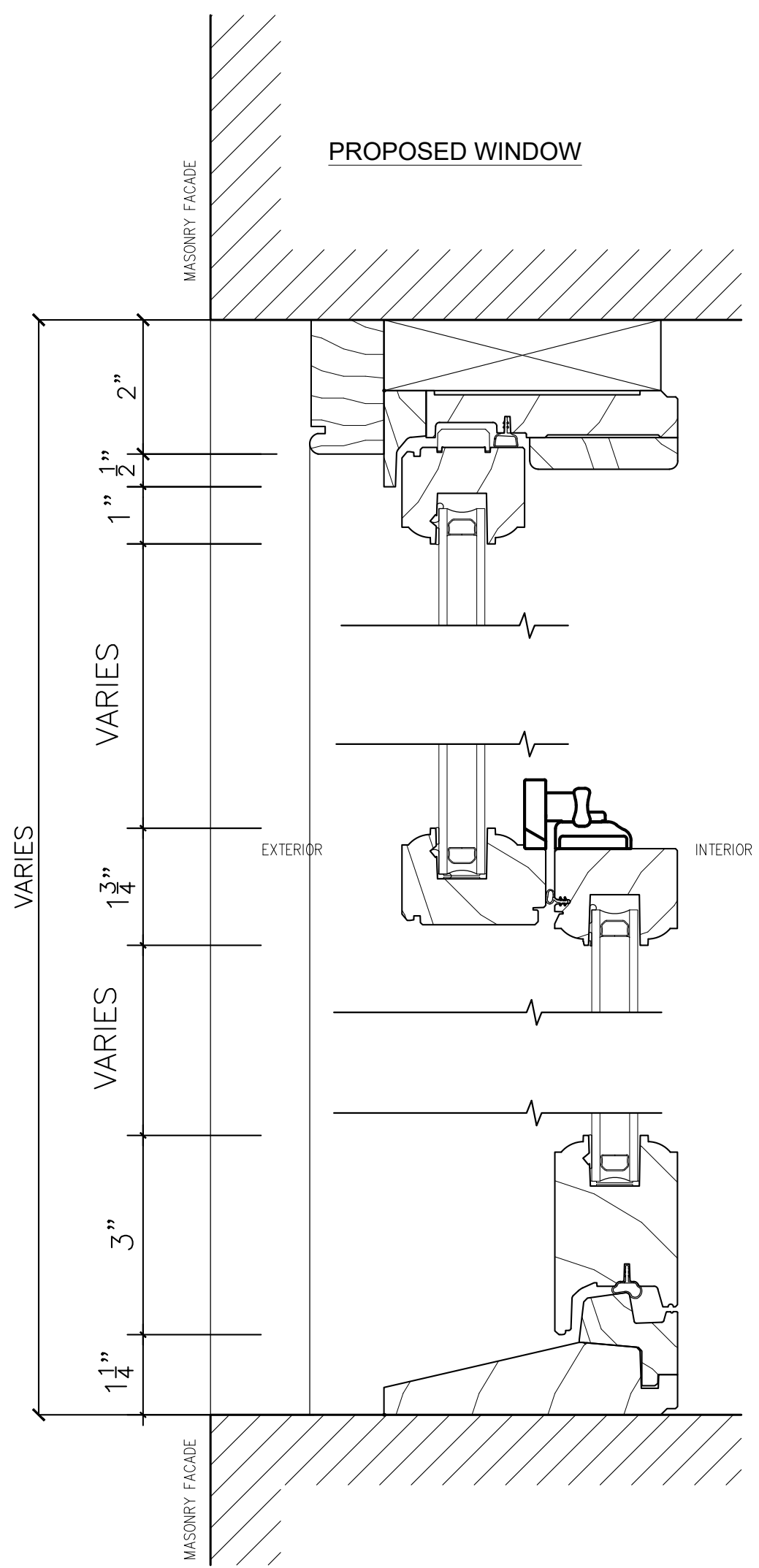

**PROPOSED WINDOW  
SILL AND HEAD DETAILS**

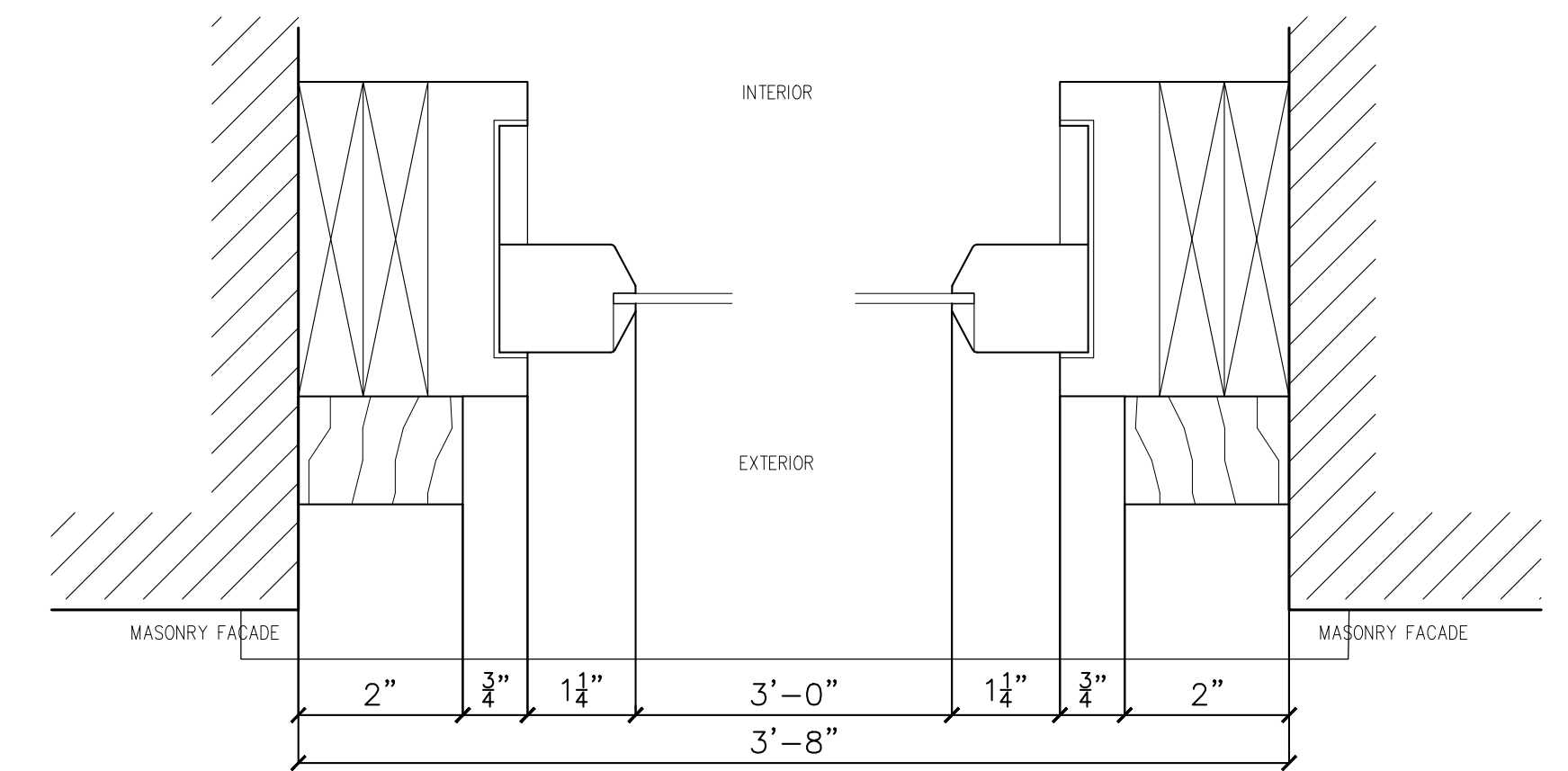

**EXISTING WINDOW  
JAMB DETAILS**

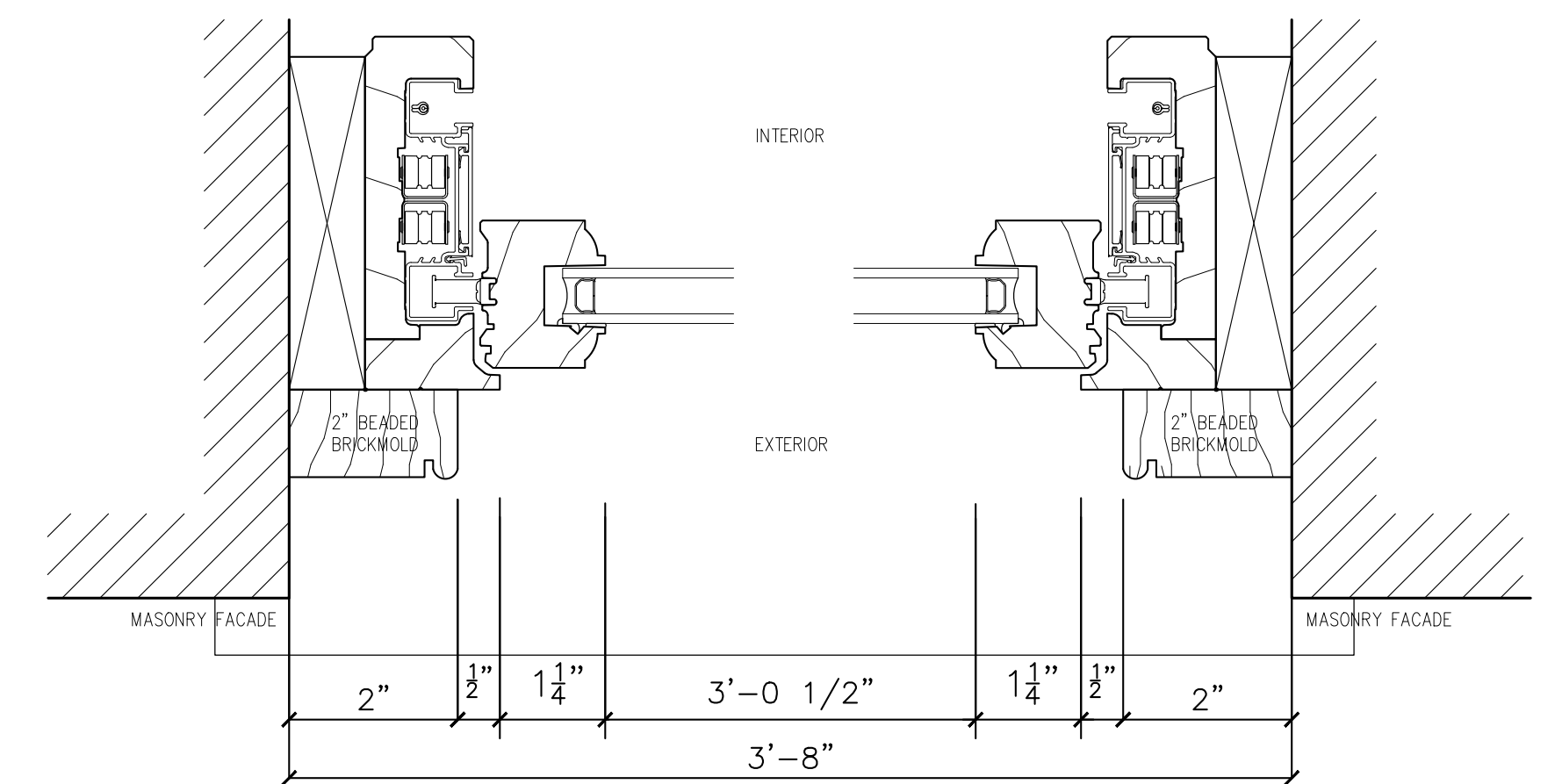

**EXISTING WINDOW  
JAMB DETAILS**





1940s HISTORIC TAX PHOTO



EXISTING CONDITION



PROPOSED ELEVATION

HISTORIC, EXISTING & PROPOSED | 116 PIERREPONT ST  
 PRIMARY FACADE | BROOKLYN NY 11201



October 22, 2024  
Public Hearing

The current proposal is:

Preservation Department – Item 2, LPC-25-02798

# 116 Pierrepont Street – Brooklyn Heights Historic District Borough of Brooklyn

To testify virtually, please join Zoom

**Webinar ID:** 845 8560 8546

**Passcode:** 804927

By Phone: 646-558-8656 (NY)

877-853-5257 (Toll free) US

888-475-4499 (Toll free)

**Note:** If you want to testify virtually on an item, join the Zoom webinar at the agenda's "Be Here by" time (about an hour in advance). When the Chair indicates it's time to testify, "raise your hand" via the Zoom app if you want to speak (\*9 on the phone). Those who signed up in advance will be called first.