

October 29, 2024
Public Hearing

The current proposal is:

Preservation Department – Item 12, LPC-25-03298

1185 Park Avenue – Expanded Carnegie Hill Historic District Borough of Manhattan

To testify virtually, please join Zoom

Webinar ID: 820 4014 2259

Passcode: 476351

By Phone: 646-558-8656 (NY)

877-853-5257 (Toll free) US

888-475-4499 (Toll free)

Note: If you want to testify virtually on an item, join the Zoom webinar at the agenda's "Be Here by" time (about an hour in advance). When the Chair indicates it's time to testify, "raise your hand" via the Zoom app if you want to speak (*9 on the phone). Those who signed up in advance will be called first.

1185 Park Avenue

Lightwell Restoration

LPC Commission Hearing
October 29, 2024

1185 Park Ave.

1- History of Court Yard

2- Existing Lightwell

3- Proposed Lightwell

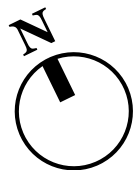
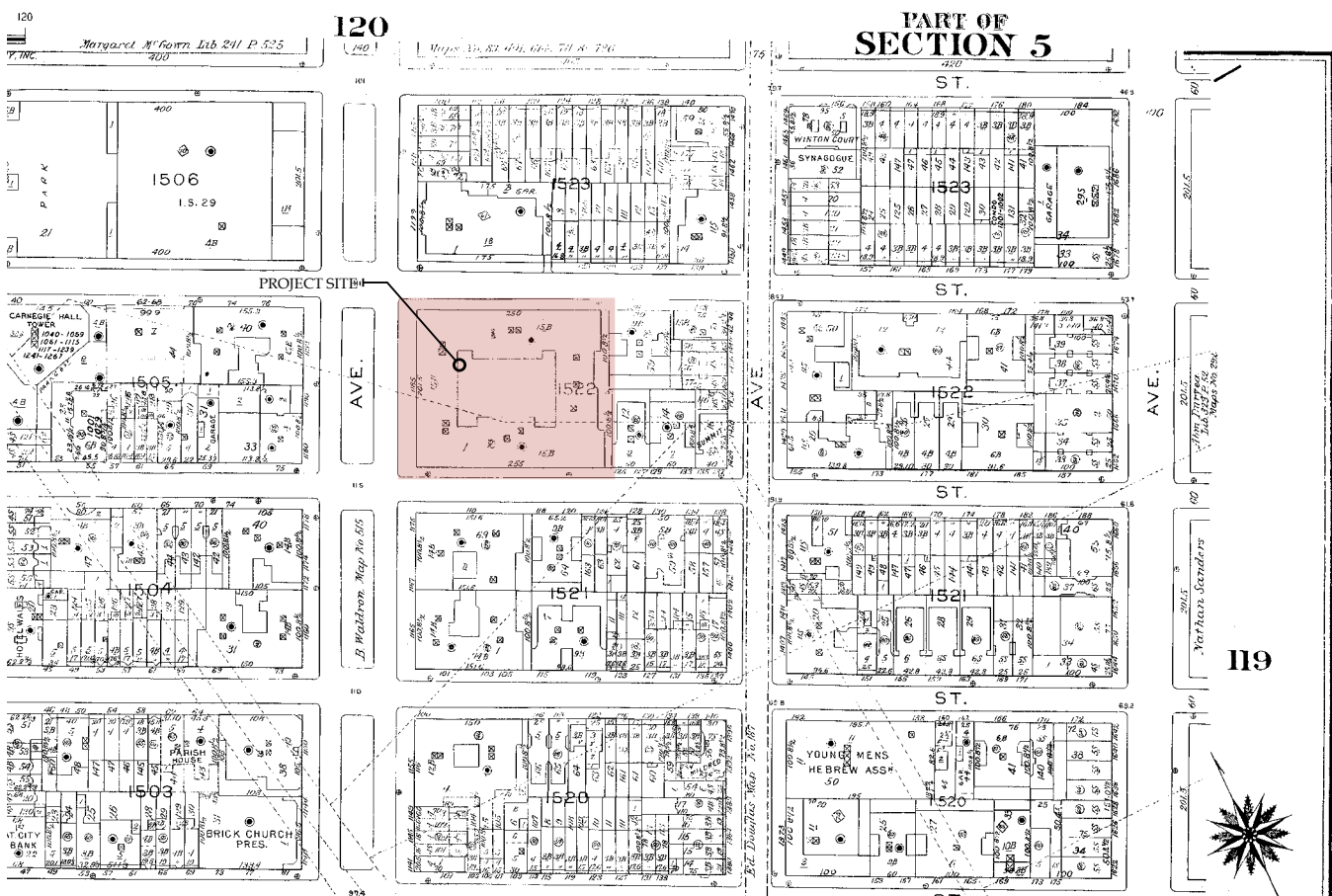



1940 Tax Photo



1993 Designation Photo



1929



1959



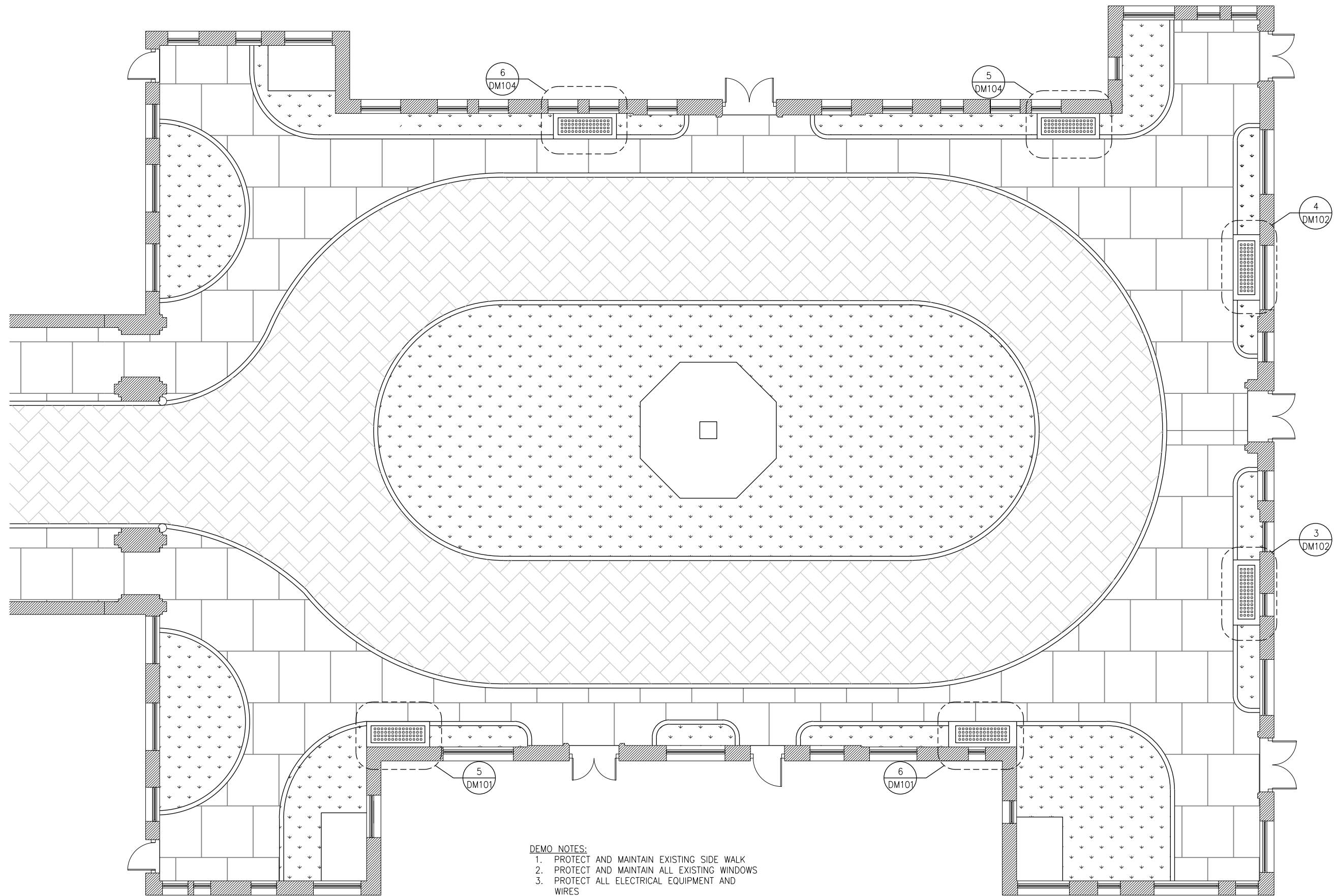

- DEMO NOTES:
1. PROTECT AND MAINTAIN EXISTING SIDE WALK
 2. PROTECT AND MAINTAIN ALL EXISTING WINDOWS
 3. PROTECT ALL ELECTRICAL EQUIPMENT AND WIRES



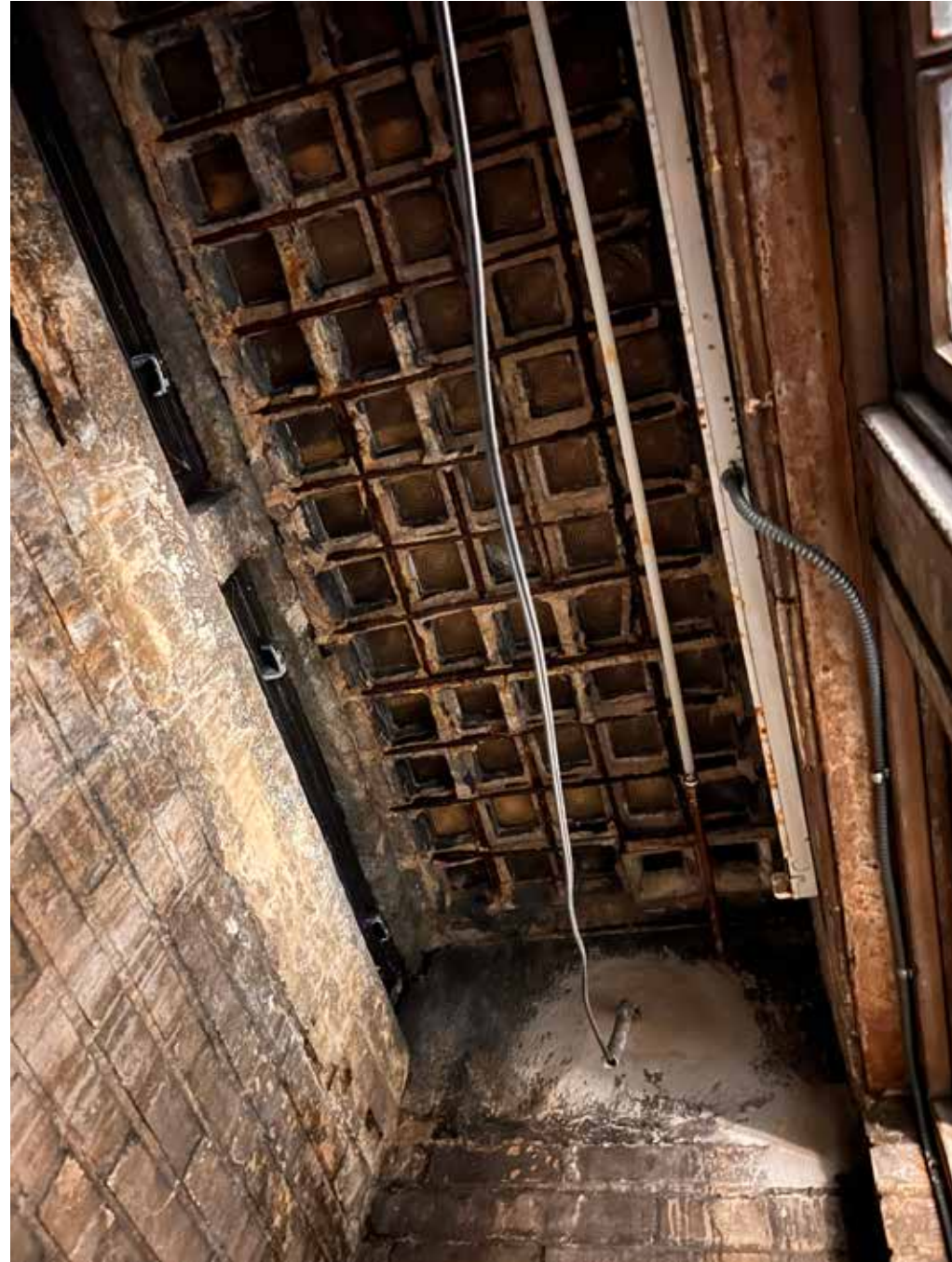

Existing Lightwells Interior

Proposed Design



Existing Light Well



Proposed Light Well



Proposed Diagram

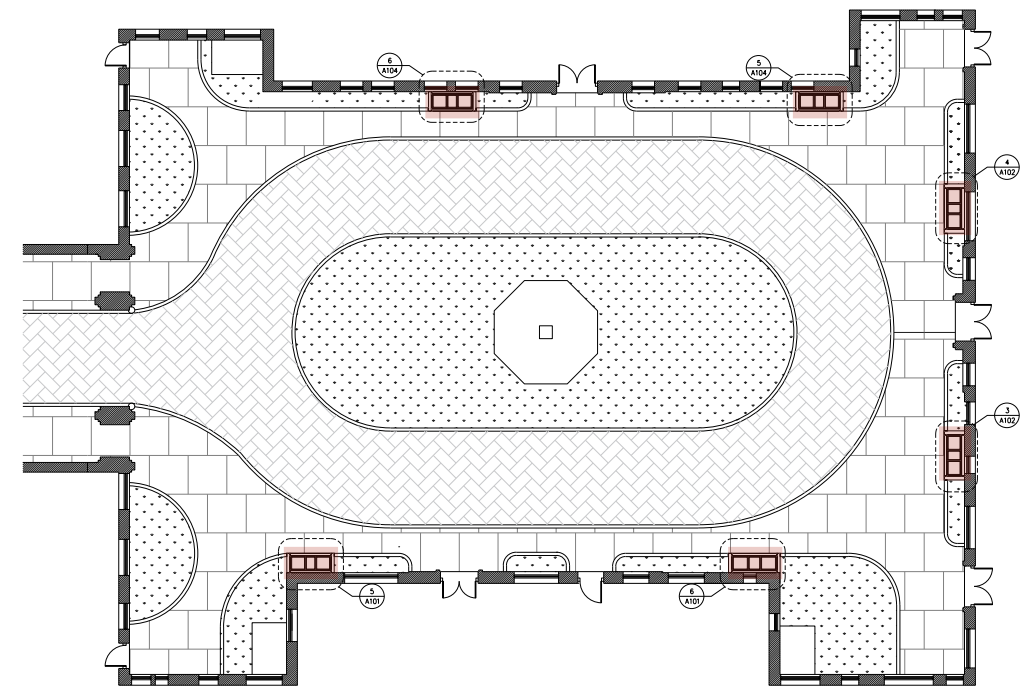

Key Plan

Proposed Render

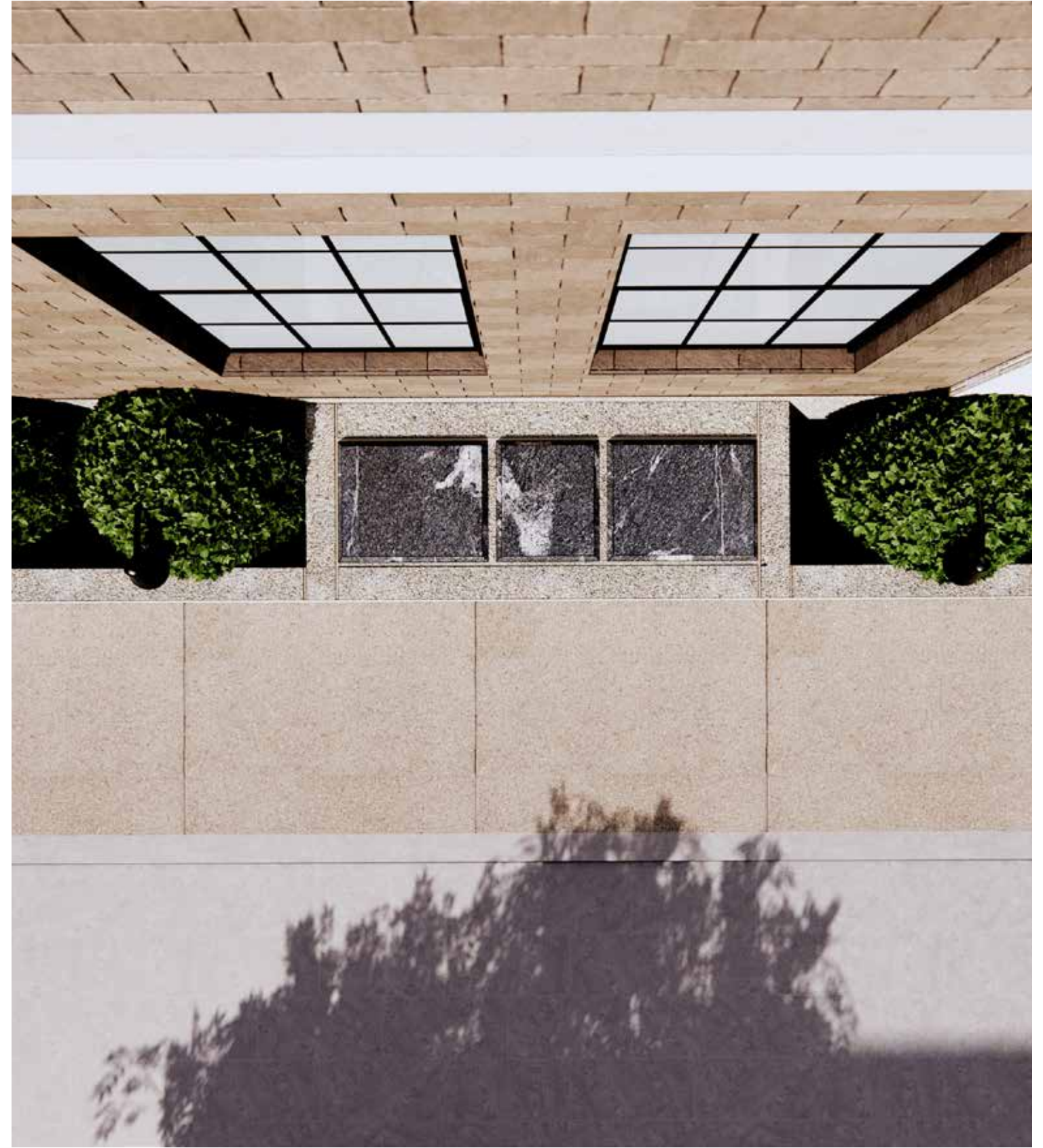

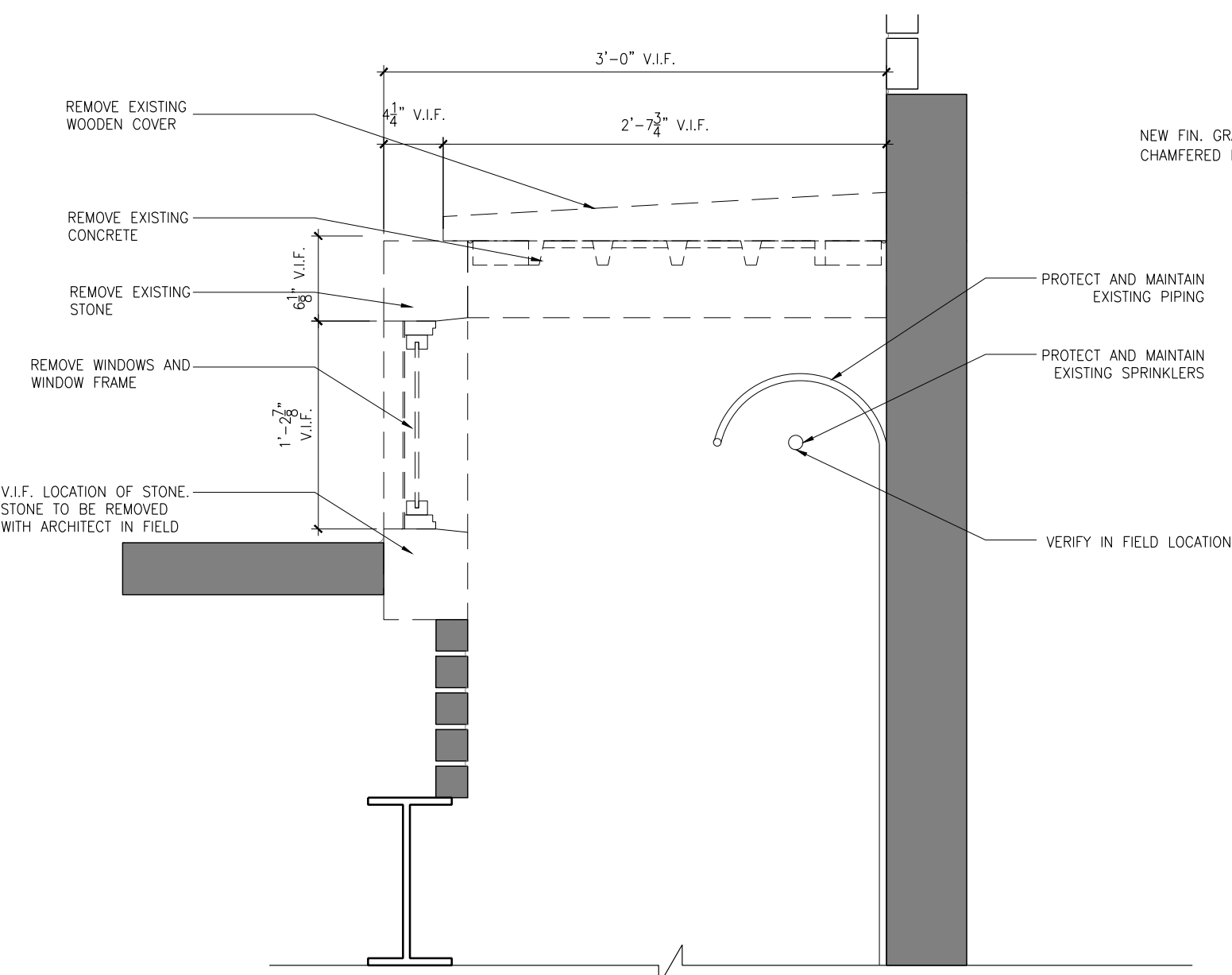

Typ. Demo Section

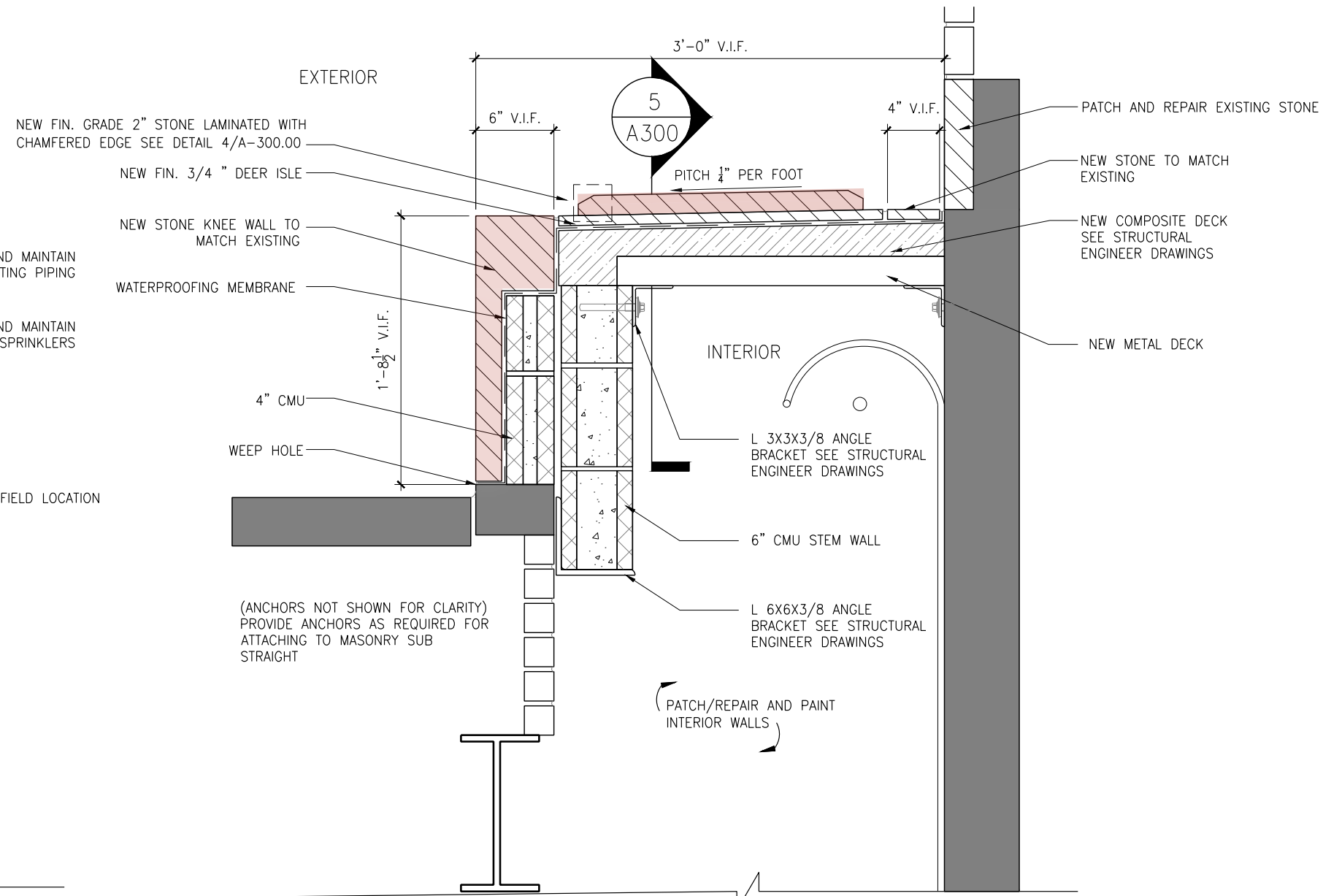

Typ. Proposed Section

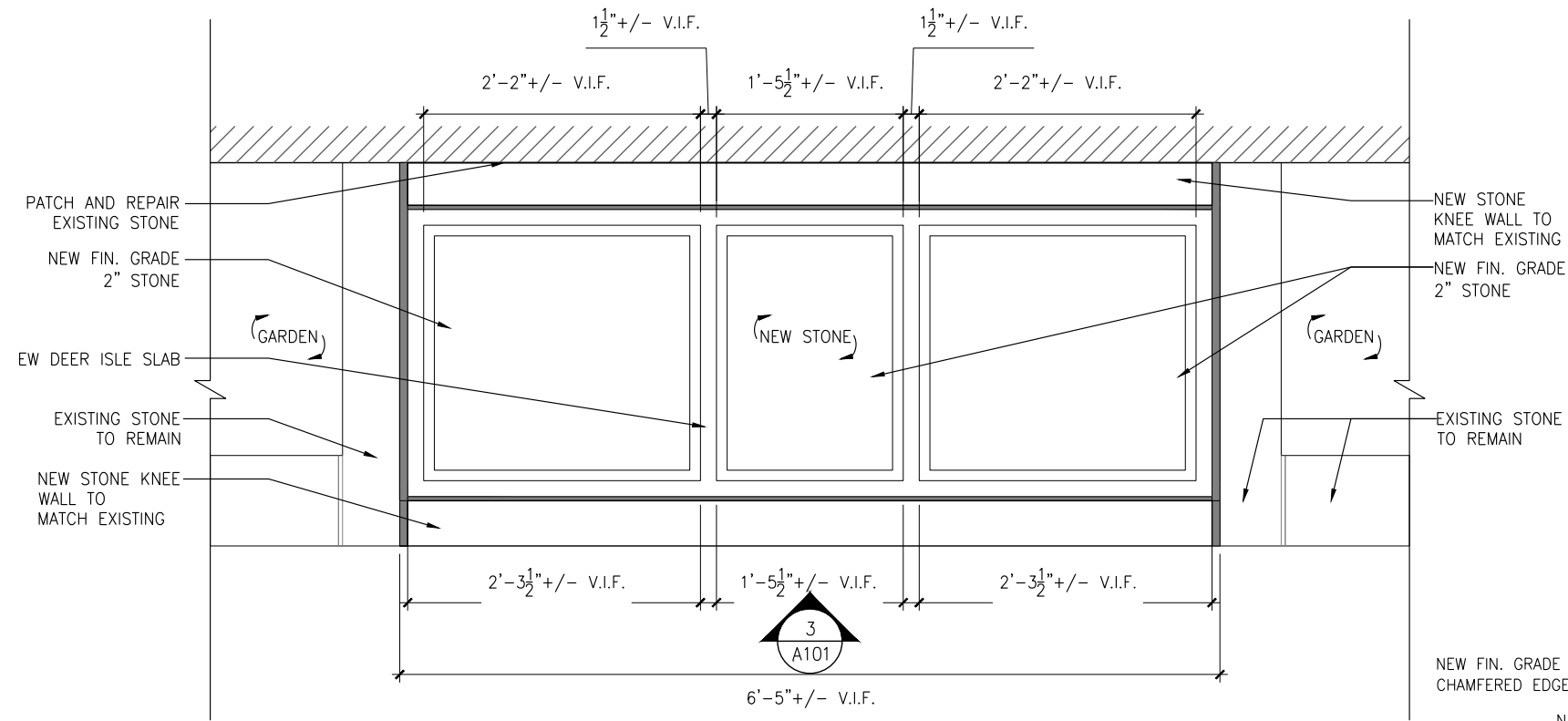

Typ. Proposed Elevation

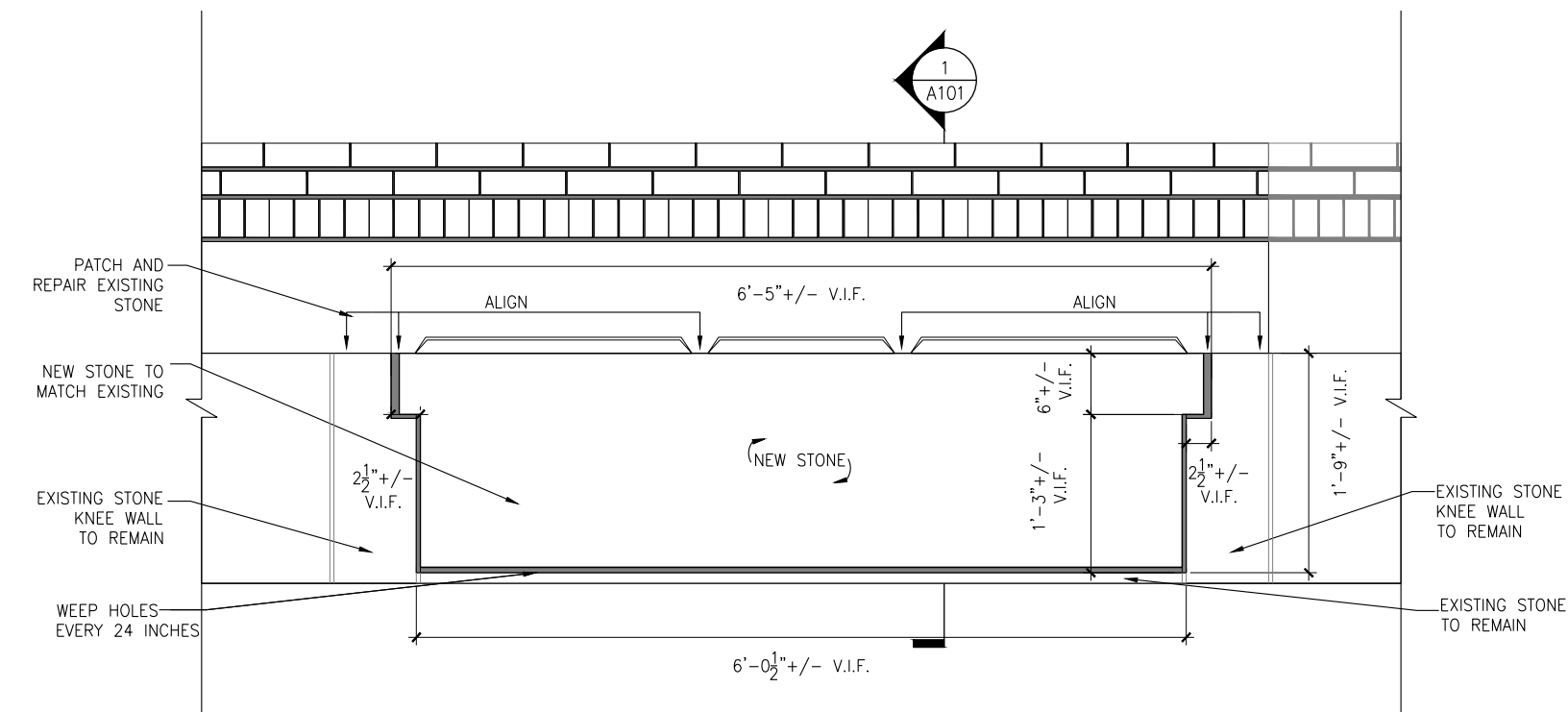

Typ. Proposed Section

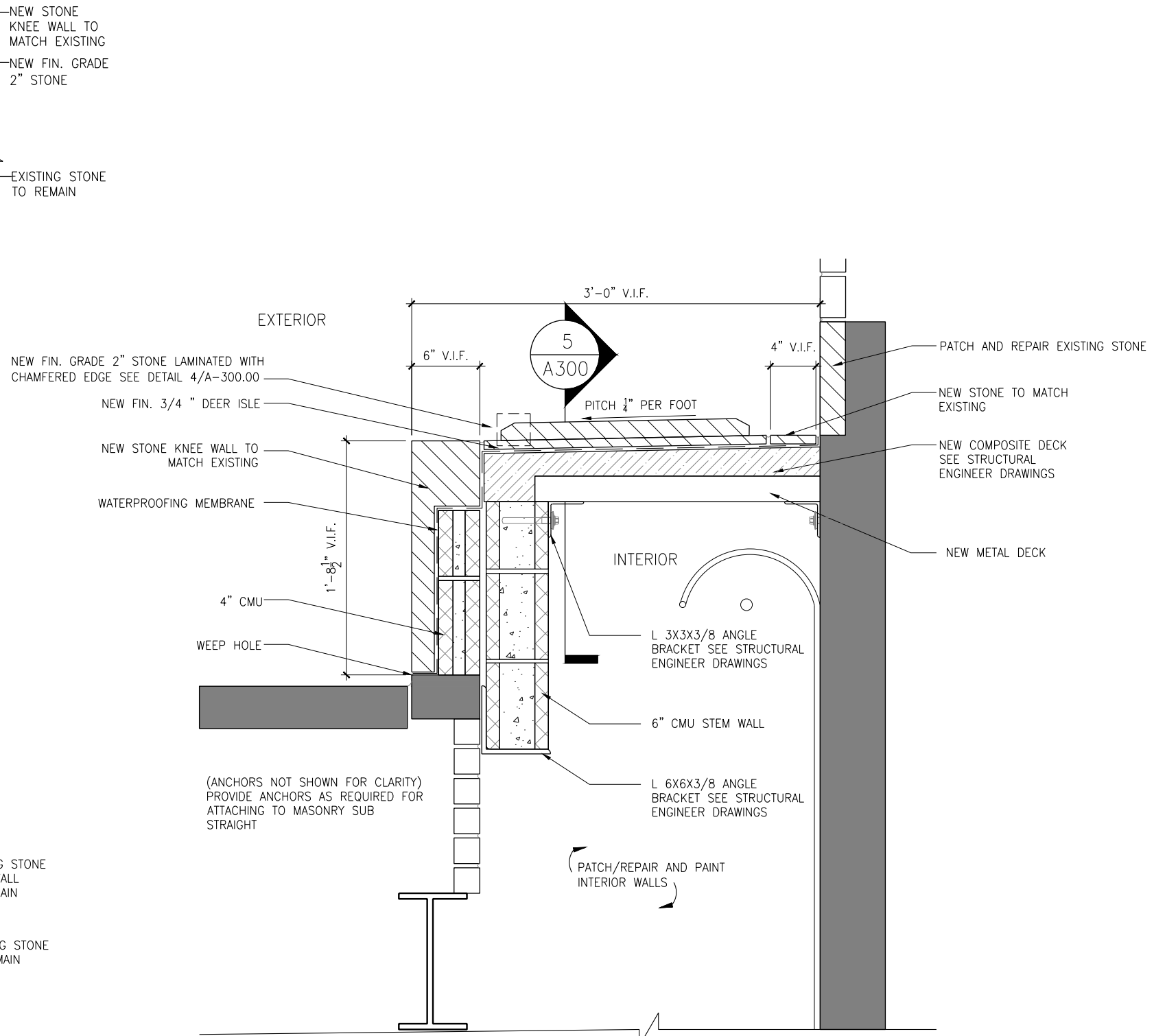

Typ. Proposed Section



October 29, 2024
Public Hearing

The current proposal is:

Preservation Department – Item 12, LPC-25-03298

1185 Park Avenue – Expanded Carnegie Hill Historic District Borough of Manhattan

To testify virtually, please join Zoom

Webinar ID: 820 4014 2259

Passcode: 476351

By Phone: 646-558-8656 (NY)

877-853-5257 (Toll free) US

888-475-4499 (Toll free)

Note: If you want to testify virtually on an item, join the Zoom webinar at the agenda's "Be Here by" time (about an hour in advance). When the Chair indicates it's time to testify, "raise your hand" via the Zoom app if you want to speak (*9 on the phone). Those who signed up in advance will be called first.