

October 29, 2024
Public Hearing

The current proposal is:

Preservation Department – Item 8, LPC-25-02666

70 Perry Street – Greenwich Village Historic District Borough of Manhattan

To testify virtually, please join Zoom

Webinar ID: 820 4014 2259

Passcode: 476351

By Phone: 646-558-8656 (NY)

877-853-5257 (Toll free) US

888-475-4499 (Toll free)

Note: If you want to testify virtually on an item, join the Zoom webinar at the agenda's "Be Here by" time (about an hour in advance). When the Chair indicates it's time to testify, "raise your hand" via the Zoom app if you want to speak (*9 on the phone). Those who signed up in advance will be called first.

70 PERRY STREET

Greenwich Village Historic District
Borough of Manhattan
LPC-25-02666

Building Information

Constructed: 1867
4 Stories + Basement + Cellar
Residential



Scope

Addition of Glass Lites in the
First Floor Entrance Door.



GREENWICH VILLAGE HISTORIC DISTRICT

PROJECT LOCATION

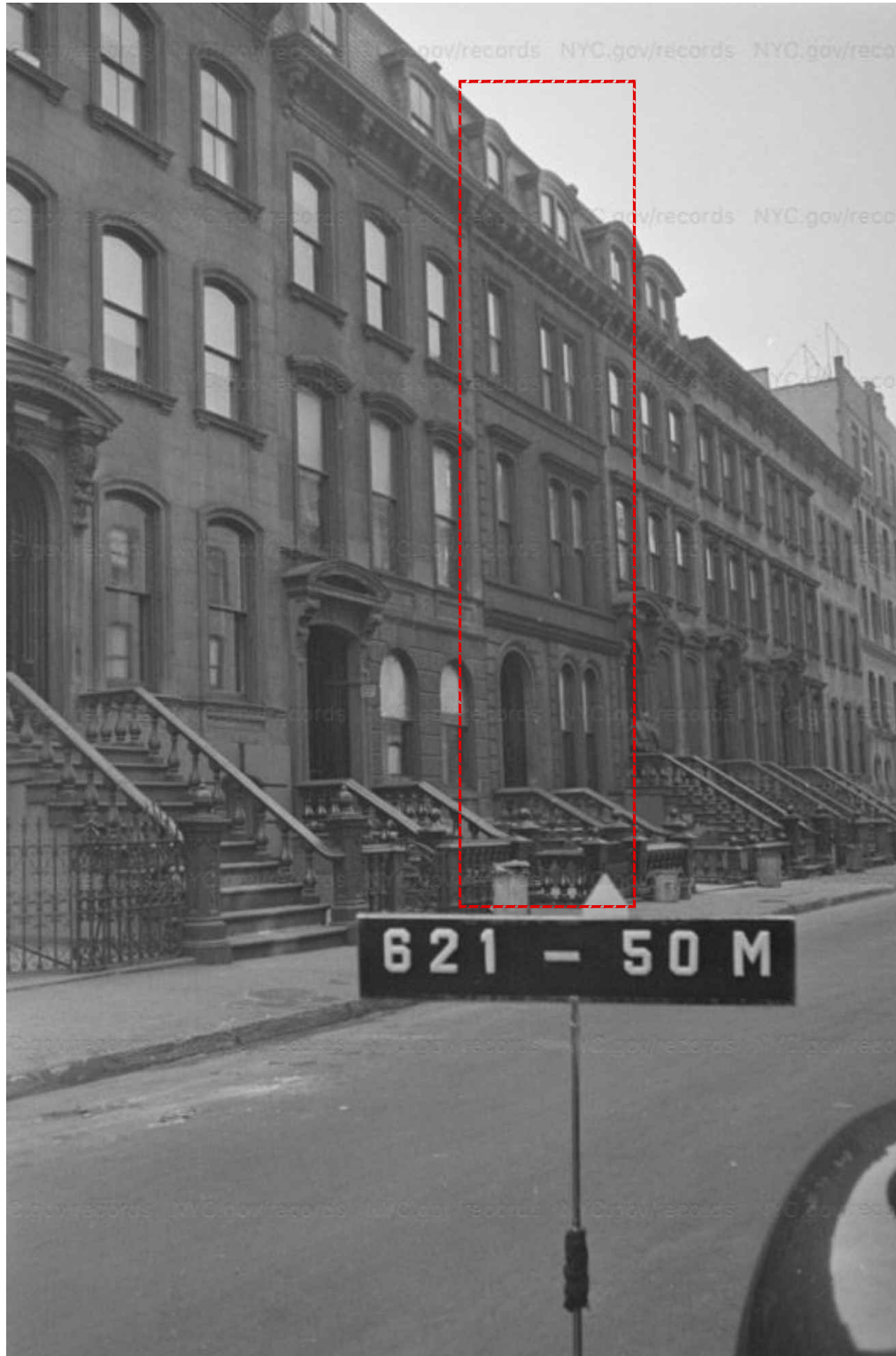

1941 TAX PHOTO

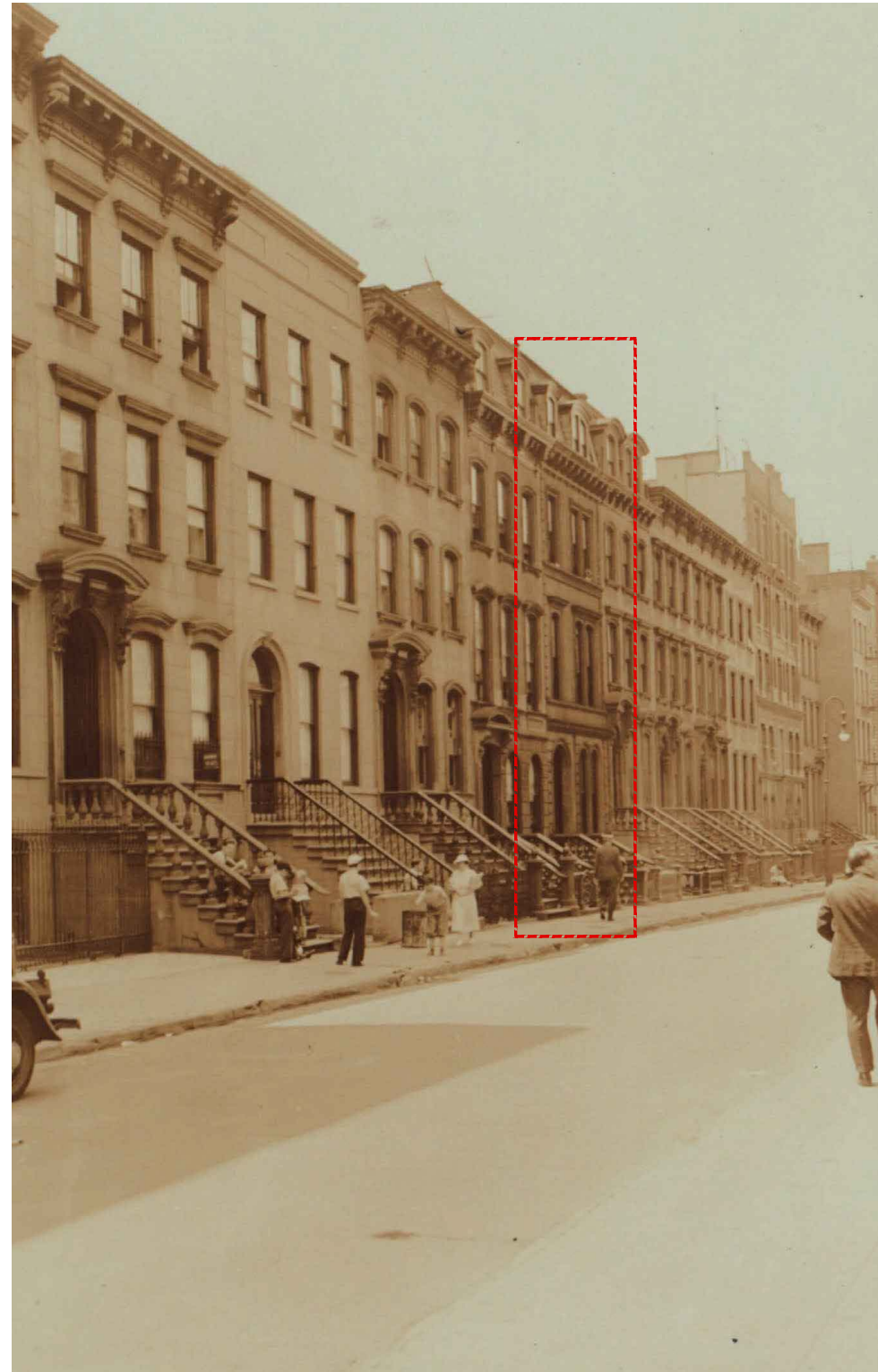

PERRY STREET LOOKING WEST, 1937



FRONT VIEW



DOOR - FRONT VIEW



DOOR - VIEW FROM OUTSIDE

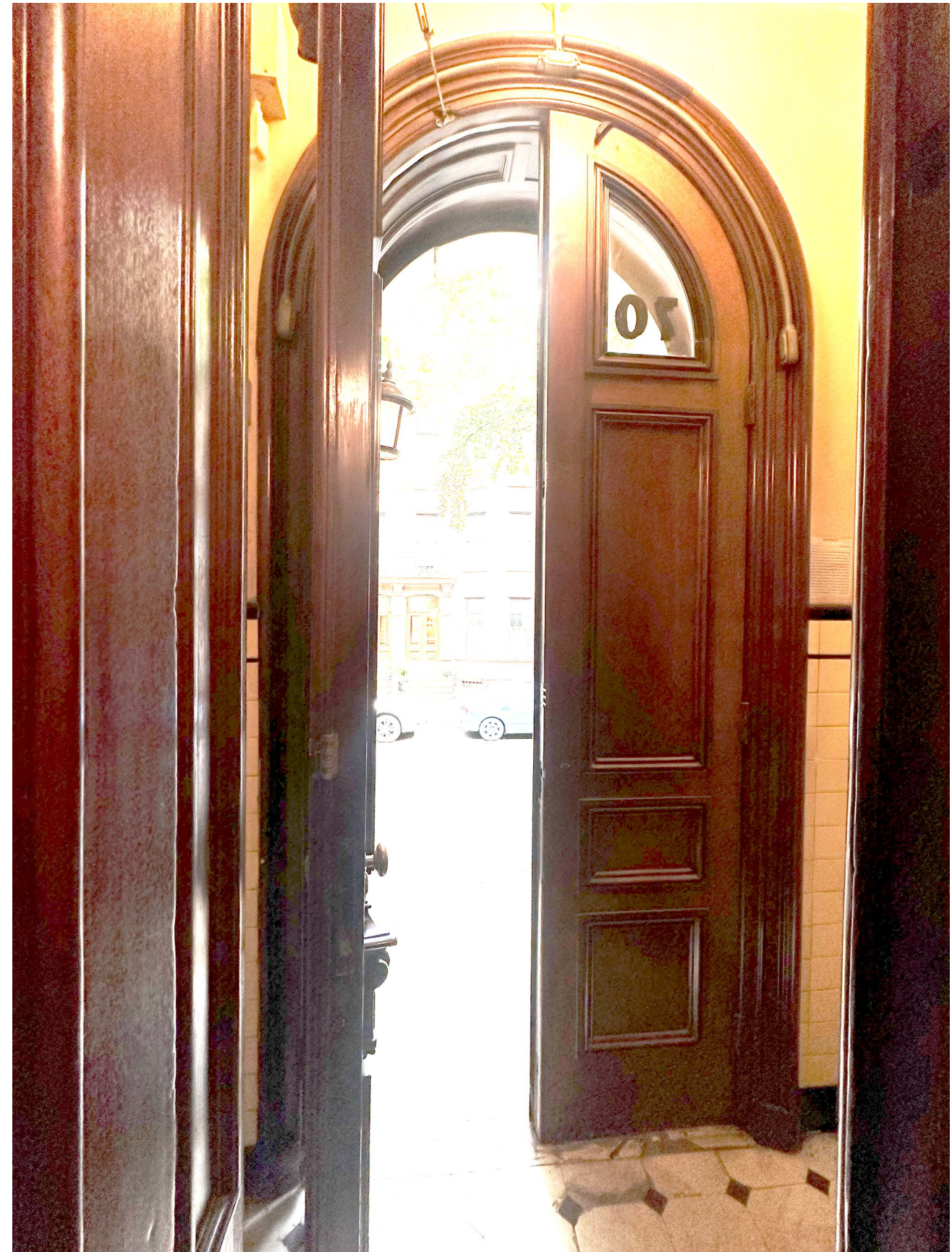

DOOR - VIEW FROM INSIDE



FRONT ELEVATION - EXISTING

REMOVE INTERIOR MOLDING AND WOOD PANEL



FRONT ELEVATION - PROPOSED

INSTALL GLASS PANEL AND INTERIOR MOLDING

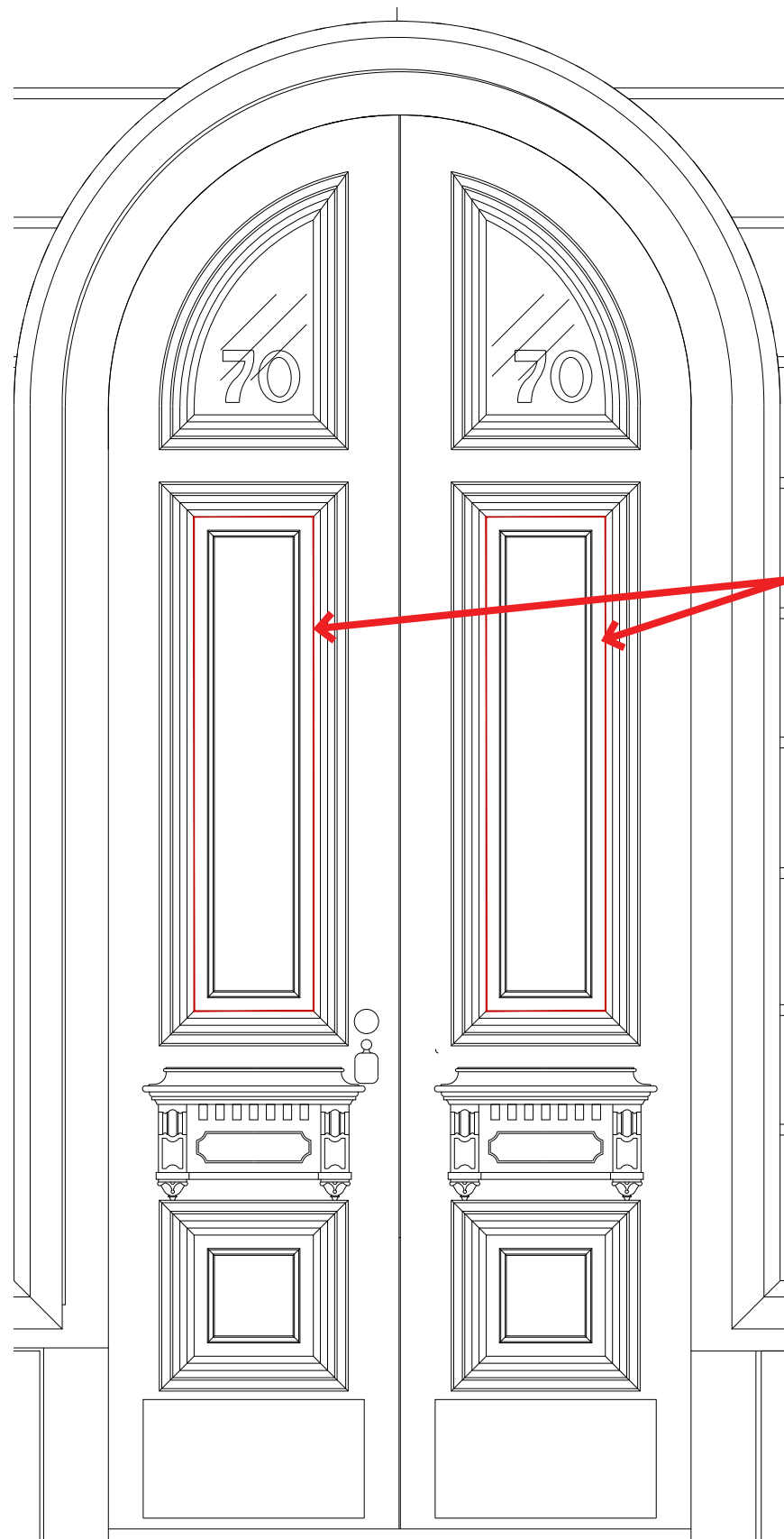

EXISTING - DOOR ELEVATION

REMOVE INTERIOR MOLDING
AND WOOD PANEL

INSTALL GLASS PANEL
AND INTERIOR MOLDING

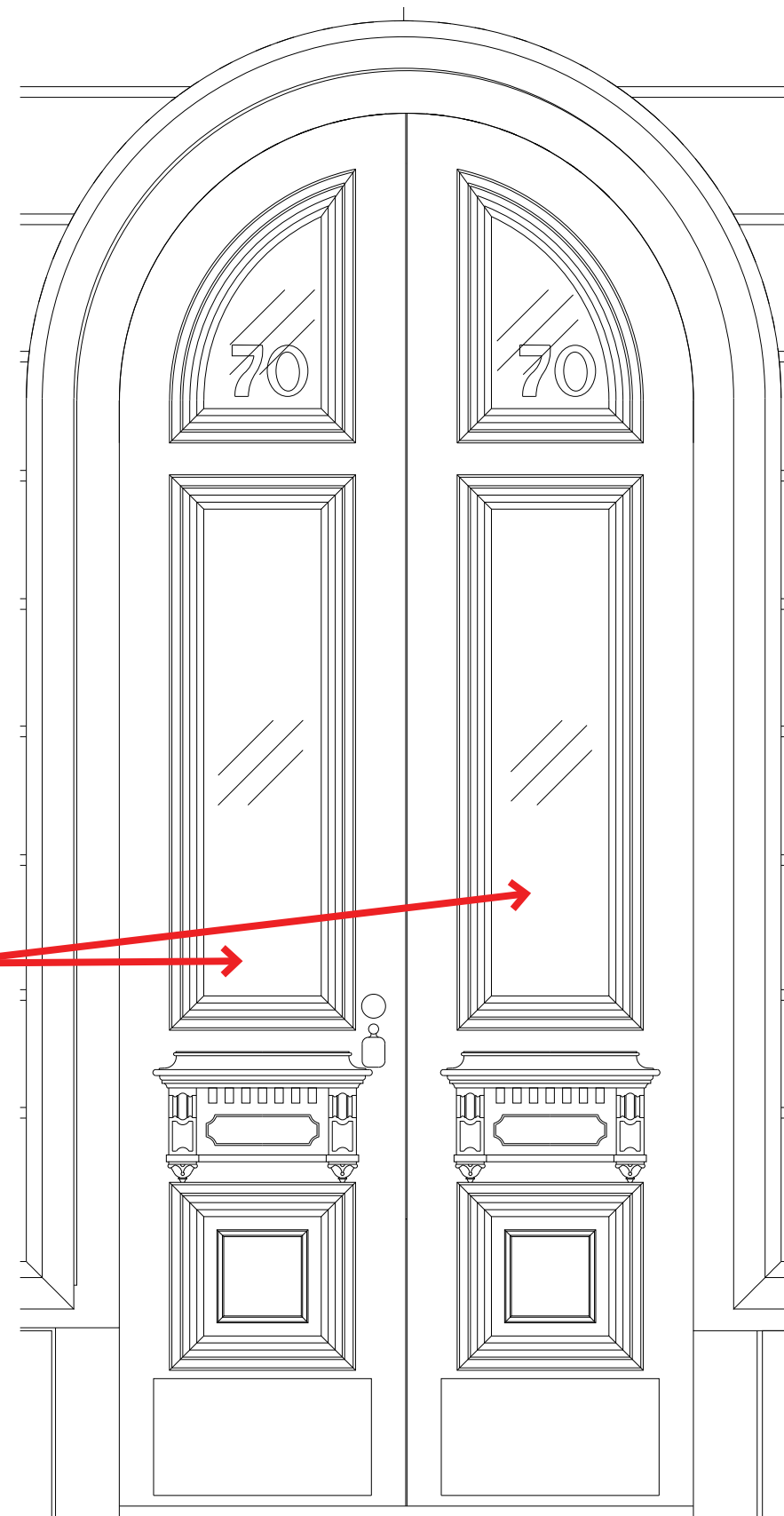

PROPOSED - DOOR ELEVATION

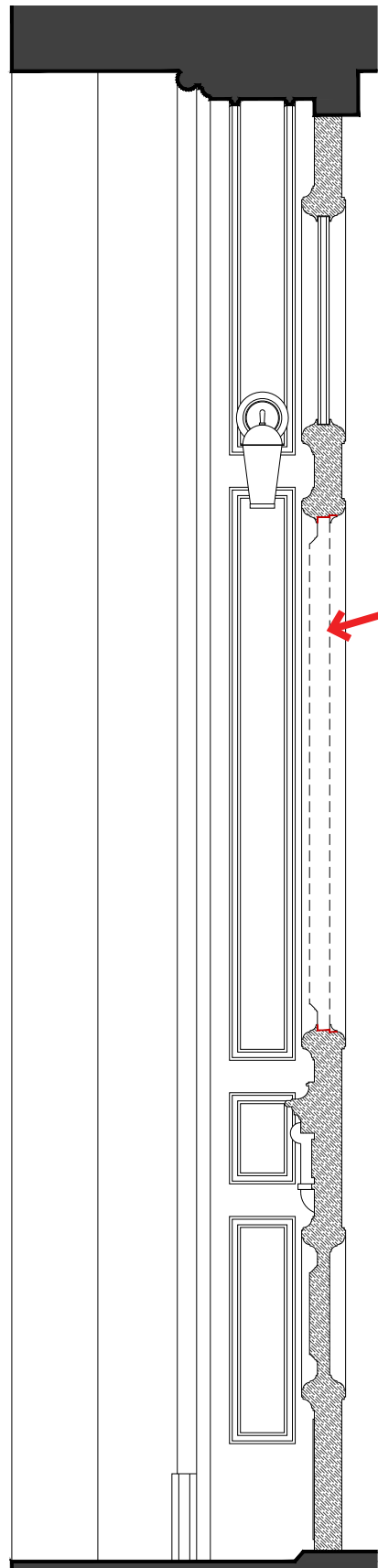

EXISTING - DOOR SECTION

REMOVE INTERIOR MOLDING
AND WOOD PANEL

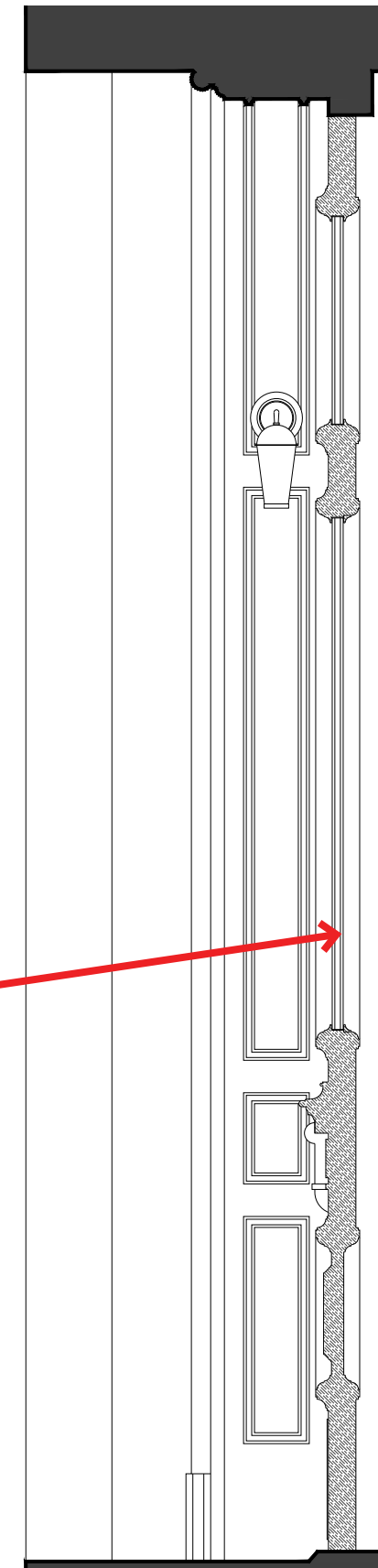

PROPOSED - DOOR SECTION

INSTALL GLASS PANEL
AND INTERIOR MOLDING

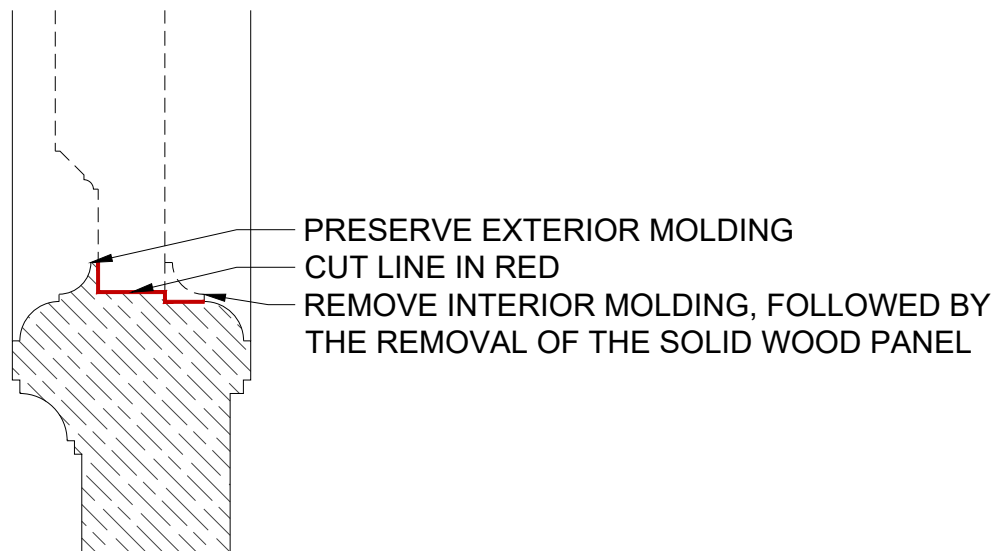

EXISTING - DOOR SECTION DETAIL

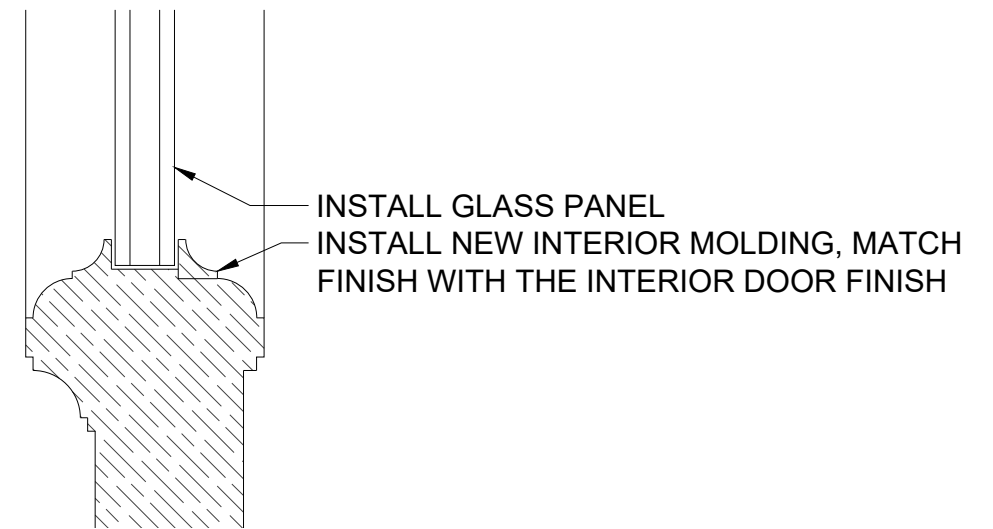

PROPOSED - DOOR SECTION DETAIL

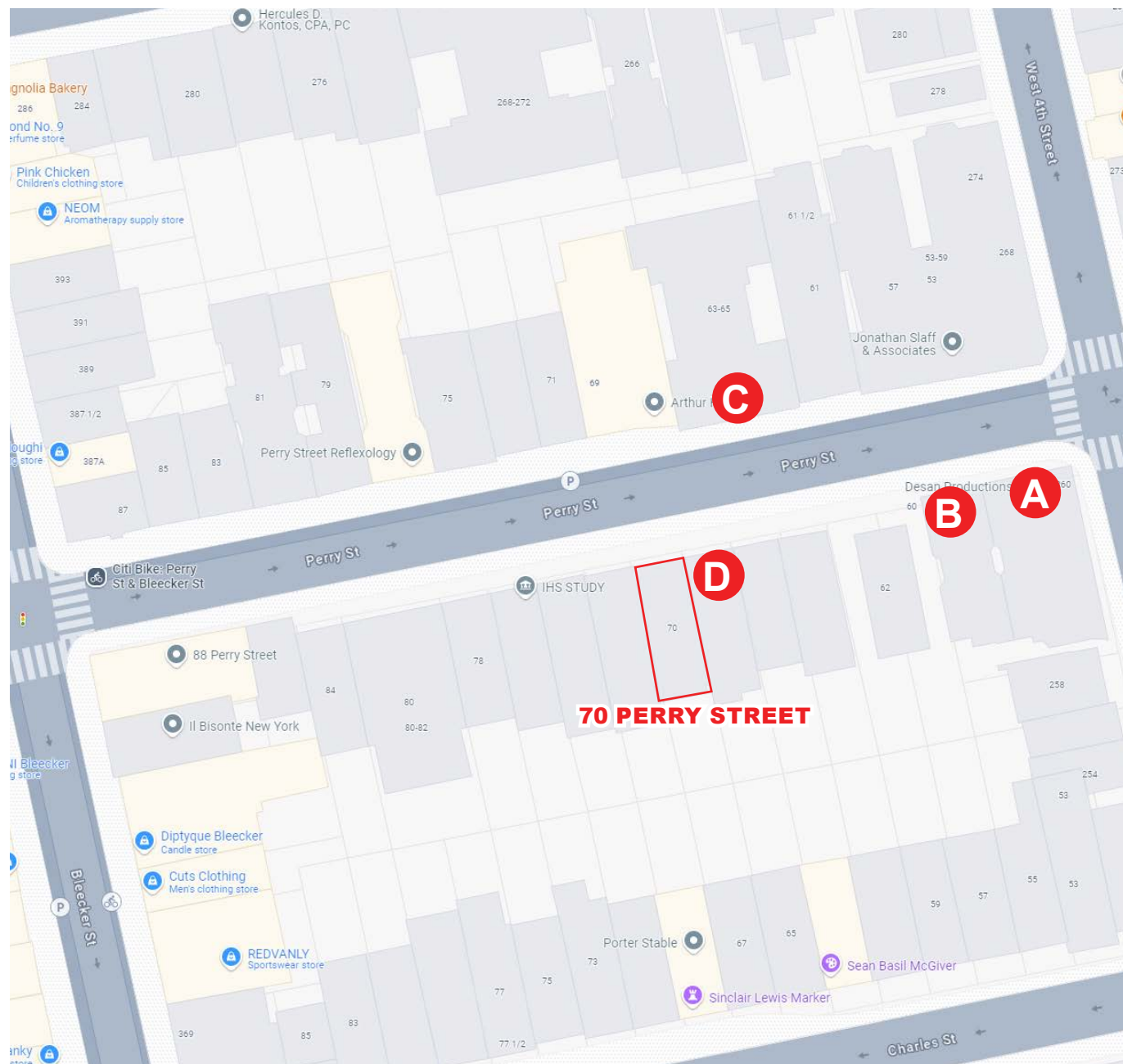

A. 56 PERRY STREET



B. 58 PERRY STREET



C. 63 PERRY STREET



D. 68 PERRY STREET



EXISTING DOOR



RENDERING - PROPOSED DOOR

October 29, 2024
Public Hearing

The current proposal is:

Preservation Department – Item 8, LPC-25-02666

70 Perry Street – Greenwich Village Historic District Borough of Manhattan

To testify virtually, please join Zoom

Webinar ID: 820 4014 2259

Passcode: 476351

By Phone: 646-558-8656 (NY)

877-853-5257 (Toll free) US

888-475-4499 (Toll free)

Note: If you want to testify virtually on an item, join the Zoom webinar at the agenda's "Be Here by" time (about an hour in advance). When the Chair indicates it's time to testify, "raise your hand" via the Zoom app if you want to speak (*9 on the phone). Those who signed up in advance will be called first.