

February 25, 2025  
Public Hearing

The current proposal is:

Preservation Department – Item 13, LPC-25-05481

**640 Park Avenue, aka 65-75 East 66th Street – Upper East Side**

**Historic District**

**Borough of Manhattan**

To testify virtually, please join Zoom

**Webinar ID:** 161 496 7153

**Passcode:** 846842

By Phone: 646-828-7666 (NY)

**Note:** If you want to testify virtually on an item, join the Zoom webinar at the agenda’s “Be Here by” time (about an hour in advance). When the Chair indicates it’s time to testify, “raise your hand” via the Zoom app if you want to speak (\*9 on the phone). Those who signed up in advance will be called first.

# WINDOW REPLACEMENT RESIDENCE OF THE SWISS CONSUL GENERAL

640 PARK AVENUE - 12TH FLOOR  
NEW YORK, NY 10065

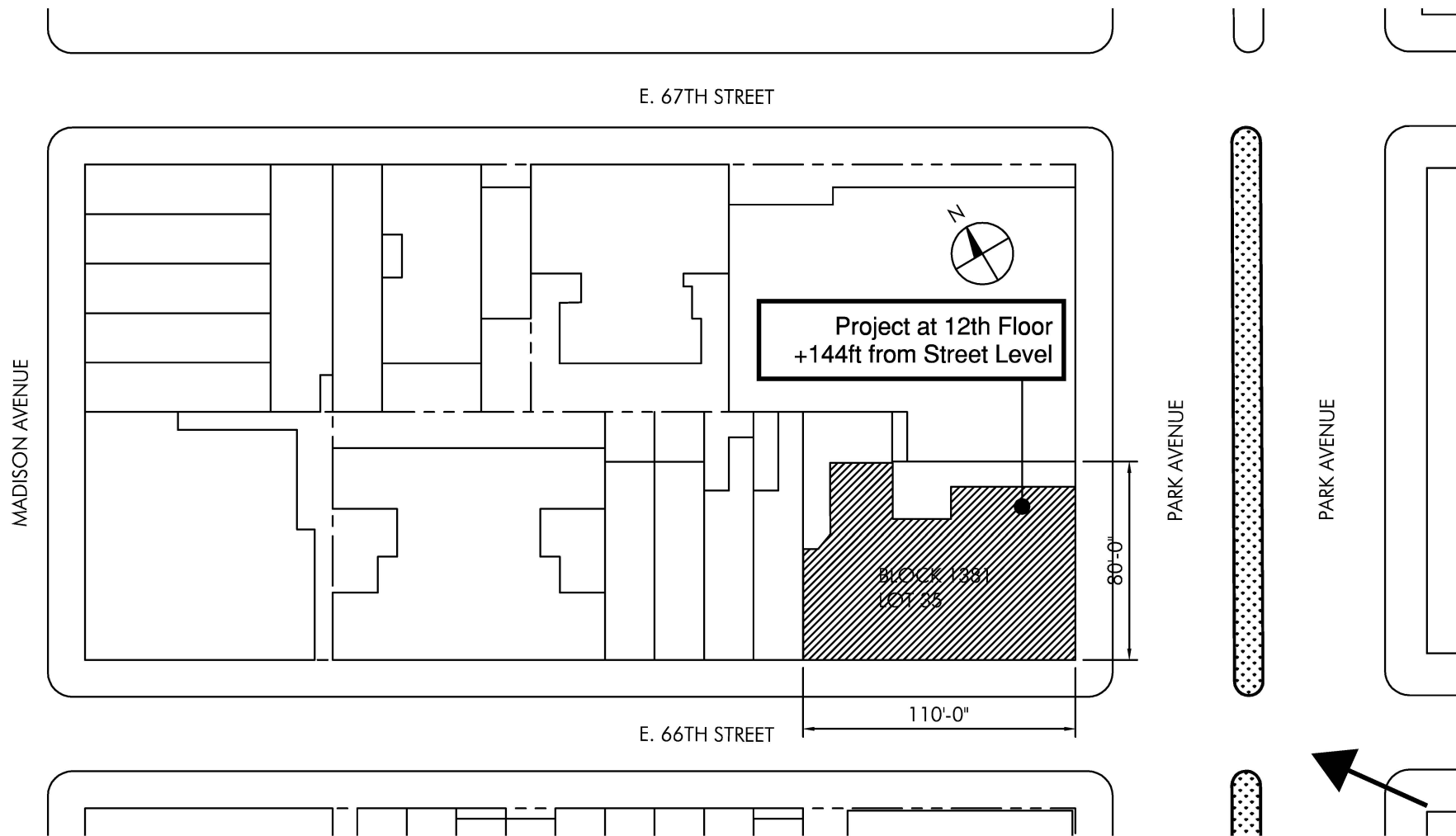

LOCATION PLAN



1940S TAX LOT PHOTO





VIEW D: LOOKING AT SOUTHWEST CORNER

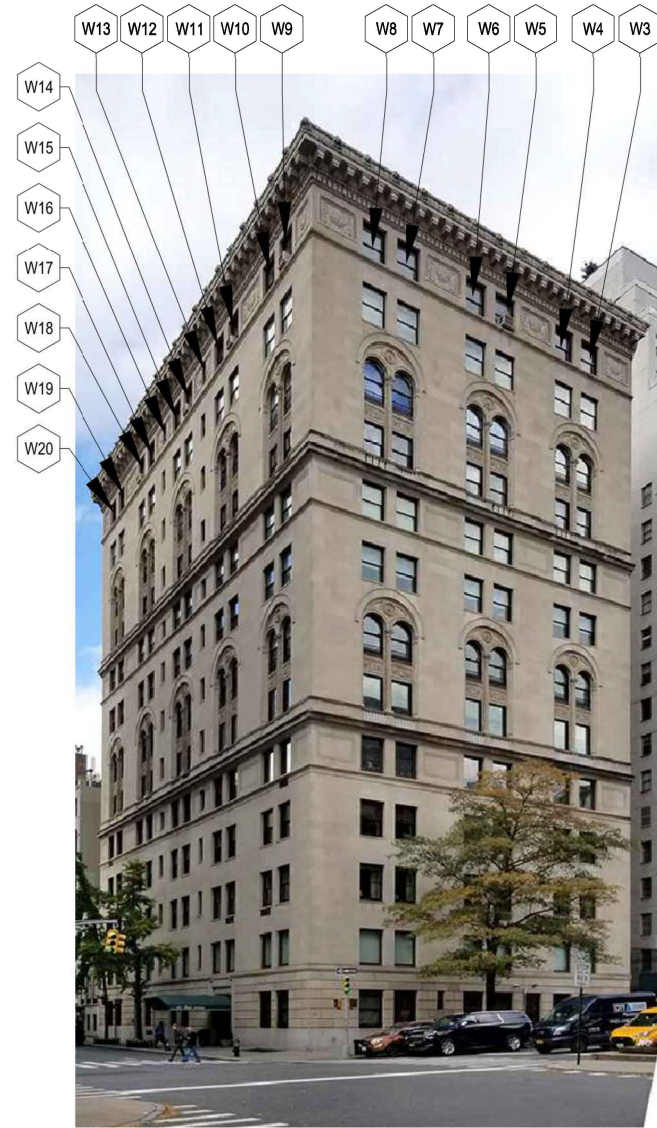

VIEW C : LOOKING AT SOUTHEAST CORNER



VIEW B : LOOKING AT NORTHEAST CORNER



VIEW A : LOOKING AT NORTHEAST CORNER

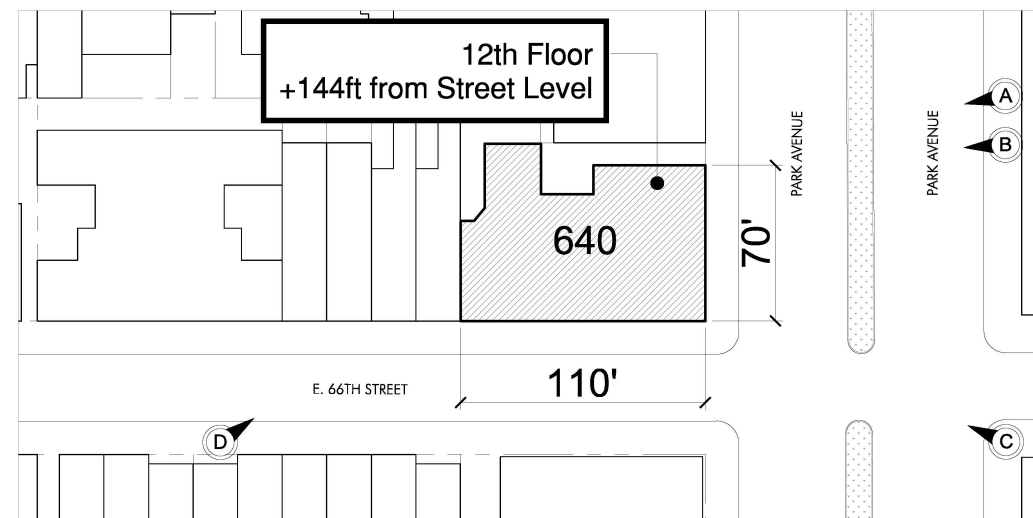





VIEW LOOKING SOUTH AT DEEP FENESTRATION OF EXISTING ALUMINUM REPLACEMENT WINDOWS



VIEW UP TOWARDS STRIKE & HEAD OF EXISTING ALUMINUM REPLACEMENT WINDOWS



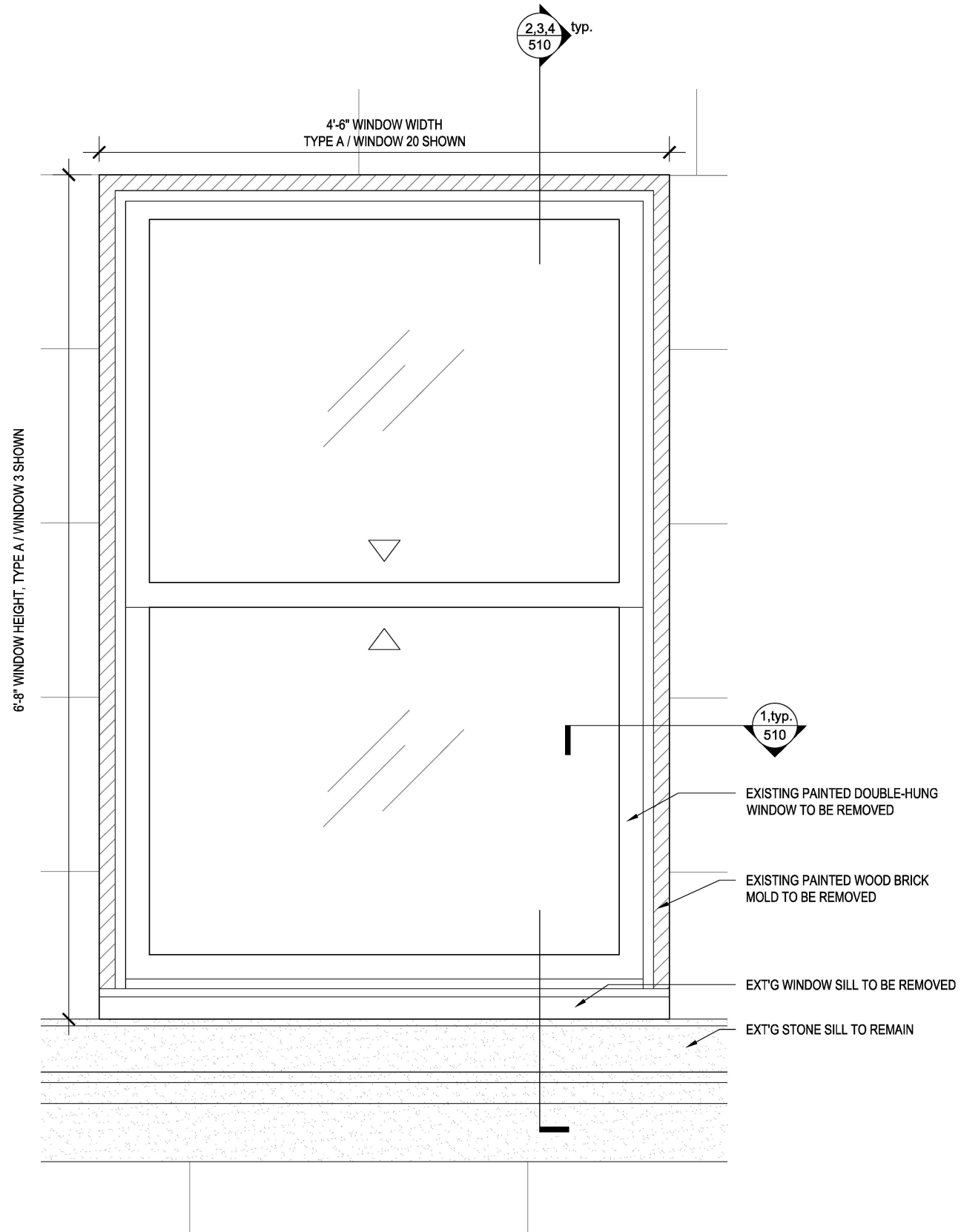

**EXISTING:**  
ELEVATION OF TYPICAL ALUMINUM REPLACEMENT DOUBLE HUNG WINDOW

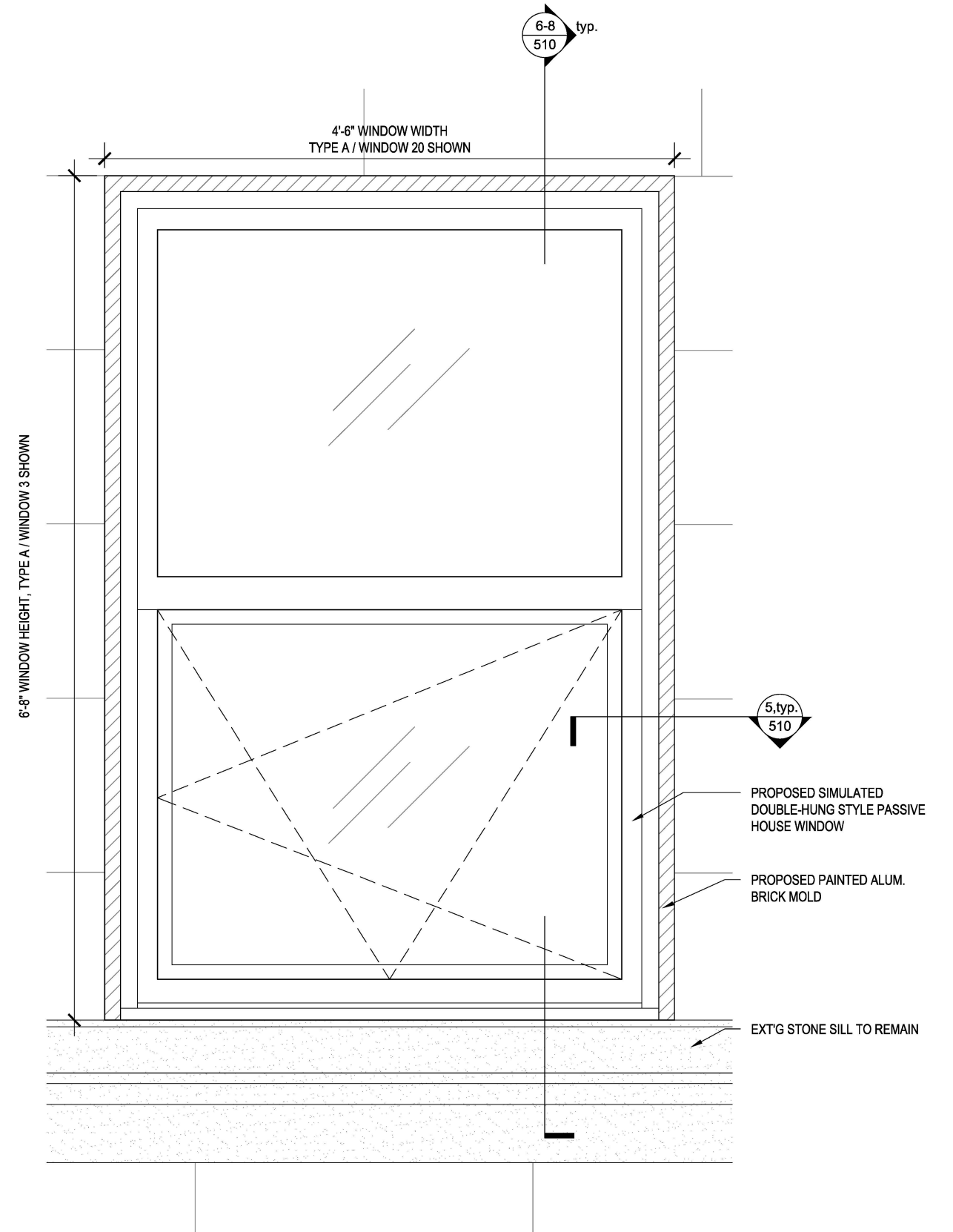

**PROPOSED:**  
ELEVATION OF TYPICAL SIMULATED DOUBLE HUNG WINDOW



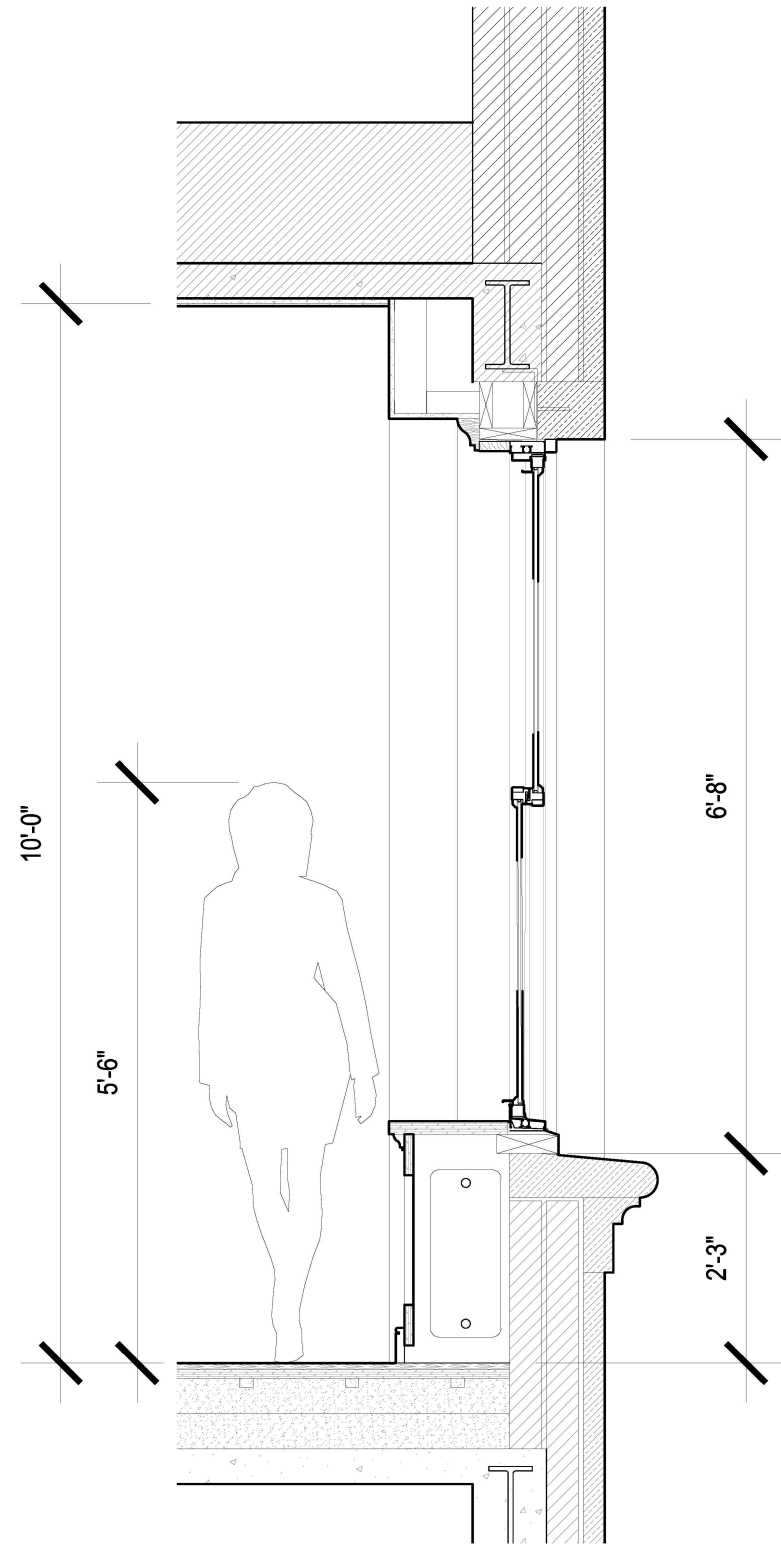

**EXISTING:**  
FULL HEIGHT SECTION DETAIL OF TYP. ALUMINUM REPLACEMENT DOUBLE-HUNG WINDOW

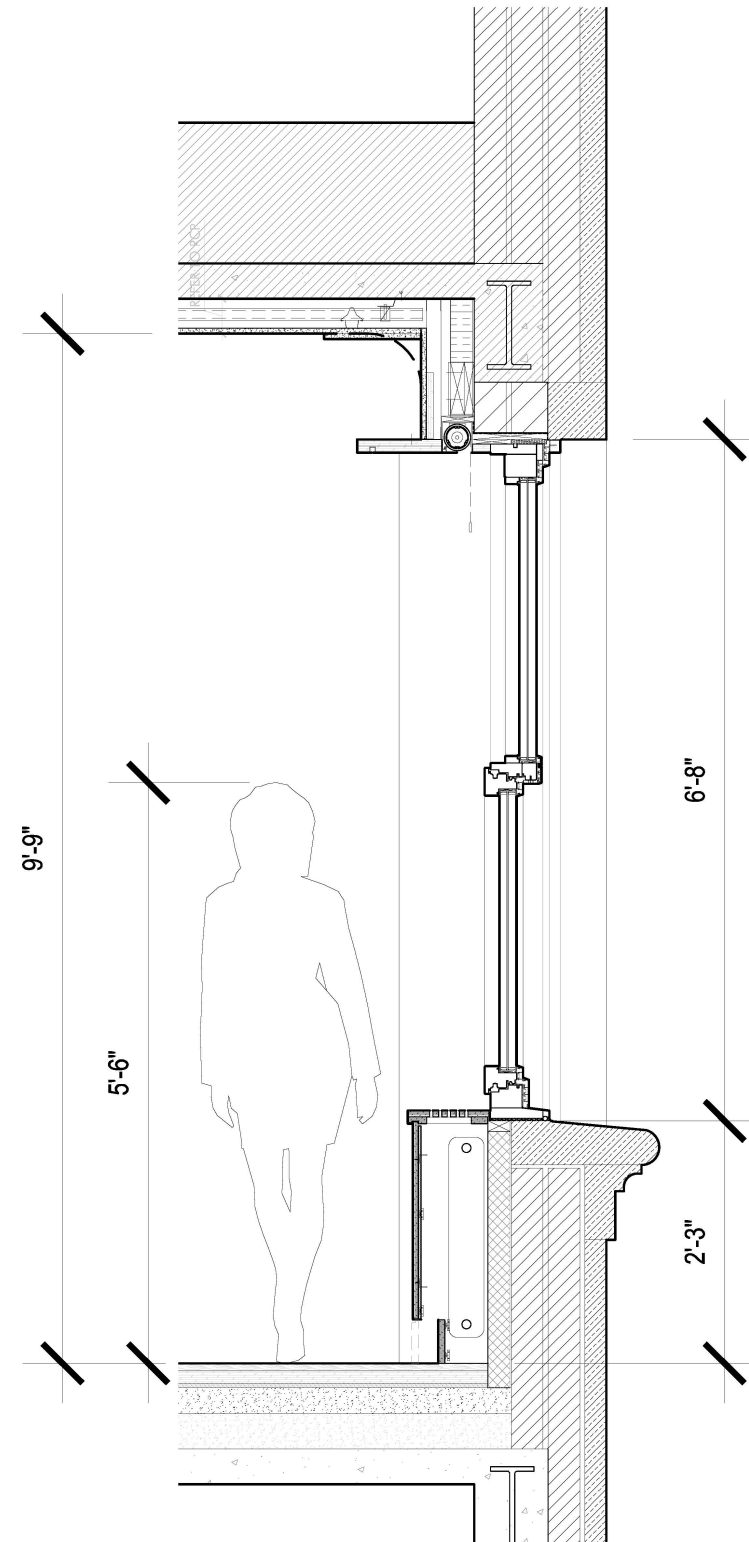

**PROPOSED:**  
FULL HEIGHT SECTION DETAIL OF TYP. SIMULATED DOUBLE-HUNG WINDOW



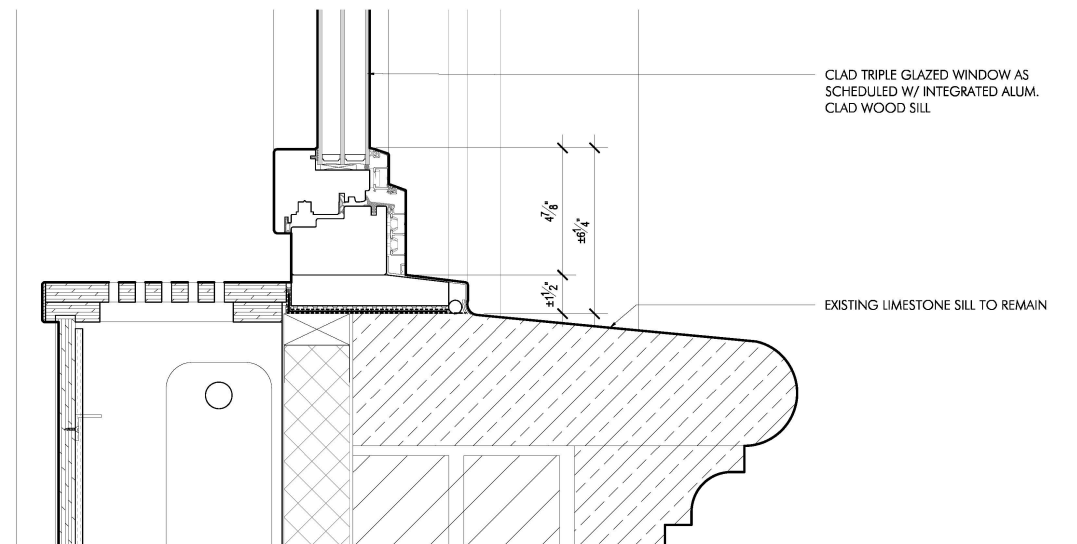
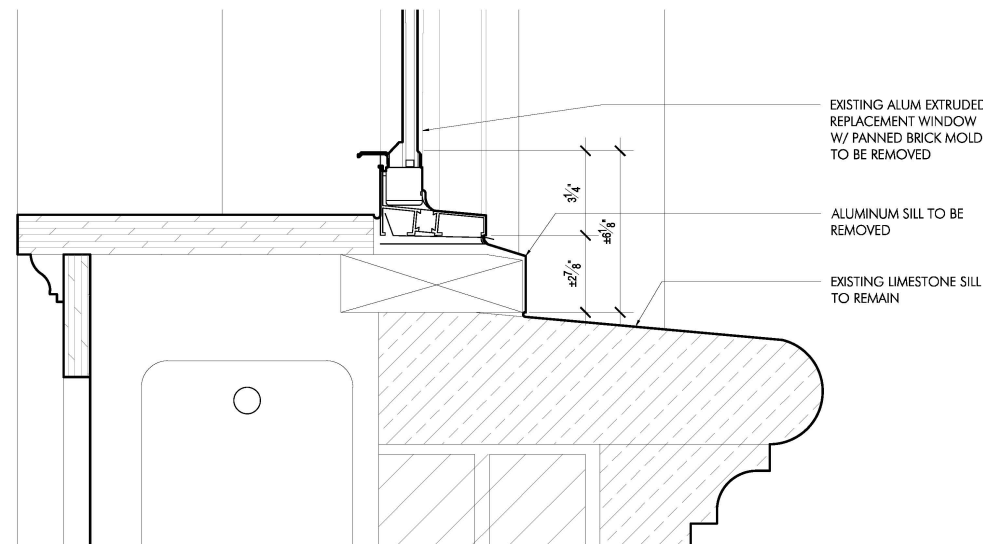
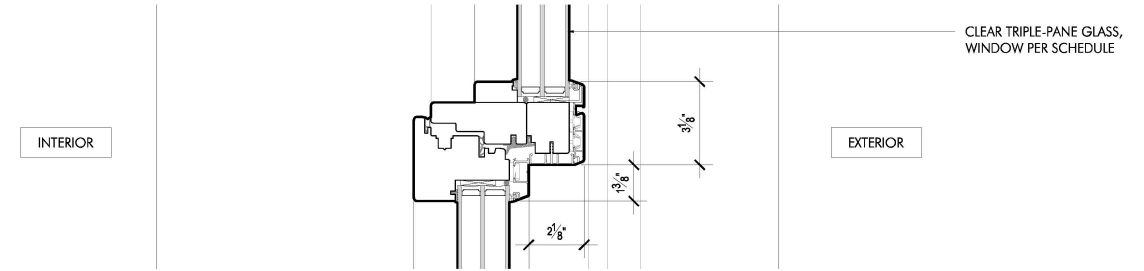
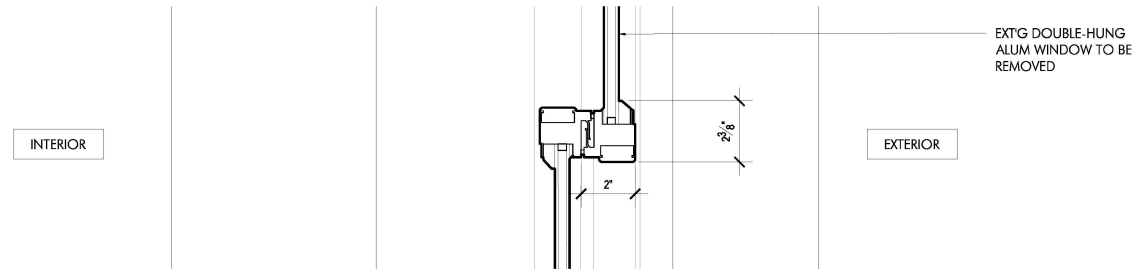
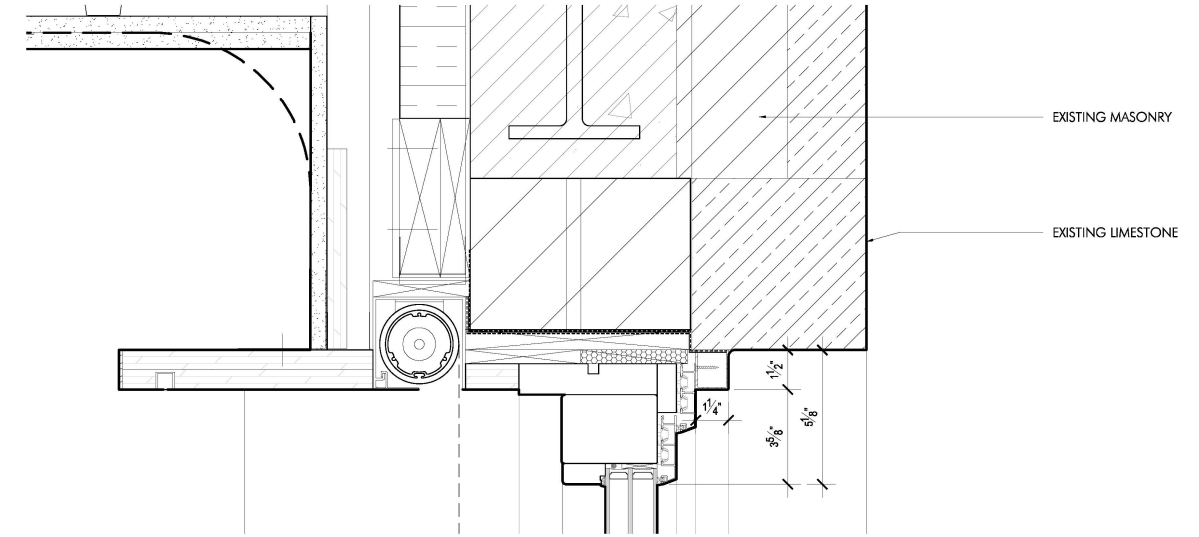
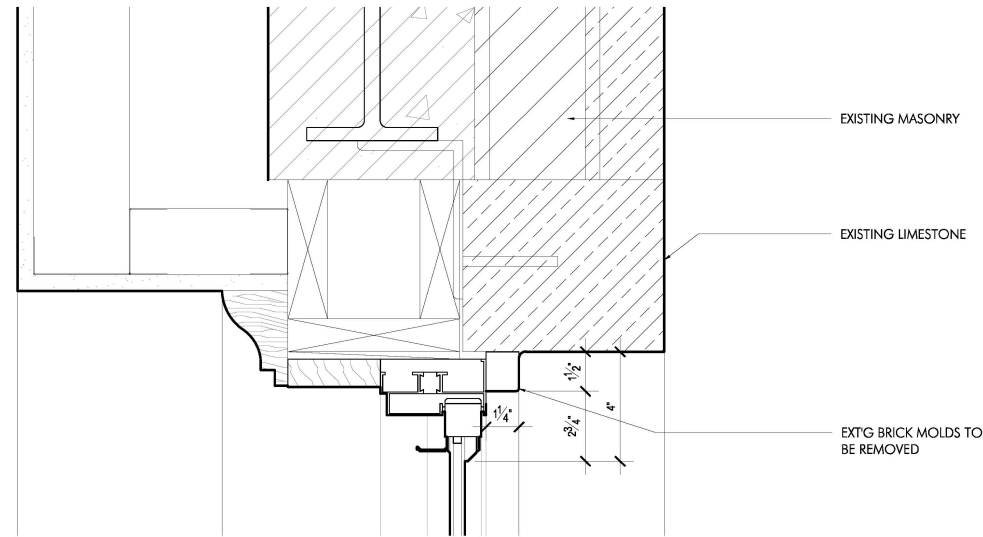

**EXISTING:**  
SECTION DETAIL OF TYPICAL ALUMINUM REPLACEMENT DOUBLE HUNG WINDOW

**PROPOSED:**  
SECTION DETAIL OF TYPICAL SIMULATED DOUBLE HUNG WINDOW



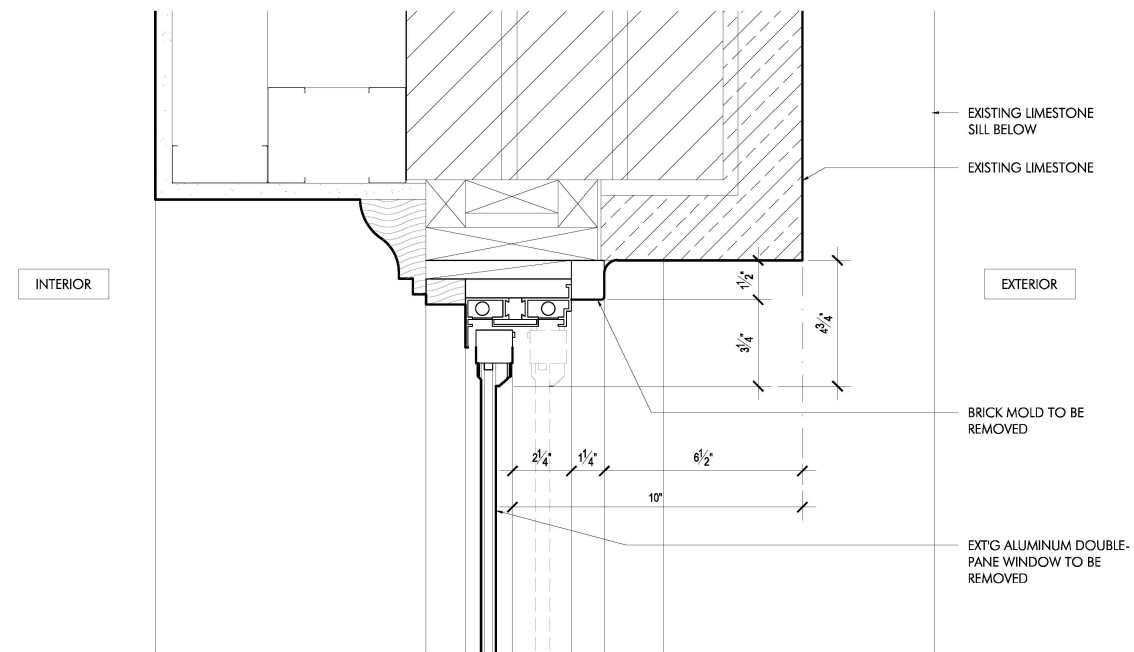

**EXISTING:**  
PLAN DETAIL OF TYPICAL ALUMINUM REPLACEMENT DOUBLE HUNG WINDOW  
@ LOWER LITE

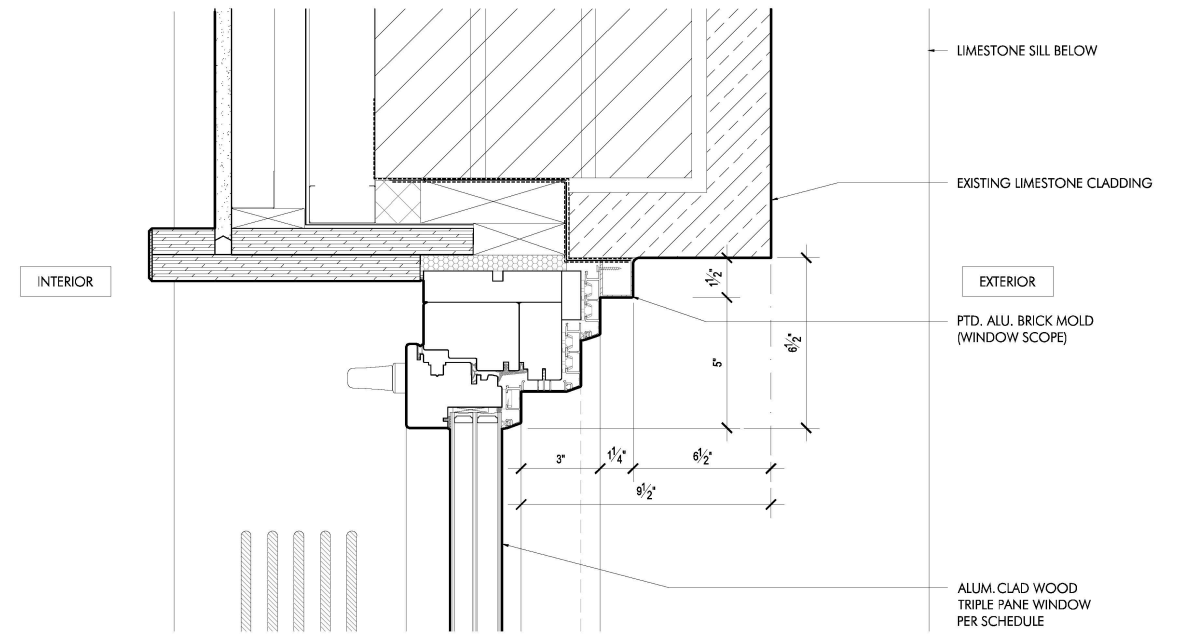

**PROPOSED:**  
PLAN DETAIL OF TYPICAL SIMULATED DOUBLE HUNG WINDOW  
@ LOWER LITE



**PROPOSED:**  
PHOTO OF SAMPLE WINDOW

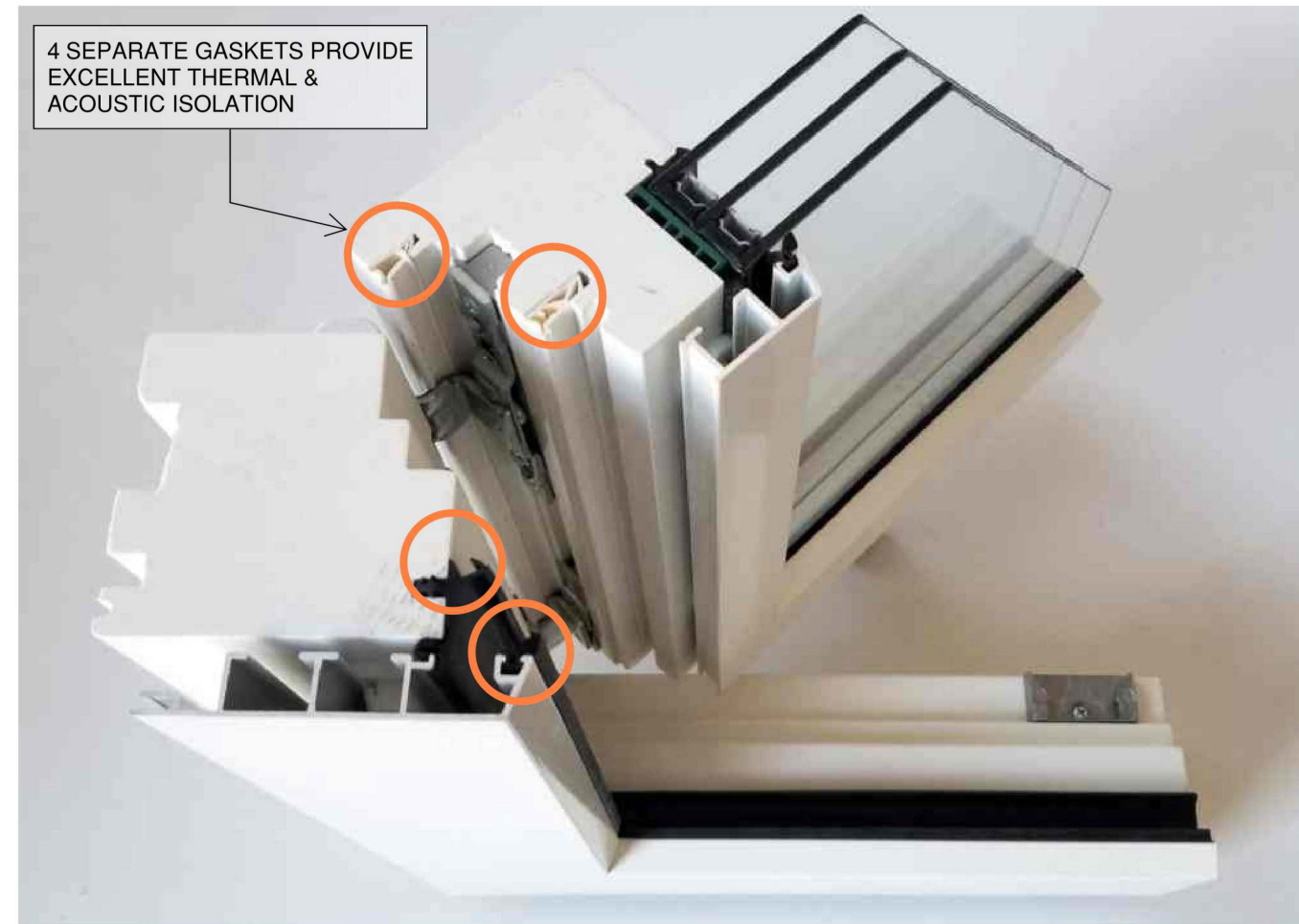

**PROPOSED:**  
PHOTO OF SAMPLE WINDOW FROM ABOVE



**PROPOSED:**  
WINDOW & BRICK MOLD COLOR  
RAL 9005 BLACK MATTE

February 25, 2025  
Public Hearing

The current proposal is:

Preservation Department – Item 13, LPC-25-05481

**640 Park Avenue, aka 65-75 East 66th Street – Upper East Side**

**Historic District**

**Borough of Manhattan**

To testify virtually, please join Zoom

**Webinar ID:** 161 496 7153

**Passcode:** 846842

By Phone: 646-828-7666 (NY)

**Note:** If you want to testify virtually on an item, join the Zoom webinar at the agenda’s “Be Here by” time (about an hour in advance). When the Chair indicates it’s time to testify, “raise your hand” via the Zoom app if you want to speak (\*9 on the phone). Those who signed up in advance will be called first.