



The City of New York

# Manhattan Community Board 1

**Monthly Board Meeting**  
**Tuesday, October 22, 2024**  
**6:00PM**

1 Centre Street, 19<sup>th</sup> Floor - Southside  
Manhattan Borough President's Office  
and [Live Remote Meeting](#)

The public is welcome to attend in person or on Webex

Tammy Meltzer, Chairperson  
Alice Blank, Vice Chairperson  
Zach Bommer, District Manager  
Lucy Mujica Diaz, Community Coordinator  
Onedeige James, Community Associate



"All meetings are recorded to the extent practicable and posted on our Youtube page as soon as possible. You may find the link [here.](#)"

"If there are any relevant draft resolutions that will be considered at this meeting, they may be found [here.](#)"

# OFFICE CONTACT

Manhattan Community Board 1  
1 Centre Street, Room 2202 North New York, NY 10007  
Tel: (212) 602-6300

Website: [nyc.gov/mcb1](https://nyc.gov/mcb1) Email: [Man01@cb.nyc.gov](mailto:Man01@cb.nyc.gov)

The Manhattan Community Board 1 office is open, but you must email us to set up an appointment. Please use [man01@cb.nyc.gov](mailto:man01@cb.nyc.gov) as the principal means of communication with staff .



# MANHATTAN COMMUNITY BOARD 1

## Public Session (6:00 PM – 7:00 PM)

A) Comments by members of the public  
(1-2 minutes per speaker)



# MANHATTAN COMMUNITY BOARD 1

---

## Public Hearing

Topic: Community Input for City Expense & Capital Budget Priorities for CB1 FY 2025 - FY 2026



# MANHATTAN COMMUNITY BOARD 1

## Business Session

- A) Adoption of September 2024 minutes
- B) Updates from Elected Officials
- C) Treasurer's Report - M. James
- D) District Manager's Report – Z. Bommer
- E) Chairperson's Report – T. Meltzer





# MANHATTAN COMMUNITY BOARD 1

## Treasurer's Report

### Community Board #1 Treasurer's Report

Fiscal Year 2025 as of September 30, 2024  
July 1, 2023 to June 30, 2024

OMB Budget Submitted by Mariama James, Treasurer on October 22, 2024

Spending Category	Budget	1st Qtr. 7-1 to 9-30	Unexpended Balance
-------------------	--------	-------------------------	-----------------------

Telephone	\$1,245.00	\$1,245.00	\$0.00
General Supplies	\$2,000.00	\$109.97	\$1,890.03
Food	\$2,000.00	\$454.96	\$1,545.04
Cleaning Supplies	\$2,000.00	\$0.00	\$2,000.00
Data Supplies	\$4,000.00	\$0.00	\$4,000.00
Data Processing Equipment	\$4,200.00	\$0.00	\$4,200.00
Printing	\$400.00	\$0.00	\$400.00
Travel	\$2,000.00	\$90.36	\$1,909.64
Leasing	\$300.00	\$0.00	\$300.00
Service Contract/Office Equipment Maintenance	\$3,000.00	\$0.00	\$3,000.00
Advertising	\$100.00	\$0.00	\$100.00
Personnel Services	\$267,484.00	\$55,889.00	\$211,595.00
<b>Totals</b>	<b>\$288,729.00</b>	<b>\$57,789.29</b>	<b>\$230,939.71</b>

#### Street Fair Fundraising

Spending Category	Budget	1st Qtr. 7-1 to 9-30	Unexpended Balance
To be scheduled	\$128,194.00	\$500.00	\$127,694.00
Data Processing Equipment	\$0.00	\$0.00	\$0.00
Donation	\$0.00	\$0.00	\$0.00
Travel	\$0.00	\$0.00	\$0.00
General Supplies	\$0.00	\$0.00	\$0.00
Food	\$0.00	\$0.00	\$0.00
Temp. Service	\$0.00	\$0.00	\$0.00
<b>Totals</b>	<b>\$128,194.00</b>	<b>\$500.00</b>	<b>\$127,694.00</b>

### Community Board #1 Treasurer's Report

Fiscal Year 2025 as of September 30, 2024  
July 1, 2023 to June 30, 2024

Grants Submitted by Mariama James, Treasurer on October 22, 2024

Spending Category	Budget	1st Qtr. 7-1 to 9-30	Unexpended Balance
-------------------	--------	-------------------------	-----------------------

To be determined	\$0.00	\$0.00	\$0.00
Office Equipment	\$4,000.00	\$2,516.87	\$1,483.13
Consultant Contract	\$2,000.00	\$1,831.75	\$168.25
<b>Totals</b>	<b>\$6,000.00</b>	<b>\$4,348.62</b>	<b>\$1,651.38</b>



# MANHATTAN COMMUNITY BOARD 1

## District Manager's Report October 2024

**NYC** DESIGN



Public Design Commission - [Tours of Archives and City Hall](#) - Including exhibit “Undesign the Redline”

Mayor's Office of Contract Services [Public Hearing](#)

Thursday, October 24, 2024 at 10:00 AM

Contract between the DHS and Breaking Ground for Safe Haven at  
320 Pearl Street

# MANHATTAN COMMUNITY BOARD 1

## 23 Lights out on Hudson River Greenway



November Scheduling Changes:

Land Use - Monday Nov 4th (Veterans Day)

Full Board - Monday Nov 25th (Thanksgiving Travel Accommodation)



# MANHATTAN COMMUNITY BOARD 1

## Chairperson's Report October 2024





# OCTOBER UPDATES

## SINCE LAST MEETING -The Chair has been at the following....

- SEPT 25 - 105 Washington/PS 150 Meeting
- SEPT 26 - HRPT Board Meeting - Exciting Updates & Research
- SEPT 30 - ADNY Board Meeting - 7 New Conversions
- OCT 01 - Website Update Meeting
- OCT 08 - LETTER RE: Public Access Battery Maritime Building
- OCT 08 - Governors Island Gala
- OCT 11 - CCLM Chair Update
- OCT 15 - CBS NEWS ON COY
- OCT 16 - 1ST PRECINCT CC - CAPTAIN INTERVIEWS
- OCT 17 - BOROUGH BOARD/DCAS Expo/  
Port Authority Follow Up-Vesey Street & Bus

### Parking

- OCT 18 - CCLM PREVIEW
- OCT 21 - CCLM - FIDI SEAPORT MASTER PLAN  
PUBLIC TESTIMONY

Beautiful  
Spaces  
for  
Events



Photos by TAM

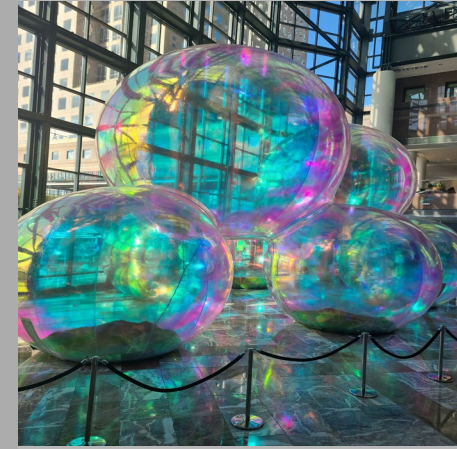

Art is fun!



Non-  
existent  
traffic  
enforcement





# 2024 CHAMPIONSHIP CELEBRATIONS *thru* OCTOBER 24

## 10 AM VICTORY PARADE

CANYON OF HEROES 📍  
MANHATTAN  
Free & Open to the Public

## IMMEDIATELY POST-PARADE CITY HALL CEREMONY

CITY HALL 📍  
MANHATTAN  
Ticketed Event\*

## 7-10PM CHAMPIONSHIP CELEBRATION

BARCLAYS CENTER 📍  
BROOKLYN  
Free & Open to the Public  
Ticketed Event\*

\*sign up to be contacted about ticketing information for events



[Ticket link](#)

NYC ticker-tape parade route, Thursday, October 24th  
The parade will tip off at 10 a.m. from Battery Park and proceed north along Broadway to City Hall through the Canyon of Heroes. A ceremony at City Hall honoring the Liberty will follow the parade at noon. The team will also host a celebration with fans at Barclays Center in Brooklyn at 7 p.m.



#	Location	Street Closure	Street Side	Closure
Formation				
1	BATTERY PLACE between WEST THAMES STREET and BROADWAY	Full Street Closure	Full	Public
2	3 PLACE between BATTERY PLACE and LITTLE WEST STREET	Full Street Closure	Full	Private
3	2 PLACE between BATTERY PLACE and LITTLE WEST STREET	Full Street Closure	Full	Public
4	LITTLE WEST STREET between 3 PLACE and BATTERY PLACE	Full Street Closure	Full	Public
5	WEST STREET between MORRIS STREET and BATTERY PLACE	Full Street Closure	Full	Public
6	MORRIS STREET between WEST STREET and WASHINGTON STREET	Full Street Closure	Full	Public
7	STATE STREET between BATTERY PLACE and BRIDGE STREET	Full Street Closure	Full	Public
8	WEST THAMES STREET between SOUTH END AVENUE and WEST STREET	Full Street Closure	Full	Public
9	GREENWICH STREET between MORRIS STREET and BATTERY PLACE	Full Street Closure	Full	Public
10	1 PLACE between BATTERY PLACE and LITTLE WEST STREET	Full Street Closure	Full	Public
Route				
1	BROADWAY between BATTERY PL and CHAMBERS STREET	Full Street Closure	Full	Public
Dismissal				
1	CHAMBERS STREET between BROADWAY and CENTRE STREET	Full Street Closure	Full	Public
2	READE STREET between CHURCH STREET and LAFAYETTE STREET	Full Street Closure	Full	Public
3	DUANE STREET between CHURCH STREET and BROADWAY	Full Street Closure	Full	Public
4	THOMAS STREET between CHURCH STREET and BROADWAY	Full Street Closure	Full	Public
5	BROADWAY between CHAMBERS STREET and THOMAS STREET	Full Street Closure	Full	Public
6	LAFAYETTE STREET between WORTH STREET and CENTRE STREET	Full Street Closure	Full	Public
7	CENTRE STREET between CHAMBERS STREET and READE STREET	Full Street Closure	Full	Public

# What streets are affected?



# UPCOMING...

- **HOT OFF THE PRESSES**
  - **THURSDAY - CANYON OF HEROES PARADE FOR NY LIBERTY!!**  
(PS 150 and PSIS 276 have been notified)
  - **FRIDAY NOON - Need a CB1 Volunteer to attend the SPCR Percent for Art Program** (notice came in 2 hrs before the meeting)
- **Due to the Holidays in November Many meetings have moved - including Full Board - now on Monday 11/25**
- **Chinatown Connections Working Group Meeting #4 (TBD)**
- **FIDI Seaport Master Plan Update is EPC in November - MAJOR CHANGES - PLEASE SHARE AND ATTEND...**





SIGN UP BY SCANNING QR CODE

# MANHATTAN LEADERSHIP TRAINING SERIES

Learn about local government processes from experts in this series of leadership training workshops led by the Office of Manhattan Borough President Mark Levine - it only happens once a year!

If you are a member of Manhattan's Community Boards, be sure to attend all required Leadership Training Series workshops.

## OCTOBER 28TH, 2024

12PM • Open Data w/ BetaNYC

5PM • Conflict of Interest Board (COIB)  
*Required for Community Board Members*

## OCTOBER 29TH, 2024

12PM • Combatting Implicit Bias  
*Required for Community Board Members*

5PM • Understanding Affordable Housing Financing

## OCTOBER 30TH, 2024

5PM • Equal Employment Opportunity (EEO)  
*Required for Community Board Members*

## OCTOBER 31ST, 2024

5PM • Basic Land Use & Zoning

## NOVEMBER 1ST, 2024

12PM • Emergency Readiness & NYC Office of Emergency Management  
*In-person event, please register in advance at [eventbrite.com/e/emergency-readiness-nycoem-training-tickets-1049018481517](https://eventbrite.com/e/emergency-readiness-nycoem-training-tickets-1049018481517)*

For more info visit [manhattanbp.nyc.gov/resources/community-leadership-training-series/](https://manhattanbp.nyc.gov/resources/community-leadership-training-series/)



^ required for CB Members^

SHARING NEWS!  
SEND US UPDATES!

FIDI SEAPORT MASTER PLAN SUBSTANTIAL CHANGES - USCG, PIER 15 & PIER 19(?!) & POTENTIAL FOR 6 NEW BUILDINGS...

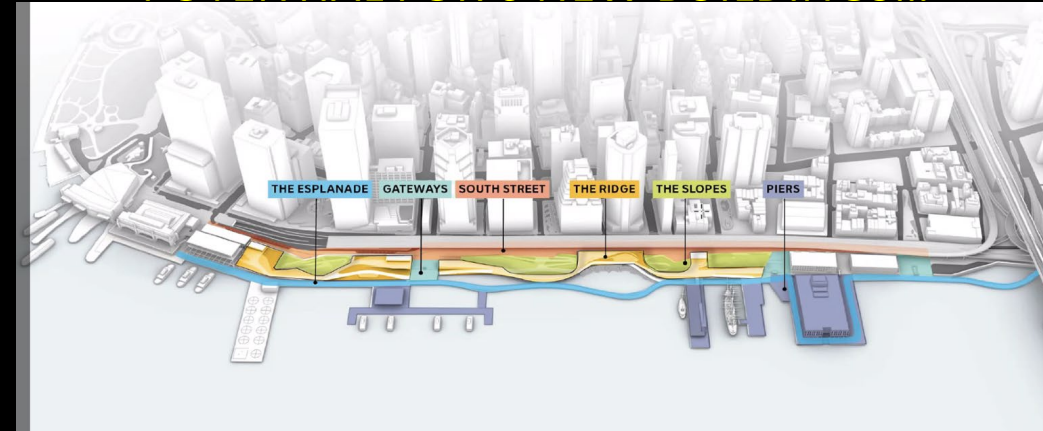

aka Birthdays and honors

ERIC FLORES BEING HONORED TONIGHT



New York County Lawyers Association  
New York State Bar Association  
New York State Unified Court System's Office for Justice Initiatives

# Happy Halloween !!

Have a safe and fun holiday... please send us photos to share next month!

CB1 Halloween Pumpkins and Costumes!

(yes these are from my house)



# MANHATTAN COMMUNITY BOARD 1



## Executive Committee - T. Meltzer

1. 108-119 South Street - Green Klub Inc, Microbusiness - Resolution
2. 253 Broadway - Stoned in Brooklyn INC – Resolution
3. 85 West Broadway, application for sidewalk cafe at Smyth Tavern LLC dba Smyth Tavern – Resolution
4. Capital and Expense Budget Items for FY 2026 – Resolution





# MANHATTAN COMMUNITY BOARD 1

## Youth & Education Committee - T. Joyce



1. \$5 Citibike for Students - Report
2. Battery Park City Ball Fields Padding and Turf Replacement - Report
3. Sighting of Safe Haven Shelters near schools - Report





**Battery Park  
City Authority**

# **BPC BALL FIELDS REPAIRS & UPGRADES**

MANHATTAN CB1: YOUTH & EDUCATION COMMITTEE

OCTOBER 8, 2024



# BALLFIELD REPAIRS AND UPGRADES: SCOPE

- Replacing the padding around the field perimeter and light poles
- Replacing the turf and its component parts (recycle if possible, per BPCA guidelines)
- Additional netting to protect seating / observation areas
- New batting cages and outfield fencing
- Weatherproofing of the dugout roofing
- Repairing the two backstops
- Removing the existing, unusable water cannons and replacing them with misters
- Removing existing bioswale (due to maintenance considerations) and replacing it with additional square footage of turf
- Removing five trees (for player safety) and reducing the mulch bed
- Replacing existing pavers along the Ball Fields' pedestrian path and between dugouts with new permeable pavers





# BALLFIELD REPAIRS AND UPGRADES: SCHEDULE CONSIDERATIONS

## Schedule Milestones

September:	RFP posted
October:	Vendor selected and approved
November:	Contract executed; pre-construction
December:	Pre-construction; on-site work starts (fields closed)
January:	Construction (fields closed)
February:	Construction (fields closed)
March:	Downtown Little League pre-season
April:	Downtown Little League Opening Day

## Schedule Goal

Ensuring work is complete for Downtown Little League's Opening Day and preceding practices (ideally by March 1), and the fields remain open through the weekend after Thanksgiving.

## Schedule Risks

- Weather (snow)
- Materials delay
- Contractor manpower shortages

*We will have greater clarity and confidence re: schedule once we onboard a contractor.*

*We will provide regular updates to DLL leadership.*



# MANHATTAN COMMUNITY BOARD 1

## Waterfront, Parks & Cultural Committee - A. Zelter

### 1. Barnett Newman Triangle Plaza Presentation - Resolution

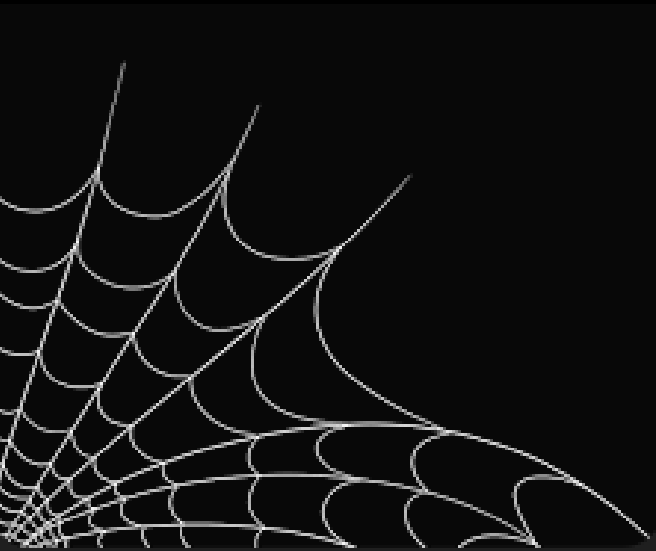



# 1. Site of triangle at Church, 6th Ave and White street converge





## 2. BNT today looking south





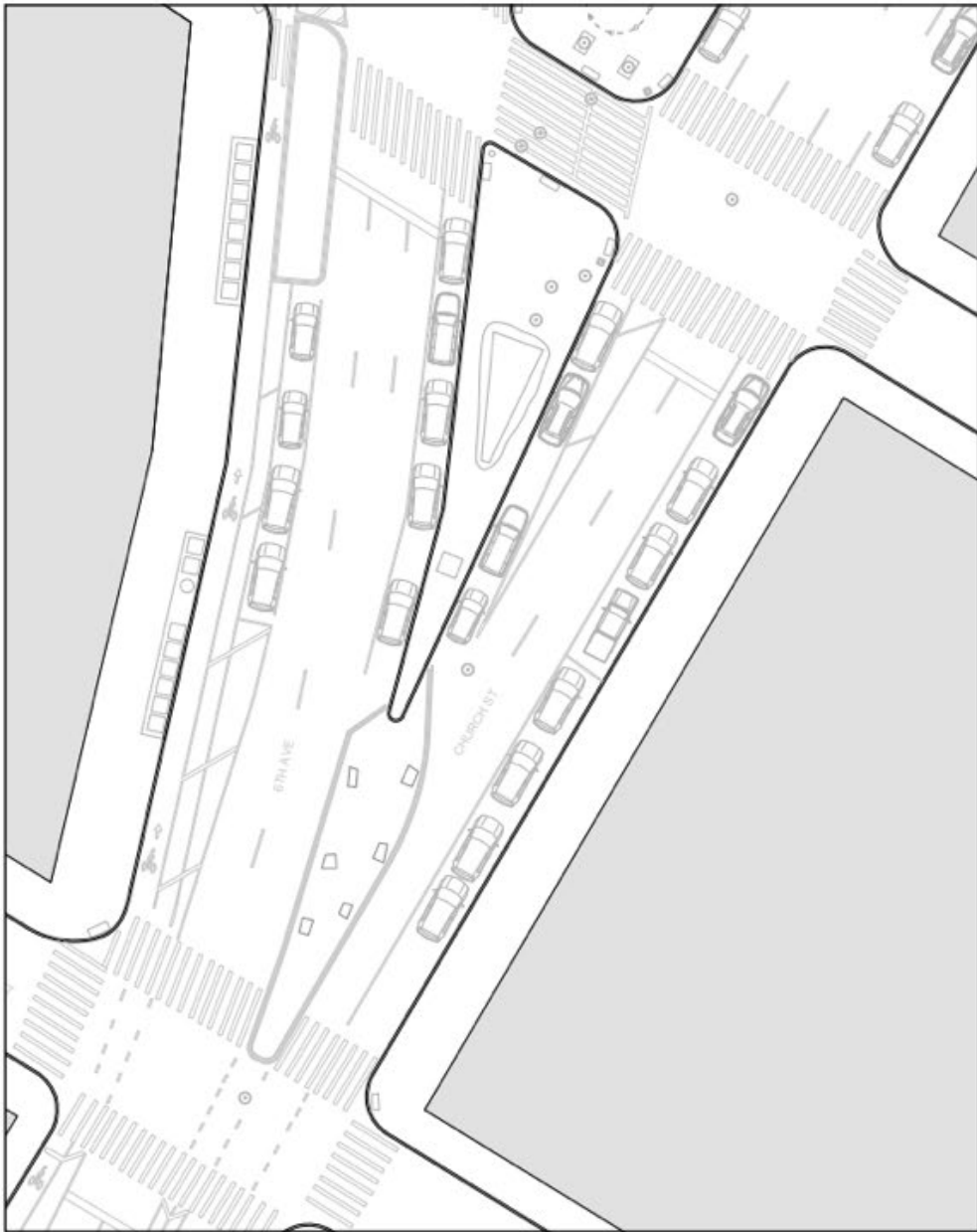

*Current Conditions*

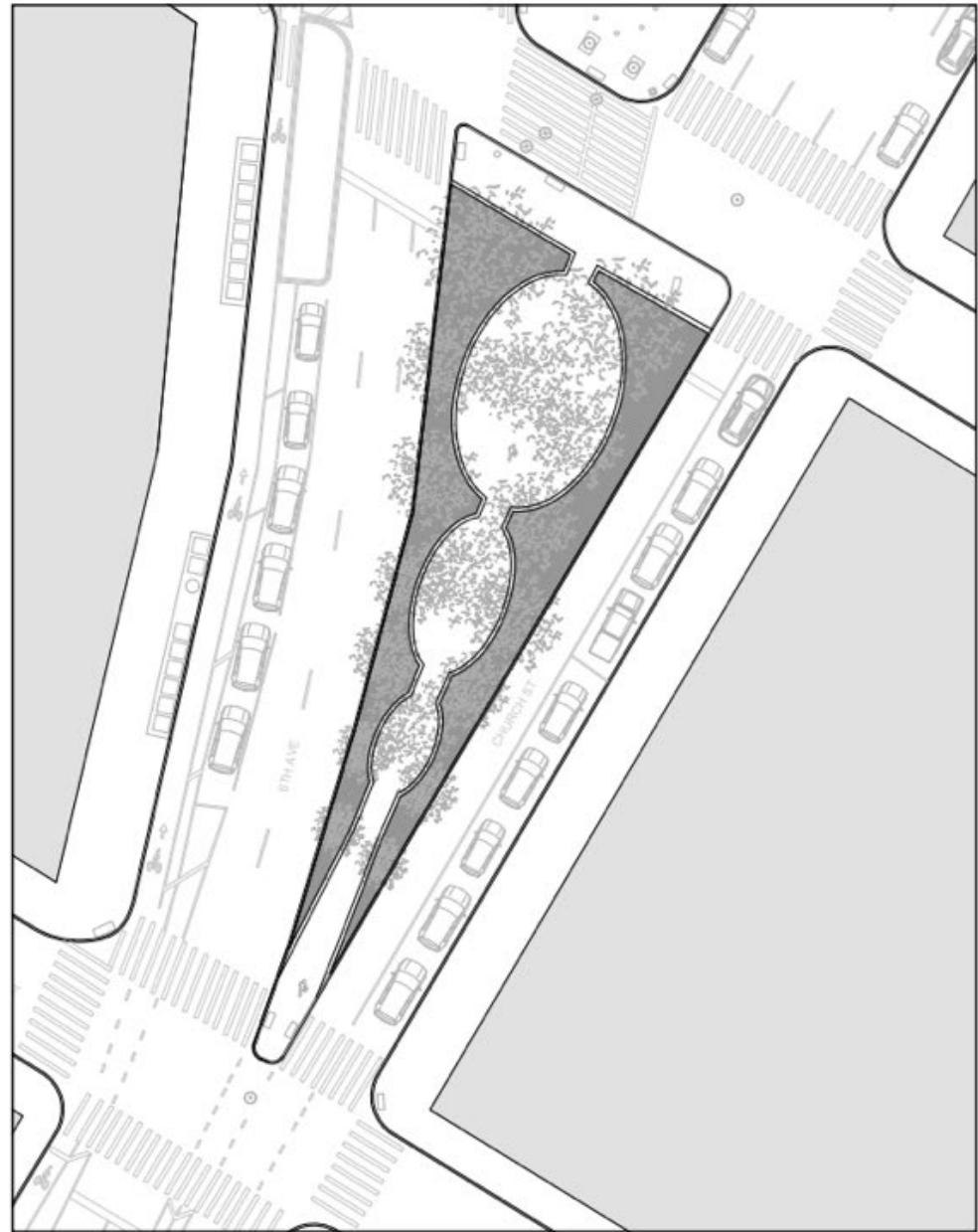

*Design Proposal*

# MANHATTAN COMMUNITY BOARD 1

## Transportation & Street Permits Committee - B. Kay

### 1. Request for MTA bus route on Rt 9A between W.14th St and Chambers St. (in support of CB2 resolution) – Report



# MANHATTAN COMMUNITY BOARD 1

## Quality of Life, Health, Housing & Human Services Committee - P. Moore

### 1. Borough Based Jail Project Updates from DDC - Report

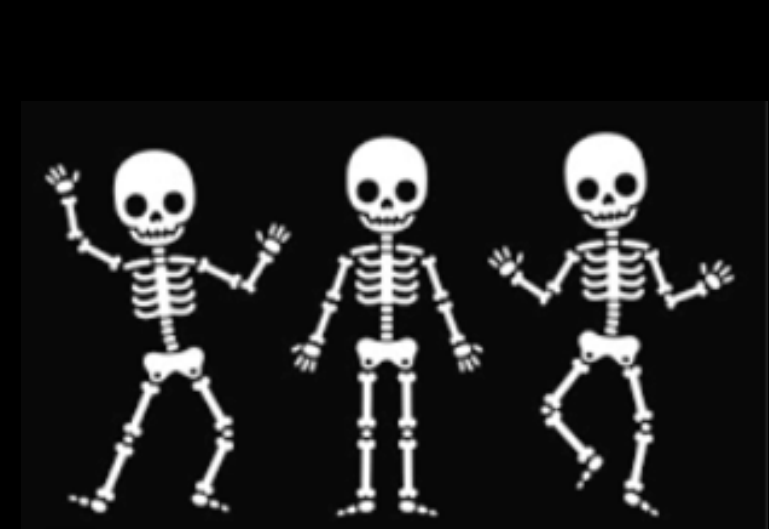

# MANHATTAN COMMUNITY BOARD 1

---

## Environmental Protection Committee - A. Blank

1. Lead Paint Right to Know Act legislation -  
Resolution

2. Update on Seaport Coastal Resiliency Plans -  
Report





# Project Overview | Lower Manhattan Coastal Resilience (LMCR)



# Project Overview | What is Seaport Coastal Resilience?

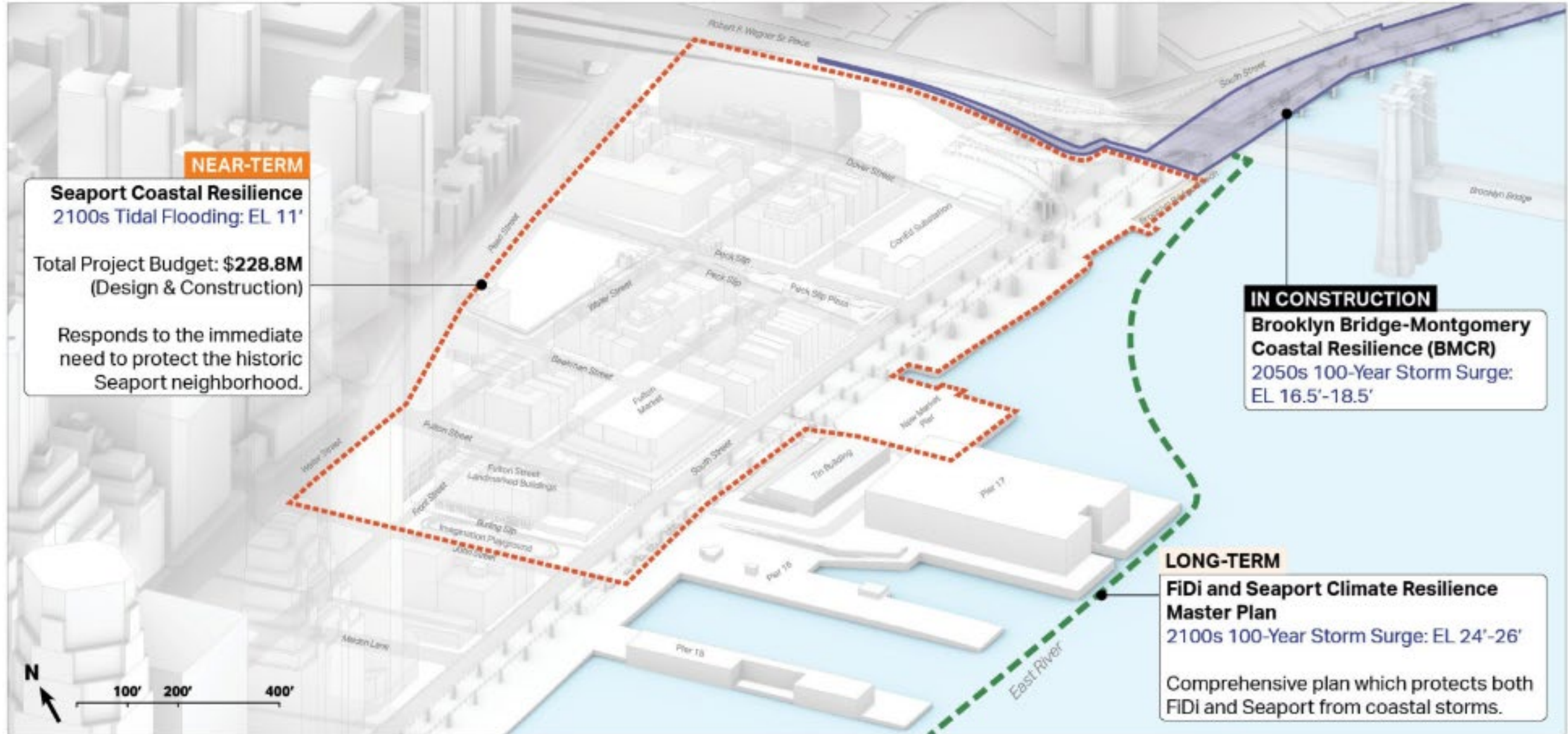



# Project Overview

## Purpose and Need

- Protect the Seaport neighborhood from projected Sea Level Rise in 2100
- Achieve a Design Flood Elevation of 11 ft (NAVD88)
- Mitigate impacts from extreme precipitation and the urban heat island effect
- Project is necessary to protect the Seaport from environmental hazards that would cause major disruptions and ultimately render the area unusable

## Additional Goals and Objectives

- Use innovative design and engineering strategies to integrate flood protection into a public esplanade and historic district
- Improve access to and along the waterfront
- Avoid or minimize impacts to existing infrastructure





# Flood Alignment Update | Two Project Zones

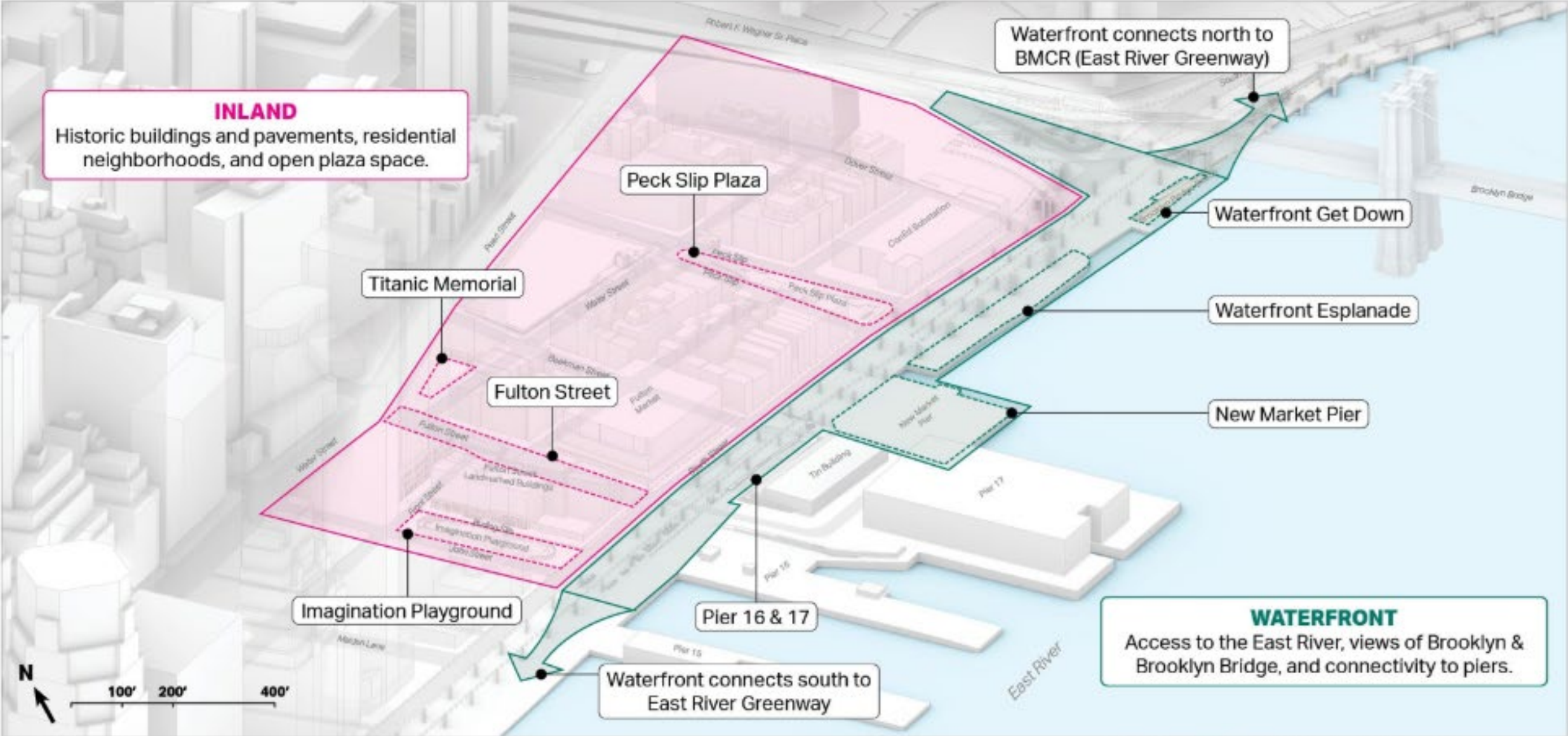

# Flood Alignment Update | Flood Alignments Considered

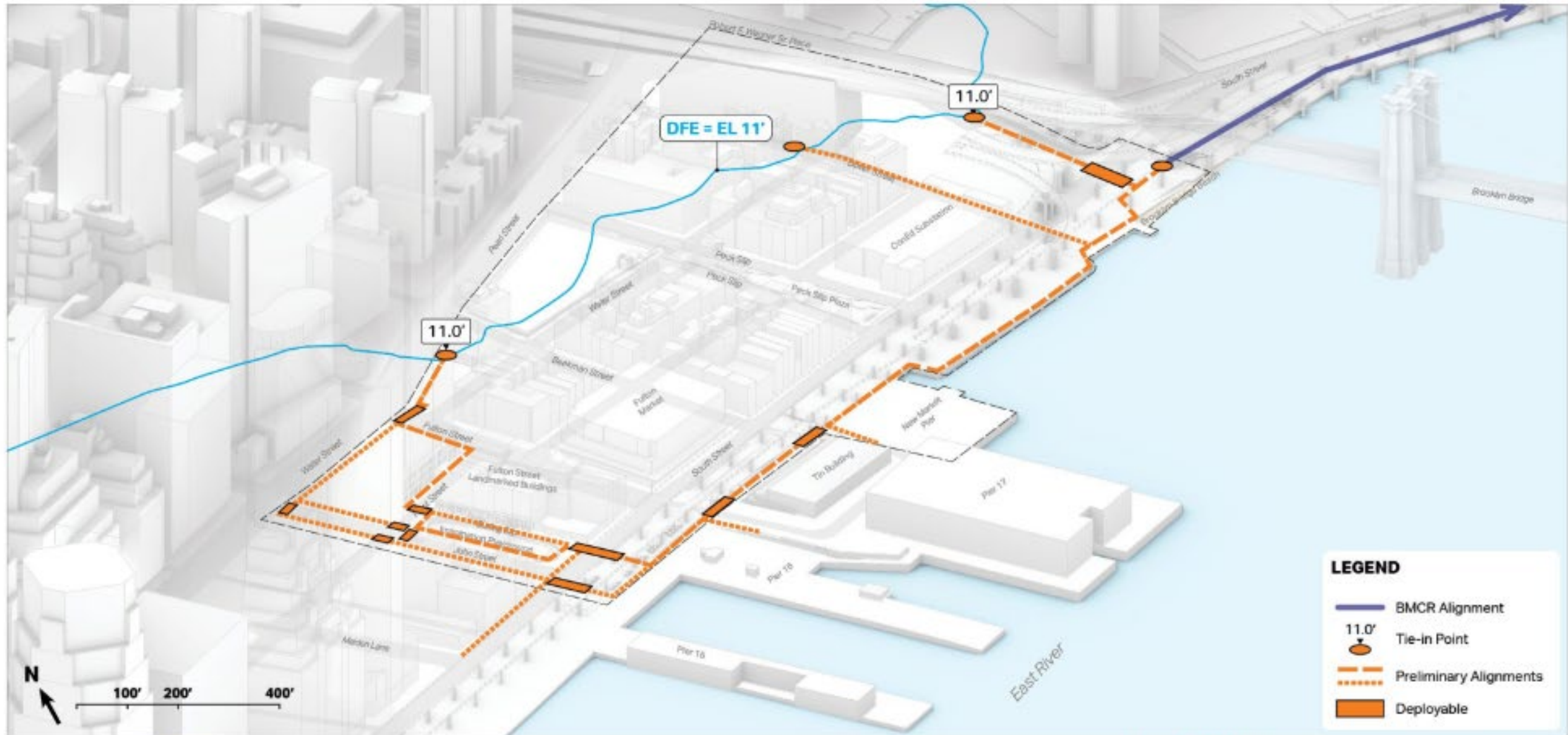



# Flood Alignment Update | Height of Intervention

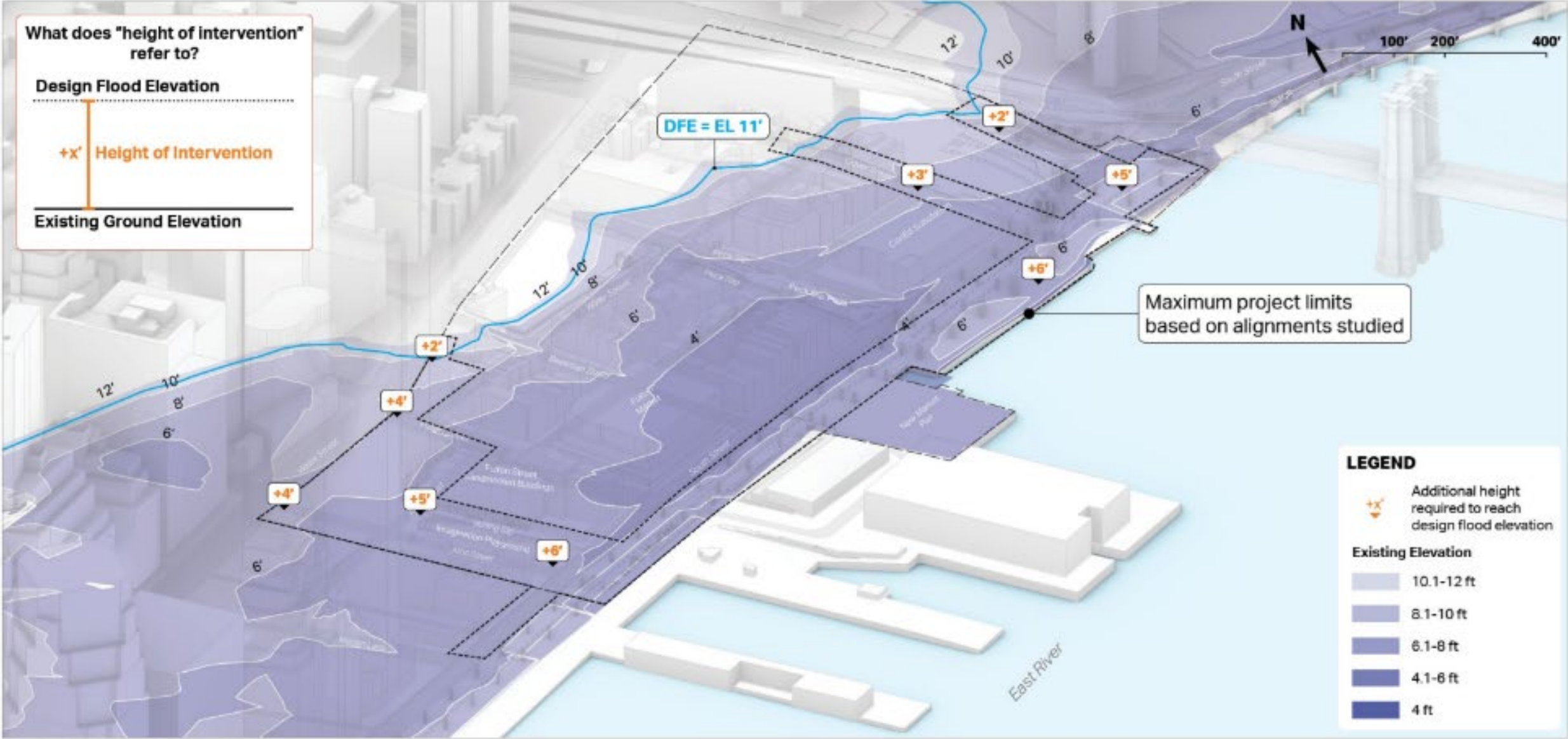



# Flood Alignment Update | Placemaking Design Toolkit

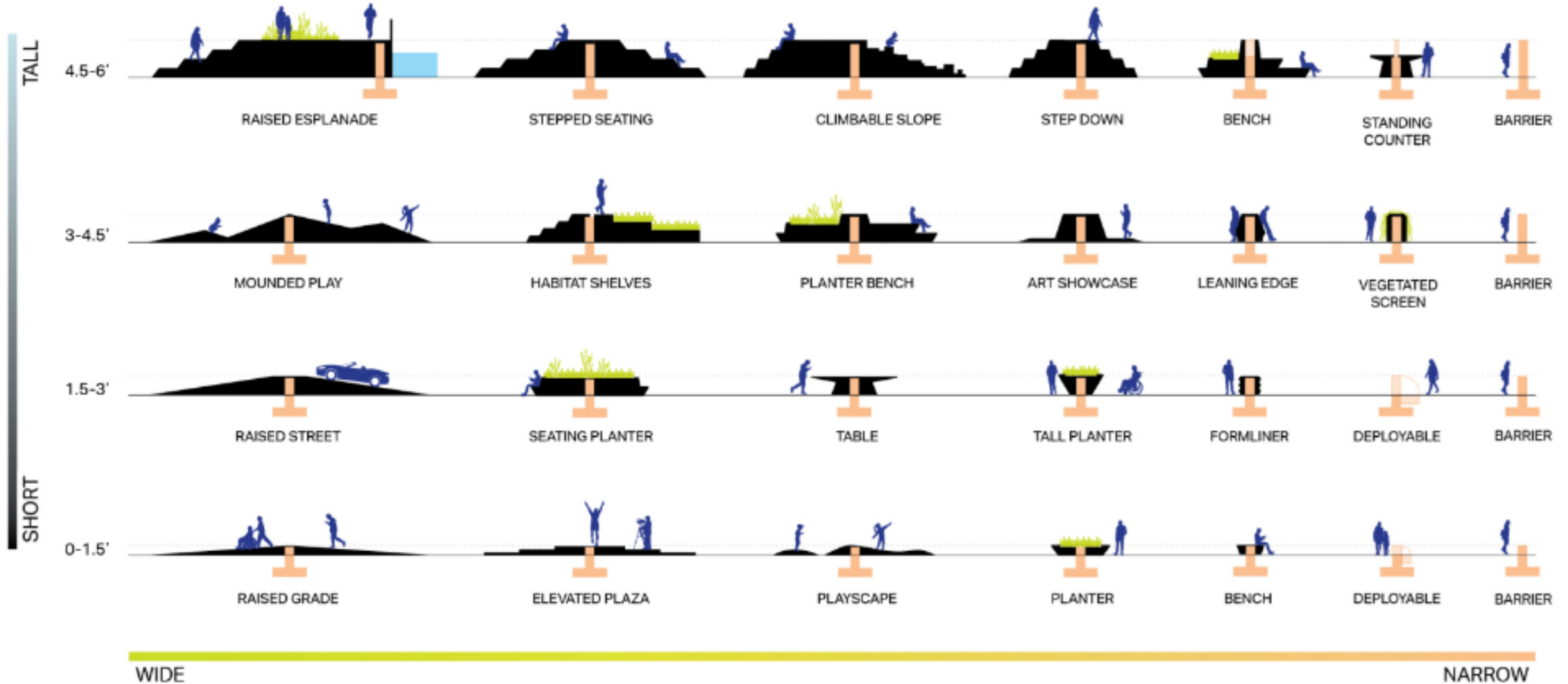

# Flood Alignment Update | Design Flood Alignment

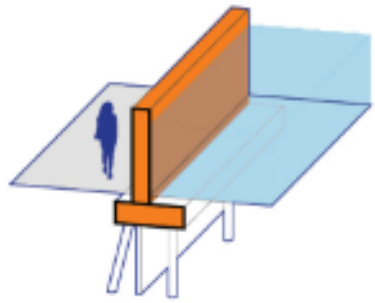

Flood Barrier

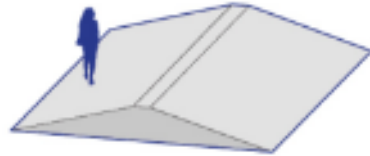

Raised Grade

**PASSIVE**

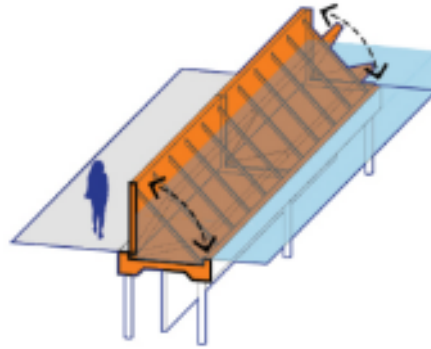

Flip-Up Gate

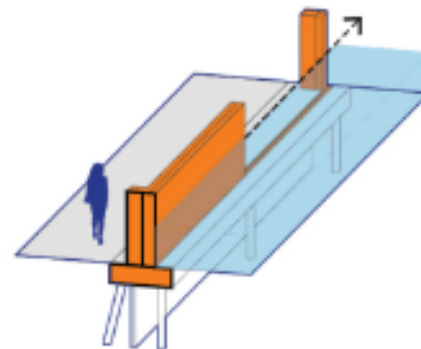

Roller Gate

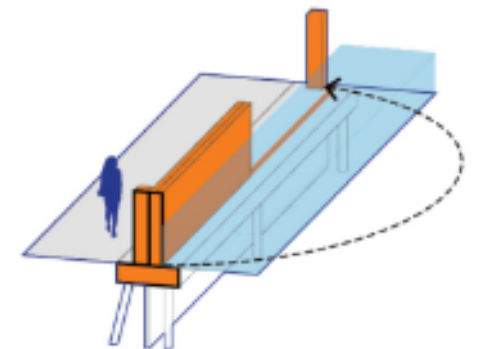

Swing Gate

**DEPLOYABLE**

# Next Steps | Community Outreach

**November** Factsheet/ Newsletter: Project facts and updates in preparation for Community Meeting #2

**November** LMCR Quarterly Update

**December** Community Meeting #2: Alignment Updates & Public Realm Design Workshop

**December/ January** Community Board 1 (Environmental Protection Committee): Share feedback from Community Workshop and design progress

**Spring 2025** Walking Tours/ Pop Up Events

**Spring 2025** Community Meeting #3: Present design progress and receive feedback





# MANHATTAN COMMUNITY BOARD 1

## Landmarks & Preservation Committee - J. Friedman

1. Proposed installation of mobile telecommunications equipment on a streetlight pole located at William Street between Beekman Street and Ann Street (OTI #12713) - Resolution





LinkNYC



Link5G



4G Poletop Installation (Existing Light Pole)



5G Poletop Installation (Existing Light Pole)



# MANHATTAN COMMUNITY BOARD 1

## Battery Park City Committee - J. Galloway

1. BPC Security Update – Report
2. Programming, Construction and Event Updates – Report





# MANHATTAN COMMUNITY BOARD 1

## Licensing & Permits Committee - S. Cole

### Tribeca area

1. 157 Duane Street, ground floor, a new application for Jupira Lee dba Boteco do Casa for full liquor license – Resolution
2. 76 Chambers Street, new application for Au Passage LLC dba Freddy's for wine, beer & cider license – Resolution

### Battery Park City area

End Ave, new application for BP OPCO LLC dba Battery Park City for wine, beer & cider license – Resolution



# MANHATTAN COMMUNITY BOARD 1

## Licensing & Permits Committee - S. Cole



### Financial District area

1. 40 Broad Street, 2nd floor, new application for 40 Restaurant LLC & Reserved Hospitality Group LLC dba Reserve Cut for full liquor license – Report
2. 18 William Street, method of operation change to extend hours of operation, Submursive LLC, Hanover Hospitality LLC & 18 William PTR dba Submursive for full liquor license – Resolution
3. 5 Gold Street, application for a corporate change for Flames Steakhouse Inc. dba Giardino D'Oro for full liquor license – Resolution
4. 130 William Street, new application and temporary retail permit for CH 130 Corp DBA Remi Flower & Coffee for wine, beer & cider license – Resolution
5. 185 Greenwich Street, new application and temporary retail permit for Legends Hospitality Inc for wine, beer & cider license – Resolution

# MANHATTAN COMMUNITY BOARD 1

## Old Business





# MANHATTAN COMMUNITY BOARD 1

## New Business



# MANHATTAN COMMUNITY BOARD 1

## Adjournment



# MANHATTAN COMMUNITY BOARD 1

---

**All documents relating to the above agenda items are on file at the Community Board 1 office and are available for viewing by the public upon written request to [man01@cb.nyc.gov](mailto:man01@cb.nyc.gov)**

**At all meetings, additional items may be raised as "New Business"**