

FORENSIC BIOLOGY PROTOCOLS FOR FORENSIC STR ANALYSIS

PowerPlex Fusion - Capillary Electrophoresis		
Status: Published		Document ID: 5981
DATE EFFECTIVE 12/17/2021	APPROVED BY Nuclear DNA Technical Leader	PAGE 1 OF 18

PowerPlex Fusion– Capillary Electrophoresis on 3500xL

1 Setting Up 3500xL Run

Important Reminder – At any time during set-up or if a plate is currently running, DO NOT open instrument doors if the autosampler is in motion.

NOTE: Steps 1.1-1.5 should only be performed if instrument has been turned off.

- 1.1 Power on the computer attached to the instrument. Do not log in.
- 1.2 Power on the instrument and wait for green front panel indicator to stop blinking.
- 1.3 Log in to computer.
- 1.4 Look for a pop-up at the bottom right of the desktop.



- 1.5 Wait for ~1-2 minutes for the Server Monitor icon to change from red X to green check mark.

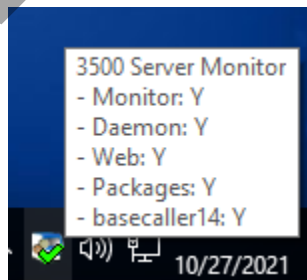

NOTE: If the Server Monitor icon does not change to a green checkmark, you cannot start the software. See Section 6: Troubleshooting. Contact QA for assistance if issues arise.

- 1.6 Open the 3500xL Data Collection v4 software by double clicking on the desktop Icon  or select **Start > AppliedBiosystems > 3500 > 3500 icon**

FORENSIC BIOLOGY PROTOCOLS FOR FORENSIC STR ANALYSIS

PowerPlex Fusion - Capillary Electrophoresis		Document ID: 5981
Status: Published		
DATE EFFECTIVE 12/17/2021	APPROVED BY Nuclear DNA Technical Leader	PAGE 2 OF 18

Figure 1: Dashboard

A. Navigation Tabs – change between **Dashboard**, **Workflow**, and **Maintenance** views

B. Create New Plate – used to name and import plate information onto instrument

C. Wizards – contains wizards for changing POP4 and removing bubbles

D. Gauges – quick view of consumables and number of injections run on instrument

E. Start Pre-Heat – button to start oven pre-heating

F. Consumables Information Table – shows time consumables have been on the instrument

Consumable	Name	Status	Days on Instrument	Expiration Date	Lot Number	Part Number
Pouch	POP4	331 Samples Remaining	7 Days 2.6 Hrs	09-Jan-2021 11...	2001200	4023715
Anode Buffer	ABC	6 Days 21.7 Hrs Remaining	7 Days 2.3 Hrs	21-Dec-2020 11...	2003603	4393027
Cathode Buffer	CBC	6 Days 21.7 Hrs Remaining	7 Days 2.3 Hrs	02-Feb-2021 11...	2005664	4400396
Capillary Array	36cm - 24 cap	145 Injections Remaining	153 Days 7.4 Hrs	09-Feb-2021 11...	11	4403687 - Serial # M320A1117

- 1.7 Click **Refresh** (on the right above the **Consumables Information** table) to update the consumables information and check the status of the consumables in the **Dashboard**.
- 1.8 Check the consumables. NOTE: QA team will routinely perform maintenance on the instruments and replace the consumables once they reach near expiration date. Notify QA if any issues arise. If consumables need to be replaced with no other maintenance needed, then a casework analyst may change the expired consumables and log this in LIMS.
 - 1.8.1 POP4 Polymer –
 - 1.8.1.1 Check the number of samples remaining and number of injections remaining. To ensure that the POP4 can accommodate your plate/samples, use the lower value.

FORENSIC BIOLOGY PROTOCOLS FOR FORENSIC STR ANALYSIS

PowerPlex Fusion - Capillary Electrophoresis		
Status: Published		Document ID: 5981
DATE EFFECTIVE 12/17/2021	APPROVED BY Nuclear DNA Technical Leader	PAGE 3 OF 18

- For example, if the **Dashboard** shows 48 samples remaining and 10 injections remaining, the lower value would be 48 samples as that equates to 2 full injections, which is less than 10 injections. The number of injections remaining is more likely to be affected by multiple partial plates; i.e. the number of injections will lower at a faster rate than the number of samples remaining.
- 1.8.1.2 Check the Consumables Information Table (Fig1 F) under the “Days on Instrument” column to ensure that the POP4 is ≤ 14 days old. The instrument will countdown how long, to the hour and minute, the consumables will be usable.
- 1.8.1.2.1 One injection takes approximately 40 minutes. For example, 2 injections will take approximately 1 hour and 20 minutes. For a 2 injection run, all consumables must then have more than 1 hour 20 minutes remaining before starting the run.
- 1.8.1.3 If the POP4 needs to be changed, remove a polymer pouch from fridge and allow it to equilibrate to room temperature before use (~30 mins). Ensure there are no crystals before installing on the instrument. Click on the **Wizards** button (Fig1 C) and follow the **Replenish POP4** Wizard.
- 1.8.1.3.1 Each time the lever to fix the POP4 in place has been lowered, the bubble removal wizard should be performed, as the action may have introduced bubbles.
- 1.8.2 Anode Buffer Container (ABC) –
- 1.8.2.1 Check the time remaining and injections remaining to ensure that the days and hours are >0 and the consumables remaining can accommodate both your plate injections and run time (refer to step 1.8.1.2.1).
- 1.8.2.2 If the ABC needs to be changed, follow directions in Section 5.
- 1.8.3 Cathode Buffer Container (CBC) –
- 1.8.3.1 Check the time remaining and injections remaining to ensure that the days and hours are >0 and the consumables remaining can accommodate both your plate injections and run time (refer to step 1.8.1.2.1).
- 1.8.3.2 If the CBC needs to be changed, follow directions in Section 5.
- 1.8.4 Capillary Array –
- 1.8.4.1 Proceed only if the total number of injections that has been run on the instrument plus the intended number of injections to be performed is ≤ 160 . Notify QA if capillary injection number reaches close to 160 and needs to be replaced.

FORENSIC BIOLOGY PROTOCOLS FOR FORENSIC STR ANALYSIS

PowerPlex Fusion - Capillary Electrophoresis		
Status: Published		Document ID: 5981
DATE EFFECTIVE 12/17/2021	APPROVED BY Nuclear DNA Technical Leader	PAGE 4 OF 18

- 1.8.4.2 Check the number of injections on the capillary in the 3500xL usage log and on the **Dashboard**, if the numbers are not the same, update the usage log.

2 Procedure

- 2.1 Retrieve amplified samples from the thermal cycler or refrigerator.
- 2.2 Prepare thermal cyclers for snap/de-chill step.
- 2.2.1 Set one thermal cycler to 95°C (heat program) and another thermal cycler to 4°C (chill program).
- 2.2.1.1 Thermal cyclers should be turned off after each use.
- 2.3 Turn on the oven by clicking **Start Pre-Heat** on the 3500xL **Dashboard**, and make sure that the temperature is set to 60°C. Pre-Heating the oven is recommended at least **30 minutes** before the run is started. The pre-heat button can be pressed right before a run; however, the instrument will not begin until the temperature has reached 60°C.
- 2.4 Spin down samples at 1000 RPM for one minute.
- 2.5 Retrieve the following reagents from the associated refrigerator and/or freezer for relevant system. NOTE: HiDi Formamide must **NOT** be re-frozen.

Fusion 5C
PowerPlex Fusion® WEN ILS 500
PowerPlex Fusion® Allelic Ladder
HiDi Formamide

- 2.6 Prepare dilutions of amplified samples, if necessary. 0.1X TE⁻⁴ should be used to make the dilutions. Pipette mix prior to aliquoting for dilution. Ensure that TE⁻⁴ lot number is recorded.
- 2.6.1 When manually recording lot numbers, include the entire series of letters and numbers (i.e., 0.1XTE1612155668) in the Notes section of the test batch.
- 2.7 Record lot numbers of reagents in LIMS.
- 2.7.1 The cathode buffer lot number must be recorded in LIMS for all 3500 xL batches even if the analyst has not personally replaced it. If the buffer has been replaced by QA during maintenance, transfer the cathode buffer lot information from either the maintenance log in LIMS or on the QA label on the cathode buffer reservoir on the instrument.
- 2.7.2 The anode buffer and POP lot numbers are listed in LIMS as part of the instrument maintenance/usage log. Ensure the anode lot number matches with the one listed in the

FORENSIC BIOLOGY PROTOCOLS FOR FORENSIC STR ANALYSIS

PowerPlex Fusion - Capillary Electrophoresis		
Status: Published		Document ID: 5981
DATE EFFECTIVE 12/17/2021	APPROVED BY Nuclear DNA Technical Leader	PAGE 5 OF 18

maintenance/usage log by looking at the LIMS labels on the anode buffer reservoir on the instrument. If the anode buffer was changed, update this accordingly in LIMS.

- 2.8 Prepare master mix for all samples, negative and positive controls, and allelic ladders as specified below: (9.5 µL of HiDi + 0.5 µL of size standard per sample)

Fusion 5C		
# Samples (+ 2)	HiDi	ILS500
24	247 uL	13 uL
48	475 uL	25 uL
72	703 uL	37 uL
96	931 uL	49 uL

- 2.9 Vortex the ILS/formamide master mix for 10-15 seconds to mix.
- 2.10 Obtain a reaction plate and label the side with the plate name - based on the instrument, date, and injection number(s) (i.e. Carmody121620 25).
- 2.11 Aliquot **10 µL** of **master mix** to each well.
- 2.11.1 If an injection has less than 24 samples, add at least 10 uL of either dH₂O, HiDi, buffer, or master mix to all unused wells within that injection.
- 2.12 **Witness step.** Have another analyst verify the tube setup by comparing the tube labels and positions indicated on the Load Plate Screen in the LIMS system with the tube labels and positions of the amp tubes. The entire amp tube label must be read for each sample.
- 2.12.1 For samples being transferred from a Fusion Direct amplification plate:
- 2.12.1.1 The witness must verify that each individual sample well is in the same order by comparing the amplification test batch Load Plate screen against the STR test batch Load Plate screen. This must be verified by hovering the cursor over the wells and corresponding samples on the plate images, not by using the load plate sample list.
- 2.12.1.2 The analyst must state the test batch ID on the amplification plate and amplification time; the witness must verify this information in the amplification test batch in LIMS.
- 2.12.1.3 Controls - verify that the positive control date and time from the amplification test batch is the same as the positive control date and time in the STR test batch.
- 2.12.1.4 Sample wells - analyst setting up the plate must state which wells hold amplified product and are being transferred from the amplification plate. Analyst must also state the wells being loaded in the STR plate. Witness must verify that the wells are correct in the Load Plate screens of the amplification test batch and the STR test batch.

FORENSIC BIOLOGY PROTOCOLS FOR FORENSIC STR ANALYSIS

PowerPlex Fusion - Capillary Electrophoresis		
Status: Published		Document ID: 5981
DATE EFFECTIVE 12/17/2021	APPROVED BY Nuclear DNA Technical Leader	PAGE 6 OF 18

- 2.13 Aliquot **1 μ L** of allelic ladder, positive/negative control, and sample into their appropriate wells.
- 2.13.1 Sample order is as follows: A1, B1, C1... A2, B2, C2, etc.
- 2.13.2 Samples may be loaded from a PowerPlex Fusion Direct amplification plate into the CE plate by using a multichannel pipette. **1 μ L of allelic ladder must be loaded separately into the appropriate wells.**
- 2.14 Once all samples have been added to the plate, place a new 96-well septa over the reaction plate and firmly press the septa into place.
- 2.15 Spin the plate in the centrifuge at 1000 RPM for one minute.
- 2.16 Denature plate for **3 minutes** with the thermal cycler set to 95°C.
- 2.17 Immediately chill plate for **3 minutes** with the thermal cycler set to 4°C.
- 2.18 Spin the plate in the centrifuge at 1000 RPM for one minute again.
- 2.19 While plates are denature/chilling, set up the plates in 3500xL data collection software.
- 2.20 Import the Instrument Plate Record. Use the **Download to Instrument** Button on the Plate Record screen to have LIMS create the plate record. This will be created in the LIMS file share drive.
- 2.20.1 Copy the LIMS plate record from the LIMS file share to the Plate Records folder on the instrument computer.
- 2.21 Click **Create New Plate** button on the **Dashboard** and ensure the following screen is visible:

The screenshot displays the 'Plate Details' configuration window in the Applied Biosystems software. The window title is 'Plate Details'. The 'Name' field contains 'Carmody121620 25'. The 'Number of Wells' section has three radio buttons: '96' (selected), '96-Fast', and '384'. The 'Plate Type' is a dropdown menu set to 'HID'. The 'Capillary Length' is a dropdown menu set to '36' with 'cm' as the unit. The 'Polymer' is a dropdown menu set to 'POP4'. At the top of the window, there are buttons for 'New Plate', 'Open Plate', 'Save Plate', 'Close Plate', and 'Start Run'. On the left side of the software interface, there is a sidebar with 'Advanced Setup' and 'Run Instrument' sections.

- 2.21.1 Name your plate using the naming system based on the instrument, date, and injection number(s) (i.e. Carmody121620 25).

Controlled versions of Department of Forensic Biology Manuals only exist in the Forensic Biology Qualtrax software. All printed versions are non-controlled copies.

FORENSIC BIOLOGY PROTOCOLS FOR FORENSIC STR ANALYSIS

PowerPlex Fusion - Capillary Electrophoresis		
Status: Published		Document ID: 5981
DATE EFFECTIVE 12/17/2021	APPROVED BY Nuclear DNA Technical Leader	PAGE 7 OF 18

2.21.2 Ensure the settings match the following:

- Number of Wells: **96**
- Plate Type: **HID**
- Capillary Length: **36cm**
- Polymer: **POP4**

2.21.3 Click **Assign Plate Contents** at the bottom of the screen

2.21.4 Click on the **Import** button at the top of the screen to import your plate record file.

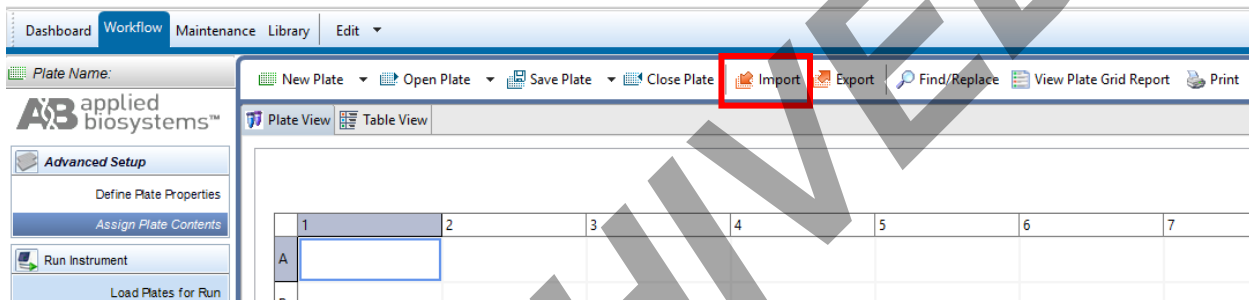

2.21.5 Ensure that all 3 settings at the bottom of the screen (Assay, File Name Convention, and Results Group) have check marks and have the correct settings from the library, and check that all used wells are the correct samples and are highlighted as shown below.

2.21.5.1 Clicking the square in upper left corner in plate view will **highlight** the entire plate. If plate view appears compressed, click **Fit** on upper right corner.

Settings	Fusion
Assay	Fusion5C
File Name Convention	OCME Casework
Results Group	OCME Casework

FORENSIC BIOLOGY PROTOCOLS FOR FORENSIC STR ANALYSIS

PowerPlex Fusion - Capillary Electrophoresis

Status: Published

Document ID: 5981

DATE EFFECTIVE
12/17/2021

APPROVED BY
Nuclear DNA Technical Leader

PAGE
8 OF 18

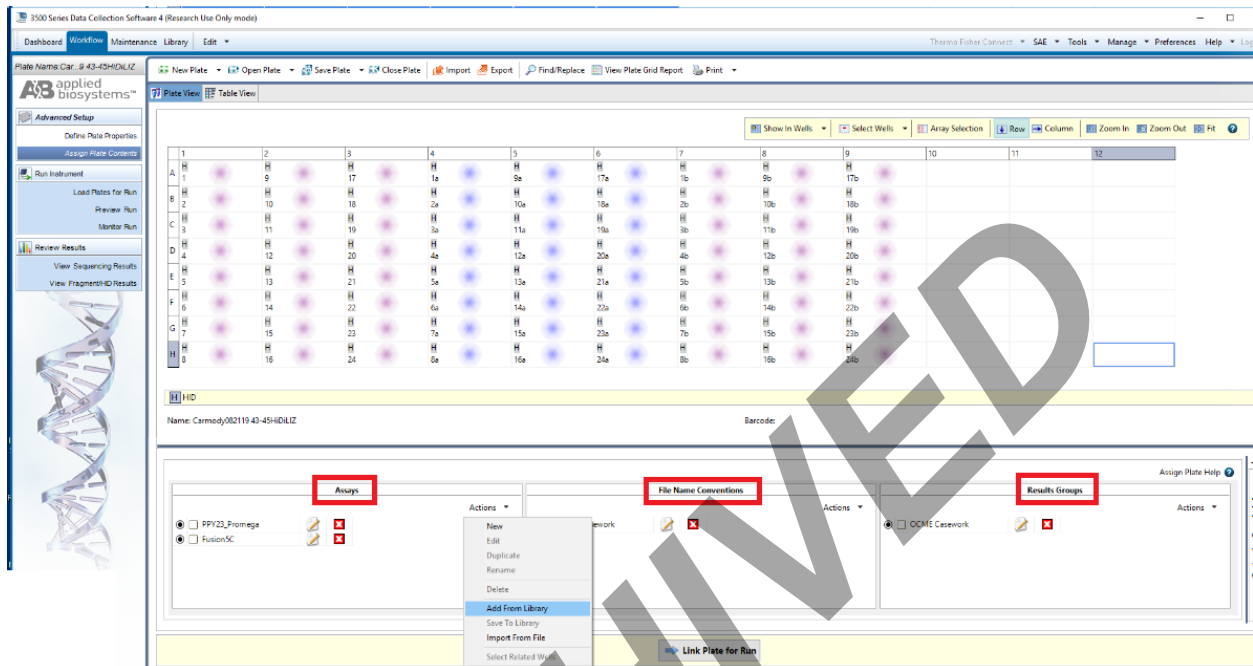

- 2.22 Check the Plate View to ensure the correct number of samples and injections are being run.
- 2.23 Different assays can run together on a single plate as long as they are in different injections. For example, injection one (first 24 wells) can be assigned the Fusion assay and injection two can be assigned to the Yfiler assay.
 - 2.23.1 If any of the library settings are missing, select actions dropdown/Add from Library to add necessary settings.
- 2.24 Load plate on instrument.
 - 2.24.1 Push the tray button on the bottom left of the machine and wait for the autosampler to move forward and stop at the forward position before opening the door.
 - 2.24.2 Open the door and place the tray onto the autosampler in the correct tray position, A or B. There is only one orientation for the plate. (The barcode on the plate base and retainer should be facing outwards, towards the user.)
 - NOTE: Push and open the clip on the side of the autosampler, place plate on instrument and release clip so that the plate is secure.

Controlled versions of Department of Forensic Biology Manuals only exist in the Forensic Biology Qualtrax software. All printed versions are non-controlled copies.

© NYC OFFICE OF CHIEF MEDICAL EXAMINER

Qualtrax template 040621

FORENSIC BIOLOGY PROTOCOLS FOR FORENSIC STR ANALYSIS

PowerPlex Fusion - Capillary Electrophoresis

Status: Published

Document ID: 5981

DATE EFFECTIVE
12/17/2021

APPROVED BY
Nuclear DNA Technical Leader

PAGE
9 OF 18

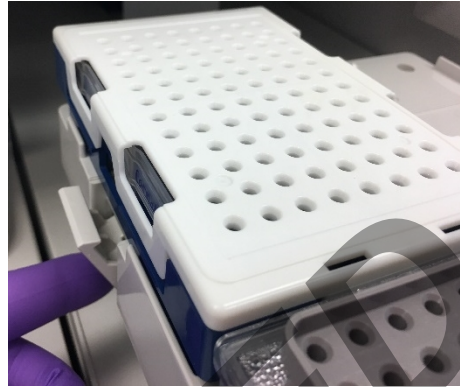
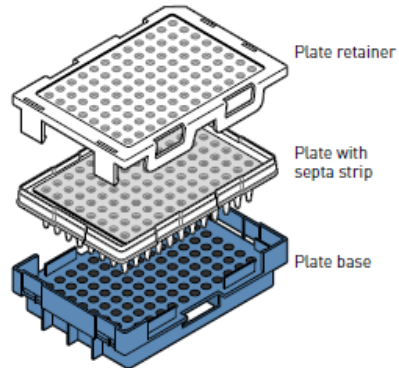

- 2.24.3 Ensure the plate assembly fits flat in the autosampler.
- 2.24.4 Close the instrument door and allow the autosampler to move back to the home position. It takes approximately 10 seconds for the instrument to initialize after the instrument door is closed.
- 2.24.5 Wait for the green light on the front panel before linking the plate.

2.25 Link plate to instrument.

- 2.25.1 Click on  at the bottom of the screen. If you see the following pop-up messages → Click Yes/OK/Link and ensure correct plate is on the autosampler.

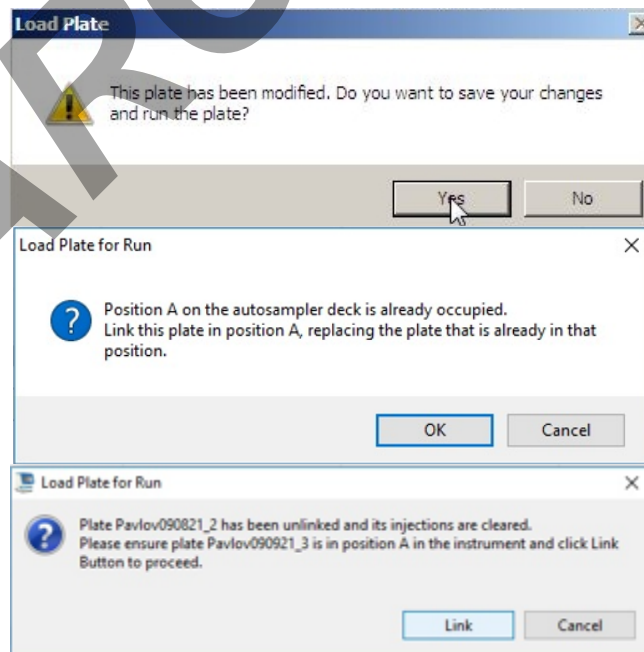

Controlled versions of Department of Forensic Biology Manuals only exist in the Forensic Biology Qualtrax software. All printed versions are non-controlled copies.

© NYC OFFICE OF CHIEF MEDICAL EXAMINER

Qualtrax template 040621

FORENSIC BIOLOGY PROTOCOLS FOR FORENSIC STR ANALYSIS

<h2>PowerPlex Fusion - Capillary Electrophoresis</h2>		Document ID: 5981
Status: Published		
DATE EFFECTIVE 12/17/2021	APPROVED BY Nuclear DNA Technical Leader	PAGE 10 OF 18

2.25.2 The following screen should then appear:

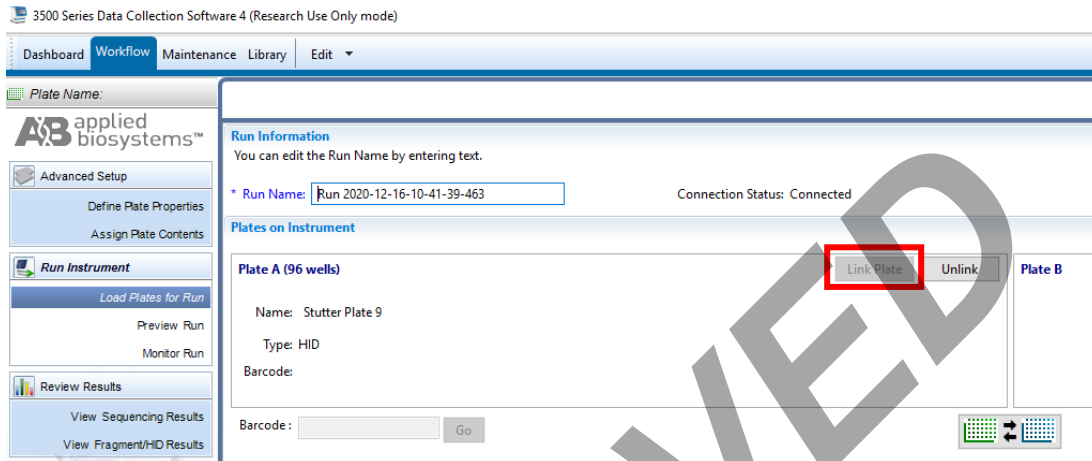

2.26 If two plates are to be loaded, navigate back to **Define Plate Properties** from the left tabs after setting up plate A to create and setup the second plate.

2.26.1 Repeat steps 2.20 to 2.24 for plate B.

2.26.2 Upon linking plate B, the following message will show up. Select **Link this plate in position B**.

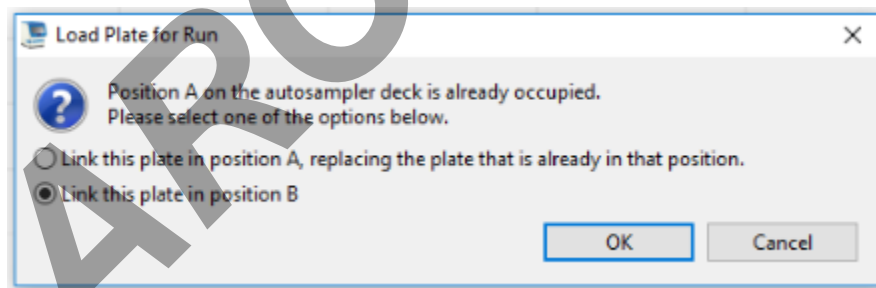

2.26.3 The following screen should appear:

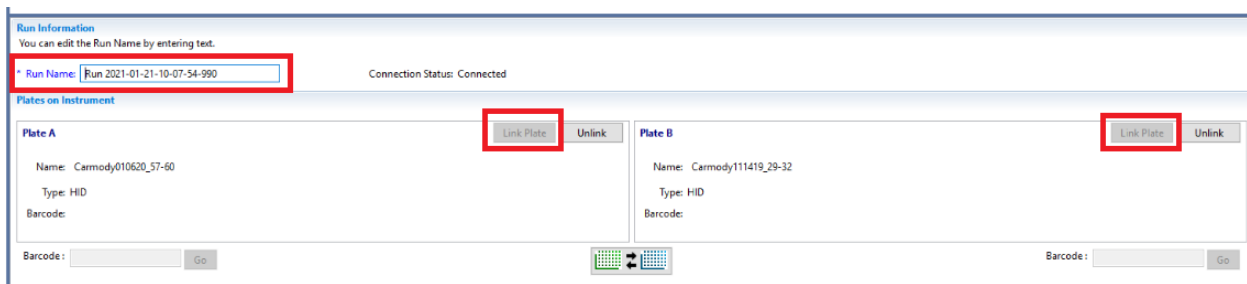

Controlled versions of Department of Forensic Biology Manuals only exist in the Forensic Biology Qualtrax software. All printed versions are non-controlled copies.

© NYC OFFICE OF CHIEF MEDICAL EXAMINER

Qualtrax template 040621

FORENSIC BIOLOGY PROTOCOLS FOR FORENSIC STR ANALYSIS

PowerPlex Fusion - Capillary Electrophoresis		Document ID: 5981
Status: Published		
DATE EFFECTIVE 12/17/2021	APPROVED BY Nuclear DNA Technical Leader	PAGE 11 OF 18

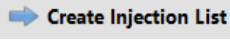
- 2.27 Change the Run Name to reflect all names of the plates that are linked to the instrument.
- 2.27.1 If only a single plate is being run, fill in the run name as is - i.e. Carmody121620 25.
- 2.27.2 If two plates are being run, separate the injection numbers by an underscore - i.e. Carmody121620 25_26-27.
- 2.28 If the **Link Plate** button associated with your plate(s) is not clicked, click it now.
- 2.28.1 Both plates **must** be linked prior to starting the run.
- 2.29 Click on  **Create Injection List** at the bottom of the screen. The following screen will appear.

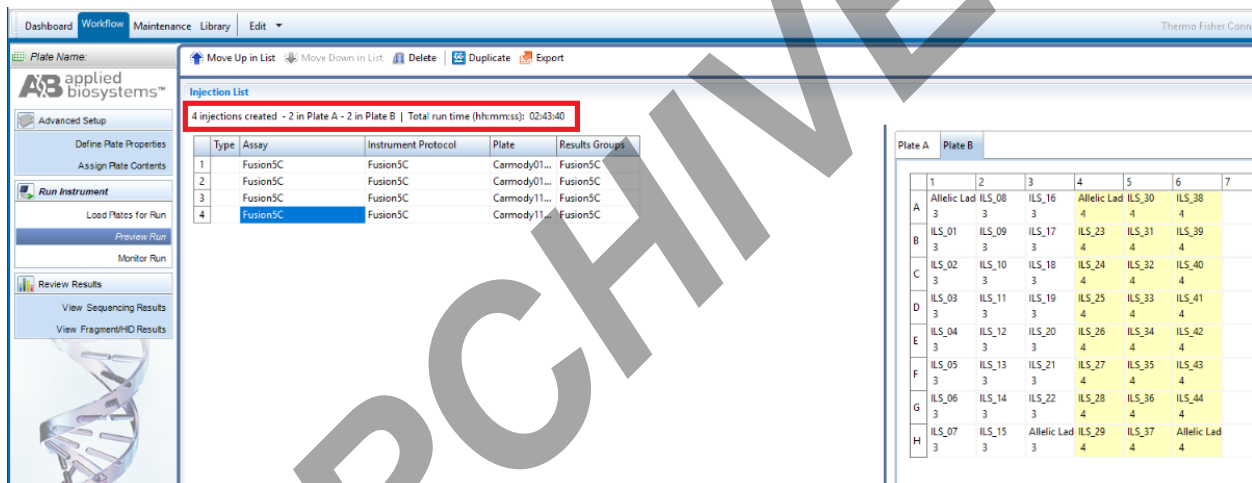

The screenshot shows the 'Injection List' screen in the Applied Biosystems software. At the top, it indicates '4 injections created - 2 in Plate A - 2 in Plate B | Total run time (hh:mm:ss): 02:43:40'. Below this is a table with columns: Type, Assay, Instrument Protocol, Plate, and Results Groups. The table lists four injections, all of type 'Fusion5C' using 'Fusion5C' instrument protocols on plates 'Carmody01...' and 'Carmody11...'. To the right of the table is a plate layout grid for Plate A and Plate B, with wells 1-7. The grid shows 'Allelic Lad' in wells 1, 3, 5, and 7 of both plates, and 'ILS' samples in wells 2, 4, and 6. Well 4 of Plate A is highlighted in yellow.

- 2.30 The injection list screen shows total number of injections created, number of injections per plate, and the total estimated run time.
- 2.30.1 One injection takes approximately ~ 40 minutes
- 2.31 Ensure correct library settings (left side) are selected for each injection created (right side).
- 2.31.1 Clicking each injection will highlight the corresponding wells on the plate.
- 2.32 Ensure the instrument is ready to go by checking reservoirs are filled properly, plate is linked correctly, and no bubbles are present in the polymer block.
- 2.32.1 If bubbles are present, click on **Wizards** → **Remove Bubbles Wizard**
- 2.33 The run will not start until all indicators shown in the dashboard are green.

FORENSIC BIOLOGY PROTOCOLS FOR FORENSIC STR ANALYSIS

PowerPlex Fusion - Capillary Electrophoresis		
Status: Published		Document ID: 5981
DATE EFFECTIVE 12/17/2021	APPROVED BY Nuclear DNA Technical Leader	PAGE 12 OF 18

- 2.33.1 Navigate back to dashboard by clicking **Dashboard** on top of the screen to ensure all indicators are green



- 2.33.2 Return to the injection list by clicking **Workflow** on top of the screen and then **Preview Run** on the left side of the screen.

- 2.34 Click on **Start Run** at the bottom center of the screen.

- 2.35 Enter a LIMS usage log for current run, recording lot numbers of buffer and POP4 in the usage log if they were changed for the run.

- 2.36 Amplification tubes will be stored in the fridge at approximately 4°C-8°C, filed by instrument and run name. Fusion Direct amplification plates should be discarded.

- 2.36.1 Amplification tubes should be stored with their most recent 3500 run. For example, a sample initially run on Carmody is rerun on Avogadro. That tube should now be stored with the samples on the Avogadro run. Do not return the tube to its initial run storage box.

- 2.36.2 If a positive control is being pulled for use from a previous run, the tube should be returned to its original run box after use to remain associated with its original amp set.

- 2.37 The following are the instrument parameters for each assay:

	Fusion
Oven Temp	60°C
Pre-Run Voltage	15.0 kV
Pre-Run Time	180 sec
Injection Voltage	1.2 kV
Injection Time	24 sec
Run Voltage	13 kV
Run Time	1500 sec

3 Collecting Data

- 3.1 When a run is complete, it will automatically be placed in D:/AppliedBio/Current Runs folder and labeled with either the *plate name* (e.g. Carmody102320 12-14) or *run name* (e.g. Carmody102320 12-14_15-16).

FORENSIC BIOLOGY PROTOCOLS FOR FORENSIC STR ANALYSIS

PowerPlex Fusion - Capillary Electrophoresis		
Status: Published		Document ID: 5981
DATE EFFECTIVE 12/17/2021	APPROVED BY Nuclear DNA Technical Leader	PAGE 13 OF 18

- 3.1.1 In these folders, additional inner folders with the HID files, separated per run, are labeled with *plate name* and *date/time* (e.g. Pavlov090921_3-2021-09-09-23-11). Transfer these inner folders to the FBIO network folder.
- 3.1.2 Proceed to Analysis section of the [GeneMarker manual](#).

4 Re-injections

- 4.1 Plates should be re-injected as soon as possible.
 - 4.1.1 Create a new test batch and plate record. See LIMS Manual for [STR Reinjections](#).
 - 4.1.2 Ensure Instrument is set up.
 - 4.1.3 Follow steps in section 2, starting with steps 2.15, re-denature/chill the plate.

5 Changing Buffers

- 5.1 Change buffer on instrument. Buffer only needs to be changed once every 14 days.
 - 5.1.1 Anode Buffer Container (ABC)
 - 5.1.1.1 Remove ABC from fridge and allow to equilibrate to room temperature prior to use. Do not remove the seal until you have completed step 5.1.1.4
 - 5.1.1.2 Verify that the seal is intact. Do not use if buffer level is too low or seal has been compromised. A fill tolerance of ± 1 mm is acceptable.
 - 5.1.1.3 Invert the ABC, then tilt it slightly to move most of the buffer to the larger side of the container. The smaller side of the container should contain < 1 mL of the buffer.
 - 
 - 5.1.1.3.1 NOTE: If you already removed the seal and there is > 1 mL of buffer on the smaller side, use a pipette to transfer buffer to larger side of the container.
 - 5.1.1.4 Verify that the buffer is at the fill line.
 - 5.1.1.5 Peel off the seal at the top of the ABC.

FORENSIC BIOLOGY PROTOCOLS FOR FORENSIC STR ANALYSIS

PowerPlex Fusion - Capillary Electrophoresis		
Status: Published		Document ID: 5981
DATE EFFECTIVE 12/17/2021	APPROVED BY Nuclear DNA Technical Leader	PAGE 14 OF 18



- 5.1.1.6 Remove old ABC from the instrument and discard.
- 5.1.1.7 With the RFID label toward the instrument, place the ABC into the anode-end of the instrument, below the pump. Position the anode in the large chamber of the ABC, then push the ABC up and back to install.

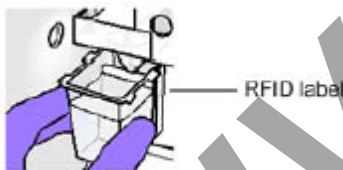

- 5.1.1.8 Close the instrument door to re-initialize.
 - 5.1.1.9 In the **Dashboard**, click **Refresh**, then check the Quick View section for updated status.
 - 5.1.1.10 Ensure that the updated anode buffer lot number is added to the LIMS Usage log for the instrument.
- 5.1.2 Cathode Buffer Container (CBC)
- 5.1.2.1 Remove CBC from fridge and allow to equilibrate to room temperature prior to use. Do not remove the seal until you have completed step 5.1.2.5
 - 5.1.2.2 Wipe away condensation on the CBC exterior with a lint-free tissue.
 - 5.1.2.3 Check that the seal is intact. Do not use if buffer level is too low or seal has been compromised. A fill tolerance of $\pm 0.5\text{mm}$ is acceptable.

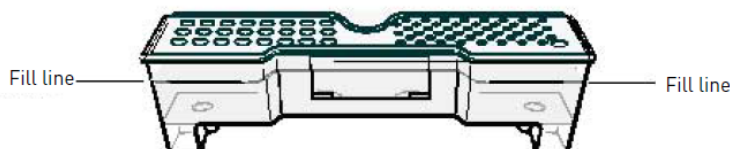

- 5.1.2.4 Tilt the CBC back and forth gently and carefully to ensure that the buffer is evenly distributed across the top of the container. If you do not tilt the CBC back and forth, the buffer can stick to the top because of surface tension.

FORENSIC BIOLOGY PROTOCOLS FOR FORENSIC STR ANALYSIS

PowerPlex Fusion - Capillary Electrophoresis		
Status: Published		Document ID: 5981
DATE EFFECTIVE 12/17/2021	APPROVED BY Nuclear DNA Technical Leader	PAGE 15 OF 18

- 5.1.2.5 Verify that the buffer is at or above the fill line.
- 5.1.2.6 Place new CBC container on a flat surface and peel off the seal.

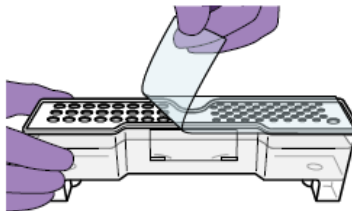

- 5.1.2.7 Wipe off any buffer on top of the CBC with a lint-free tissue. Ensure that the top of the container is dry. Moisture can cause termination of a run.
- 5.1.2.8 Place the appropriate septum on each side of the CBC:
 - 5.1.2.8.1 Align the buffer septum (the part that is symmetrical) over the 24 holes of the CBC.
 - 5.1.2.8.2 Push the septum lightly into the holes to start and then push firmly to seal it.
 - 5.1.2.8.3 Align the capillary washing septum over the other chamber of the CBC.
 - 5.1.2.8.4 Push the septum lightly into the holes to start and then push firmly to seal it.

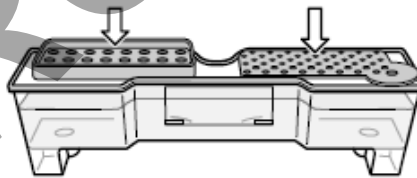

- 5.1.2.8.4.1 NOTE: Look at the CBC from the side and ensure there is no gap between the container and lip of the septum.

- 5.1.2.9 Click the Tray button on the front panel of the 3500xL instrument to move the autosampler to the front position.
- 5.1.2.10 After the autosampler has completed moving, open the door and carefully remove the old CBC from instrument and discard.
- 5.1.2.11 With the tab facing you and the RFID tag to the right, install the CBC on the autosampler. When properly installed, the CBC tabs will click as you snap them into place on the autosampler.

FORENSIC BIOLOGY PROTOCOLS FOR FORENSIC STR ANALYSIS

PowerPlex Fusion - Capillary Electrophoresis		
Status: Published		Document ID: 5981
DATE EFFECTIVE 12/17/2021	APPROVED BY Nuclear DNA Technical Leader	PAGE 16 OF 18

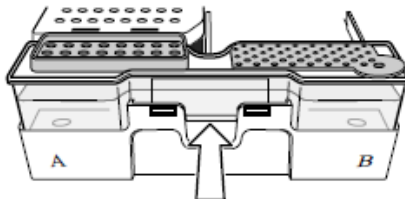

- 5.1.2.12 Click the Tray button to retract the autosampler, then close the instrument door to initialize.
- 5.1.2.13 The cathode buffer lot number information will be entered into the individual 3500xL batch within LIMS.
- 5.2 In the **Dashboard**, click **Refresh**, then check the Quick View section for updated status.

ARCHIVED

FORENSIC BIOLOGY PROTOCOLS FOR FORENSIC STR ANALYSIS





PowerPlex Fusion - Capillary Electrophoresis		
Status: Published		Document ID: 5981
DATE EFFECTIVE 12/17/2021	APPROVED BY Nuclear DNA Technical Leader	PAGE 17 OF 18

6 Troubleshooting

Instrument		
Symptom	Possible Cause	Action
Autosampler does not move the plate to a higher position	The plate base is not sitting properly on the autosampler.	The plate base should sit flat on the autosampler. When placing the plate on the autosampler, ensure that the pins in the autosampler are properly aligned with the holes at the bottom of the plate base, and that the left and right sides are latched.
	The plate retainer is lifted off the plate base by array.	Securely clip the plate retainer and plate base together.
	The septum is lifted off the CBC.	Ensure that the septum is completely inserted into position. Listen for the light clicking sound that occurs when the septum is pressed down firmly into position.
When you remove the heat seal from a new pouch, some residual seal remains on top of the pouch. 	The top seal of the pouch has become delaminated and left the polyethylene behind on the pouch cap. Pouch did not equilibrate to room temperature.	Use a pipette tip to remove the entire seal from the pouch cap before installing on the instrument.
Error Messages		
Symptom	Possible Cause	Action
“Bubble” error	Bubbles present	Run the Remove Bubbles wizard.

FORENSIC BIOLOGY PROTOCOLS FOR FORENSIC STR ANALYSIS

PowerPlex Fusion - Capillary Electrophoresis		
Status: Published		Document ID: 5981
DATE EFFECTIVE 12/17/2021	APPROVED BY Nuclear DNA Technical Leader	PAGE 18 OF 18

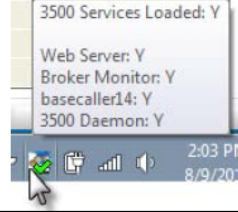
Dashboard		
Symptom	Possible Cause	Action
Consumables status in the Dashboard is not updated.	Dashboard does not update automatically.	Click Refresh .
After installing new CBC or ABC, the consumables status in the Dashboard is not updated automatically.	Dashboard does not update automatically.	Click Refresh after changing or installing consumables.
Software		
Symptom	Possible Cause	Action
<p>Status icon is  instead of .</p> 	<p>One or more of the services are stopped.</p>	<p>Hover the mouse pointer over the status icon. If any item does not display a checkmark, select  <input type="checkbox"/> Programs <input type="checkbox"/> Applied Biosystems <input type="checkbox"/> 3500 <input type="checkbox"/> Server Monitor.</p> <p>Right-click the status icon, then select Services. If any item does not display a checkmark, click the item to start the service.</p> 
Create Injection List and Start Run buttons dimmed	The Pause After Last Injection preference is set, and the instrument is paused.	Go to Monitor Run and resume the run. When the run is complete, Create Injection List and Start Run buttons are active.