



**Faisal Muhammed, PE**

Executive Director, Cranes + Derricks

**Bill Halkiadakis, PE**

Deputy Director, Cranes + Derricks

## **Crane Safety**

**Electric Cranes, Aging Cranes +  
the 2014 Codes**

2014 BUILD SAFE | LIVE SAFE  
**CONFERENCE**

**NYC**  
Buildings

# American Institute of Architects Continuing Education System

---

The NYC Department of Buildings is a registered Provider with The American Institute of Architects Continuing Education Systems (AIA/ CES). Credit earned on completion of this program will be reported to AIA/CES for AIA members. Certificates of Completion for both members and non-AIA members are available upon request.

This program is registered with the AIA/CES for continuing professional education. As such, it does not include content that may be deemed or constructed to be an approval or endorsement by the AIA of any material of construction or any method or manner of handling, using, distributing, or dealing in any material or product.

Questions related to specific materials, methods, and services will be addressed at the conclusion of this presentation.



# Copyright Materials

---

This presentation is protected by US and International Copyright laws. Reproduction, distribution, display and use of the presentation without written permission of the speaker is prohibited.



## Course Description

---

This course will provide attendees with an understanding of the importance of safe practices and early planning for the construction requiring electrically powered tower cranes.

This course will review safety issues with older cranes and review the safety provisions adopted in the 2014 NYC Building Code as it relates to construction, installation and inspection of Cranes & Derricks.



# Learning Objectives

---

Participants will examine the various types of tower cranes and be able to discuss the advantages and disadvantages that pertain to each “machine”.

Participants will learn about the temporary electric service process and be able to apply these requirements in order to demonstrate effective early planning strategies.

Participants will review Crane Modernization , which limits the operating age of Cranes in New York City and be able to describe the safety issues associated with older cranes.

Participants will review and be able to apply the 2014 NYC Building Code requirements related to construction, installation, inspection and maintenance of Cranes & Derricks.



# Mechanical Hoists in High-Rise Construction

---

Derrick is a lifting device with a mast held at the head with guys or braces. Derricks come with a boom for use with a hoisting mechanism and operating ropes.

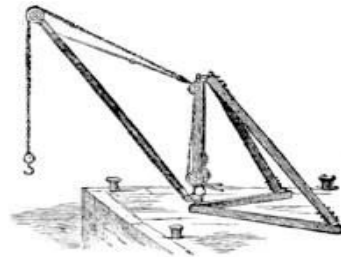

First major steam-powered derrick was used in building construction in Brooklyn circa-1878.

Derricks were used as primary hoisting equipment for all major high-rise construction because of their ease of assembly and use.

# Mechanical Hoists in High-Rise Construction

---

Derricks come in ranges of 5 to 350 tons of lifting capacity.

The standard use of derricks in building construction in New York City is up to 35-ton lifting capacity.

Derricks are mostly used in New York City high-rise construction to erect or dismantle tower cranes.

The advent of the tower cranes, circa-1930, replaced derricks as the primary mode of hoisting material in high-rise building construction.

# Derricks

---



Derrick in use to  
hoist material



# Tower Cranes in New York City Construction

---

## Concrete and Steel Buildings:

Concrete buildings require higher line speed and lower capacity to accomplish the 2 to 3 day per-floor completion cycle – **Main Object is Speed**

Steel buildings require higher-capacity and lower-line speed due to the size of the beams and columns lifted into place – **Main Object is Capacity**

## Types of Tower Cranes: Luffing

---



This type of crane consists of “A” frame and boom section mounted on machine platform

Suitable for dense urban environments

## Types of Tower Cranes: Hammerhead

---



This type of tower crane is very efficient due to horizontal movement of load along the boom – but it comes with site-specific restrictions due to long heel section.

# Types of Tower Cranes: External Climbing

---



These cranes are tied to the building through special steel ties.

## Types of Tower Cranes: Internal Climbing

---



These cranes are installed and attached inside the building through special steel ties.

Site-specific restrictions are primary reasons for this type of installation.

# Types of Tower Cranes: Internal Climbing

---



Internal climbing tower cranes require specially designed structural members.

# High-Rise Construction Is Up

---



Last year, we discussed an upcoming construction boom. We are now we are in it. Example: new residential tower at Park Avenue requiring tower cranes.

# New Building Development

---

## Current (Since Jan. 1, 2009)

Permitted	38	7,332,465 sq. ft.
Filed	28	4,513,480 sq. ft.
Total	66	11,845,945 sq. ft.

## Planned (Expected Peak Period: 2015-2018)

Hudson Yards	9,100,000 sq. ft.
Manhattan West	2,100,000 sq. ft.
New Residential Towers	1,807,520 sq. ft.
Total	13,007,520 sq. ft.

**GRAND TOTAL** **24,853,465 sq. ft.**



# Manhattan West – Cranes over Rail



# Manhattan West – New Buildings Over Rail

---



# High-Rise Construction Is Up

---



New construction at Hudson Yards requiring multiple tower cranes

# Hudson Yard Project



# Crane Inventory Registered in NYC

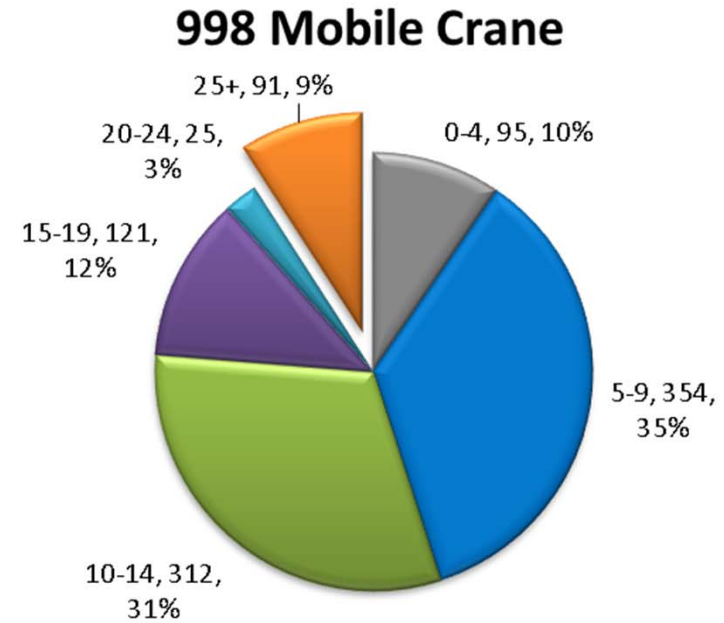
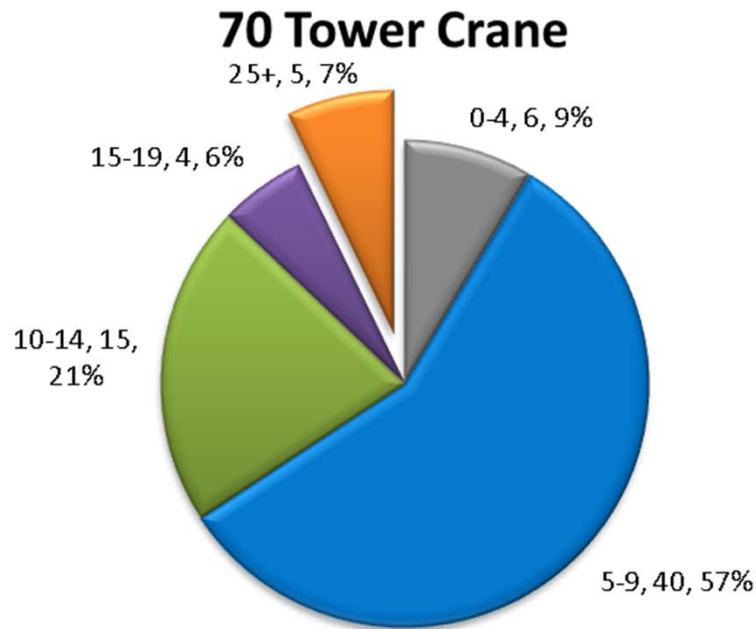

# Tower Cranes Registered in 2011

---

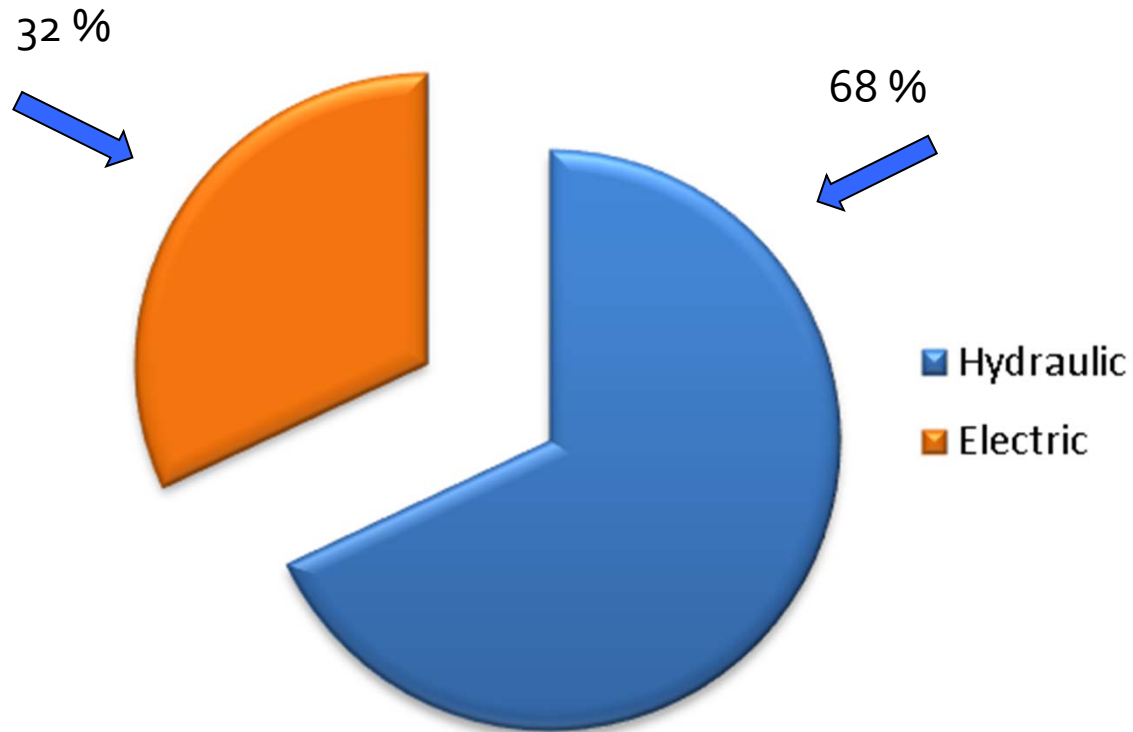

# Tower Cranes Registered in 2014

---

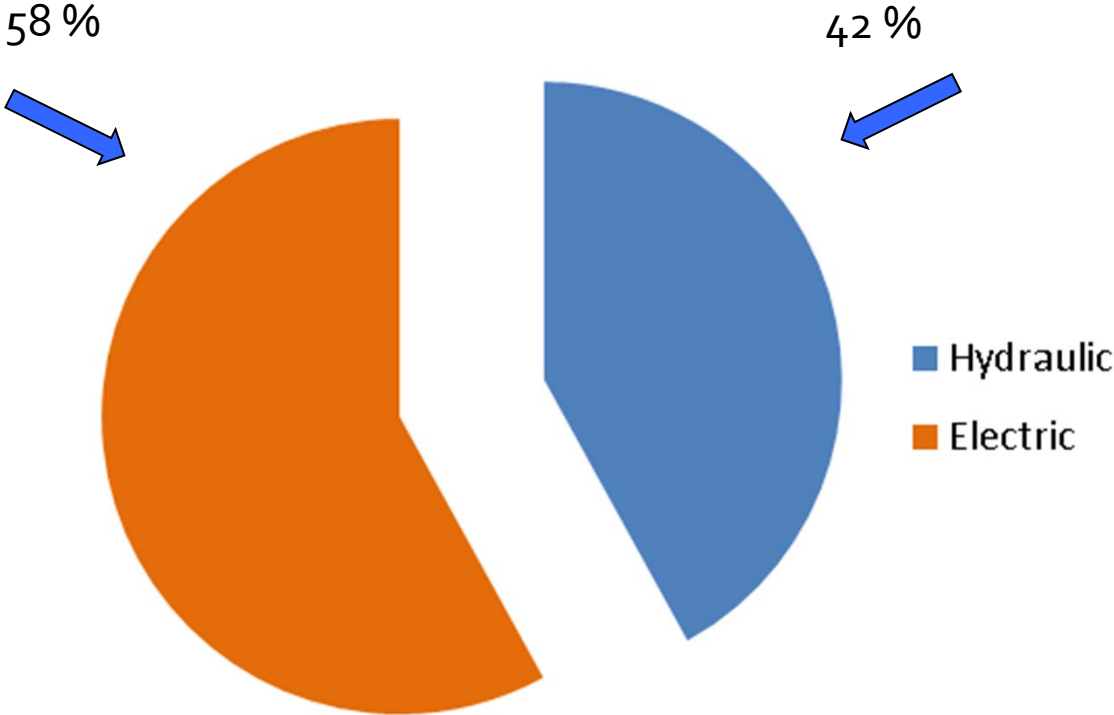

# Older Crane Challenges

---

## **OEM Support**

- Availability of parts
- Availability of qualified personnel
- Safety Bulletins

## **System “Wear and Tear”**

- Hydraulic
- Mechanical
- Electronic
- Pneumatic
- Structural integrity

## **Technological Innovations**

- No load-limiting sensors
- No automatic slow down at end positions
- No danger-area limiting devices



# Ongoing Meetings with Crane Manufacturers

---

1. DOB hosted meetings with Liebherr, Potain, Favco, Kroll, Wolffkran, Terex/Comedial and Cornell Co.
2. ASME/ANSI B30.3 Edition “Tower Cranes” has been released and replaces the 2009 version of ASME B30.3.

Includes major changes and additions to scope of work for erecting, dismantling and climbing tower cranes

New consideration of the impact of wind zone regions across the US

Adopted Unified EN 14439 standard for tower crane safety.

3. Liebherr, Potain, Kroll, Wolffkran, Terex/Comedial are already following European Unified Standard EN 14439 for tower crane manufacturing.
4. New prototype procedures were discussed and communicated.

## European Unified Standard EN 14439

---

Significant manufacturers have adopted EN 14439 on all cranes manufactured and sold since January 1, 2010 because of the benefits to users and owners:

Increased construction site and operator safety by using anti-collision system, improved operator cabin visibility and PLC programs and numerous positive limit switches that shut off the crane when the crane is outside set parameters.

Improved safety for erectors and users by standardized crane-climbing protocol and modified working platforms.

# Features Based on EN 14439: Improved Limit Switches in Luffing Cranes for Safer Operation

## Luffing Limit Switches on MR 295

A limit switch with reduction gear driven either directly by the drum shaft or through a pinion meshing a toothed ring rigidly fixed to the drum records the number of revolutions and so the wound rope length. This reduction gear drives cam (1) which act on the circuit breakers (2) thus cutting off the corresponding movement.

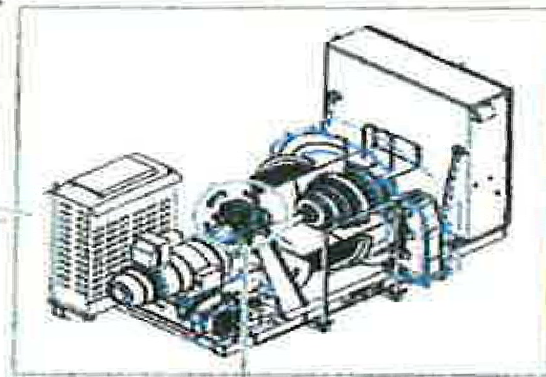
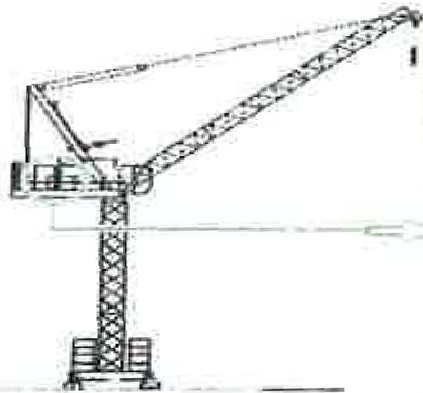

**Luffing up**  
**Luffing down**  
**Upper decelerating**  
**Lower decelerating**  
**Weathervanning**  
**Upper overrun**  
**Lower overrun**

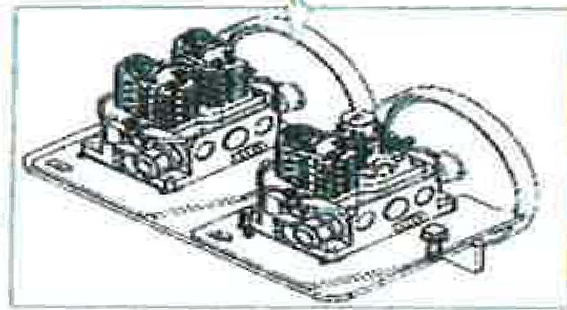
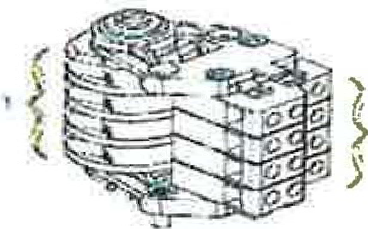

Upper overrun

# Features Based on EN 14439: Crane Operator Comfort and Safety From Better Visibility

- ▶ Ultra View cab
- ▶ Optimum front and side visibility
- ▶ Air conditioned as standard

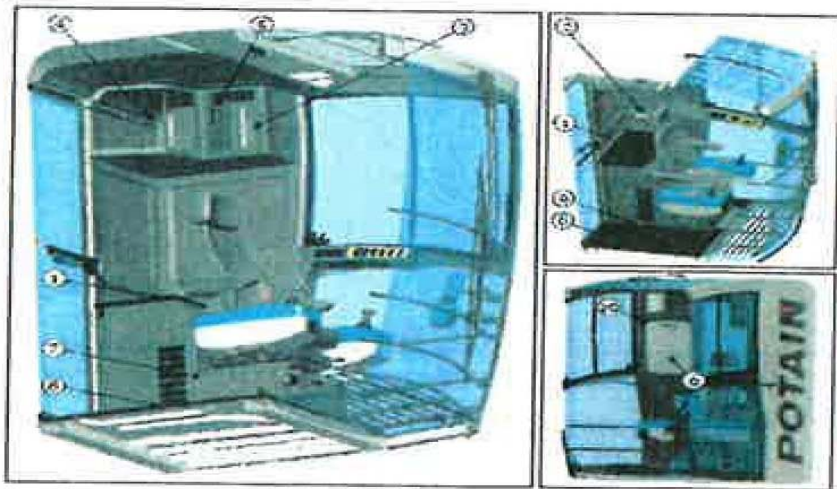

1. Table
2. Set of 3 plugs
- 3/4/5. Storage compartments
6. Information zone
7. Place for fire extinguisher
- 8/9. Antiskid carpet
10. Cloth hanger

# Features Based on EN 14439: Anti-Collision System for Protected Zones

---

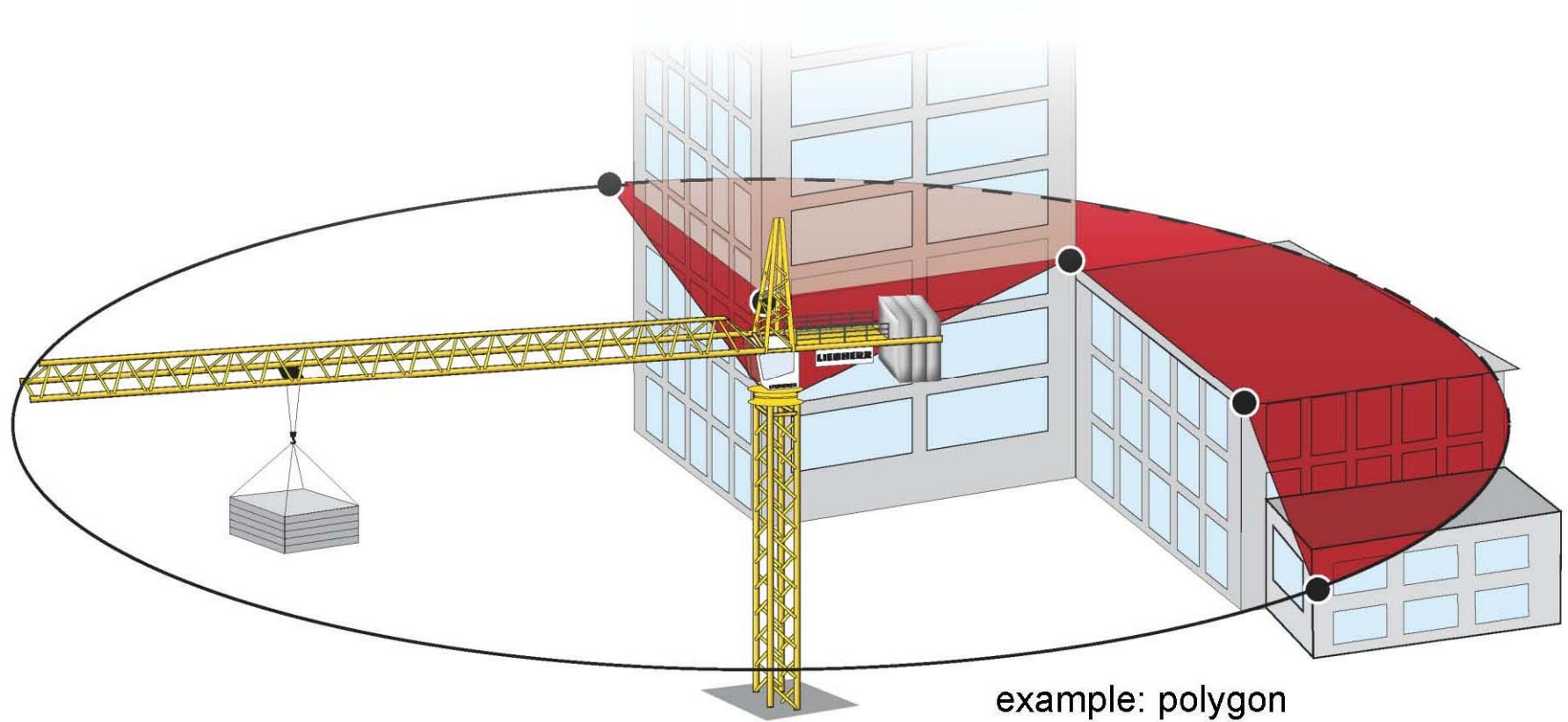

# Features Based on EN 14439: Embedded Camera for Safer Load Pickup and Delivery

---

**CAMERA:** Embedded camera on trolley gives the crane operator the ability to always have an eye on his load whatever the jobsite configuration is.



# Features Based on EN 14439: Modified Safe Working Platforms

---

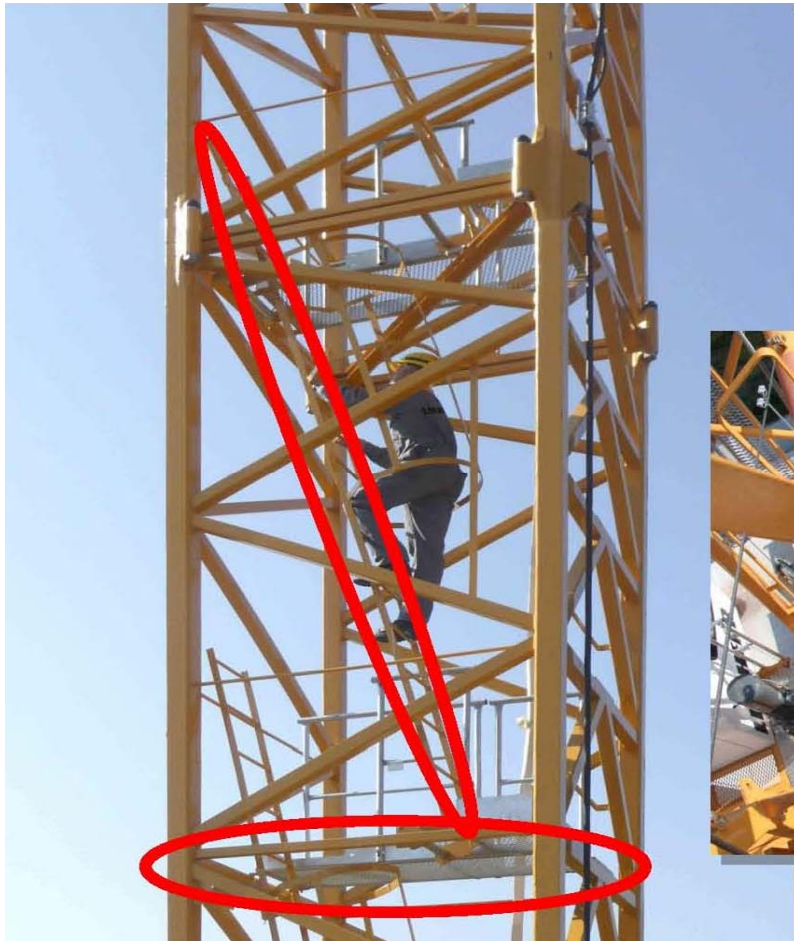

# Features Based on EN 14439: Modified Safe Working Platforms

---





# Features Based on EN 14439: Standardized Climbing Protocol

---



# Features Based on EN 14439: Component Tracking for Safe Use of Repaired Components

## Advanced Technology to Track Crane Components

- Manitowoc offers to fit RFID tags on crane's major components (mast element, jib element, counter jib element, tie bars, cab, winches, ...)

Help customer to manage Cranes fleet and to monitor components maintenance and lifecycle.

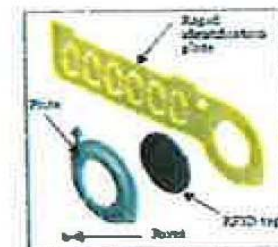

The RFID tag direction does not matter. Reading is possible from both sides.

This chip is read by an RFID reader/recorder (example: PDA type transmitter/receiver) which picks up the information and transmits it towards an electronic data processing system.



The electronic chip contains a single identifier (serial number), information entered by Manitowoc and possible additional data recorded by the customer by means of an RFID reader/recorder.

# Advantages of New Tower Cranes

---

Designed using current technology and latest means and methods

Computer-aided interface (LMI – Load Moment Indicator)

Crane operator driving aid: embedded camera

More advanced positive limit switches prevent overloading and over/under booming

Crane operator comfort and safety

Anti-collision system

Advanced technology to track cranes components

# Crane Modernization – Background

---

The Department conducted a detailed study regarding crane modernization:

- Discussed design life criteria for cranes with all renowned crane manufacturers.
- Reviewed and inspected crane operations in the City.
- Communicated and discussed their operational practices and maintenance procedures.
- Met with authorities of other jurisdictions (Singapore, Australia, etc.) and discussed their regulatory practices.

## Crane Modernization – Background Continued

---

Based on the discussions and a detailed study, the Department concluded that an age limitation should be imposed on all cranes working in the City.

This decision is based on the fact that most of the cranes in the City are not exclusively used in City and detailed record of maintenance and use is often not available.

# Hydraulic and Electric Tower Cranes

---

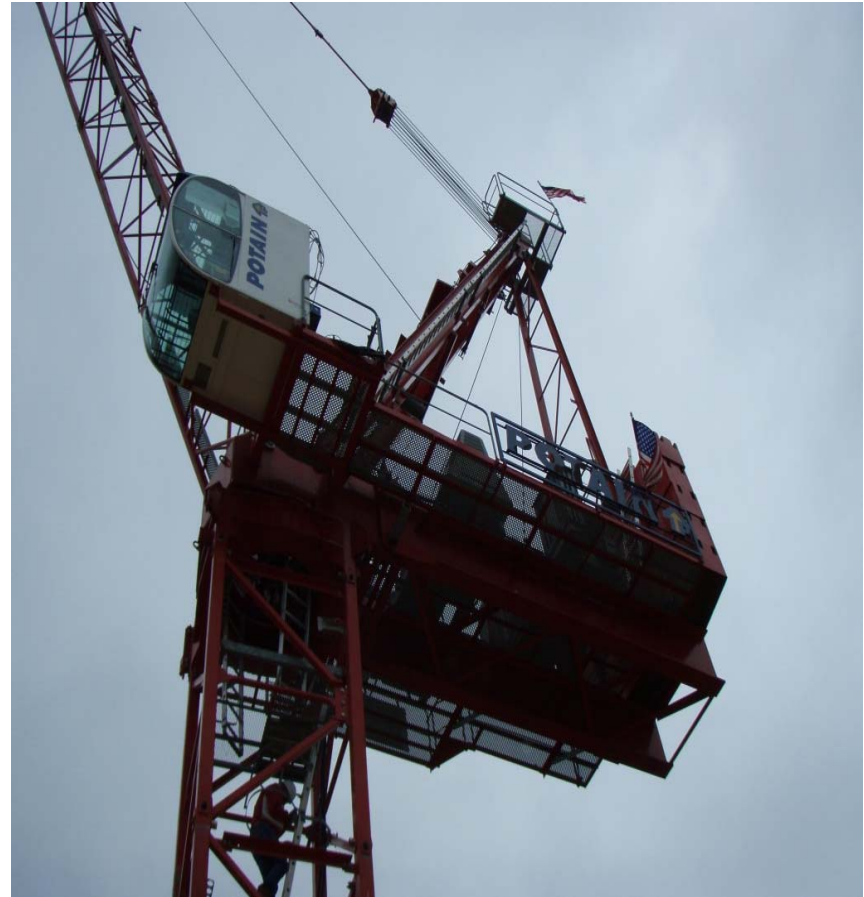

# Transition to Electric Tower Cranes

---

Most major tower crane manufacturers switched from hydraulic to electric in the 1970s due to technologically advanced mechanics and:

- Variable speed more advanced hoisting winch

- Energy efficiency: decreased power required

- Less maintenance required

- Environmental advantages (less noise / no pollution)

## Facilitating New Tower Cranes

---

The Department modified its tower crane prototype acceptance protocol and invited tower crane manufacturers to submit crane design and manufacturing documentations for expedited approval.

Since most tower crane manufacturers produce only electric tower cranes (Liebherr, Potain, Terex, Wolff, and Kroll), adequate electric service must be provided to all sites utilizing tower cranes.

The Electrical Committee was created to examine industry practice of requesting and supplying adequate electric power to sites.



# Technical Bulletin to Clarify Prototype Process

## BUILDINGS BULLETIN 2013 – 2017

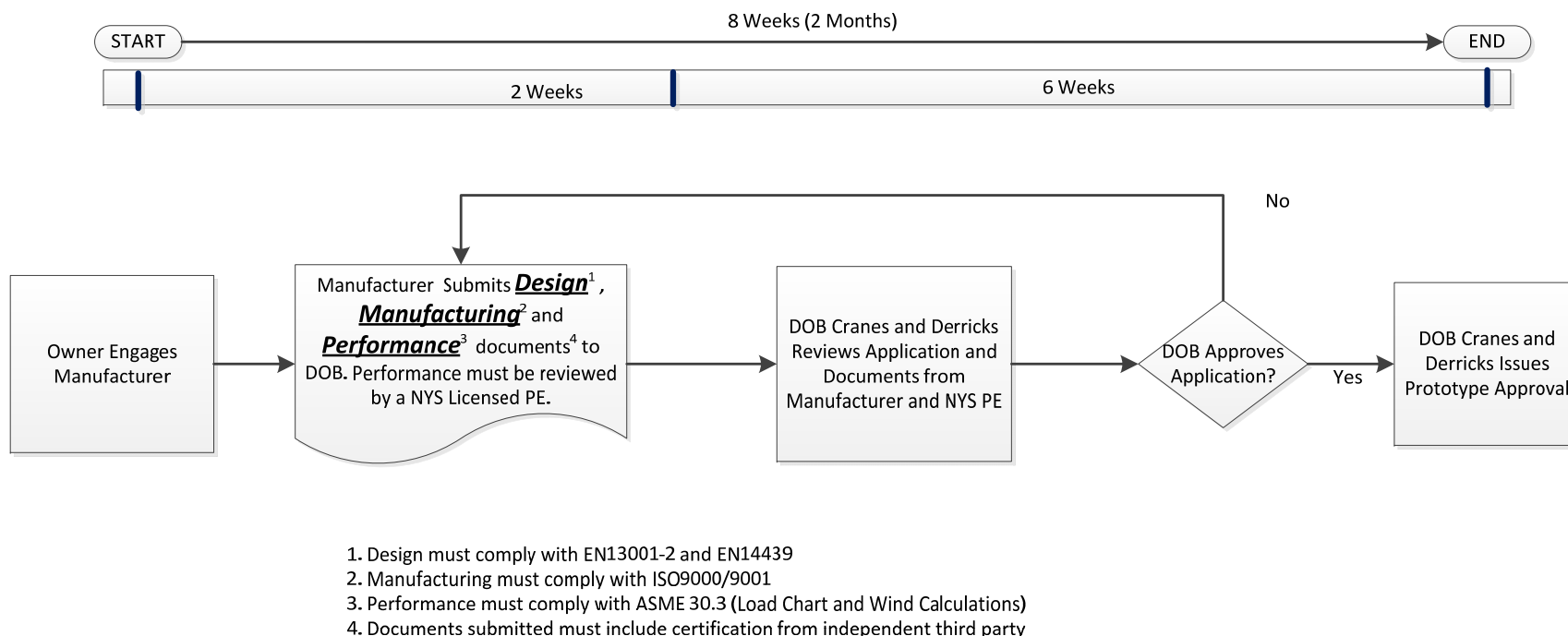

# Electrical Committee Meetings

---



# Electrical Committee Discussion – Background

---

The typical electrical construction demand of a high-rise building (40 stories) without an electrical tower crane is approximately 1800 amps (550 kW, 208V). A typical electrical tower crane consumes 800 amps (244 kW, 208V).

The total service requirement for a construction site utilizing an electrical tower crane is increased by 44%.

## Typical Tower Crane Power Requirements

Liebherr – 884 amps (208V)

Potain/Manitowoc – 811 amps (208V)

Wolffkran – 722 amps (208V)

# Electrical Committee Discussion

---

## Temporary Power Requirements

What are the temporary power requirements of a construction site that utilizes an electrical tower crane?

# Electrical Committee Discussion

---

## Availability of Power

What is the availability of the power in the local electrical grid to supply power to construction sites when required?

# Electrical Committee Discussion

## Con Edison Example: Robust Area Grid

7 Transformers

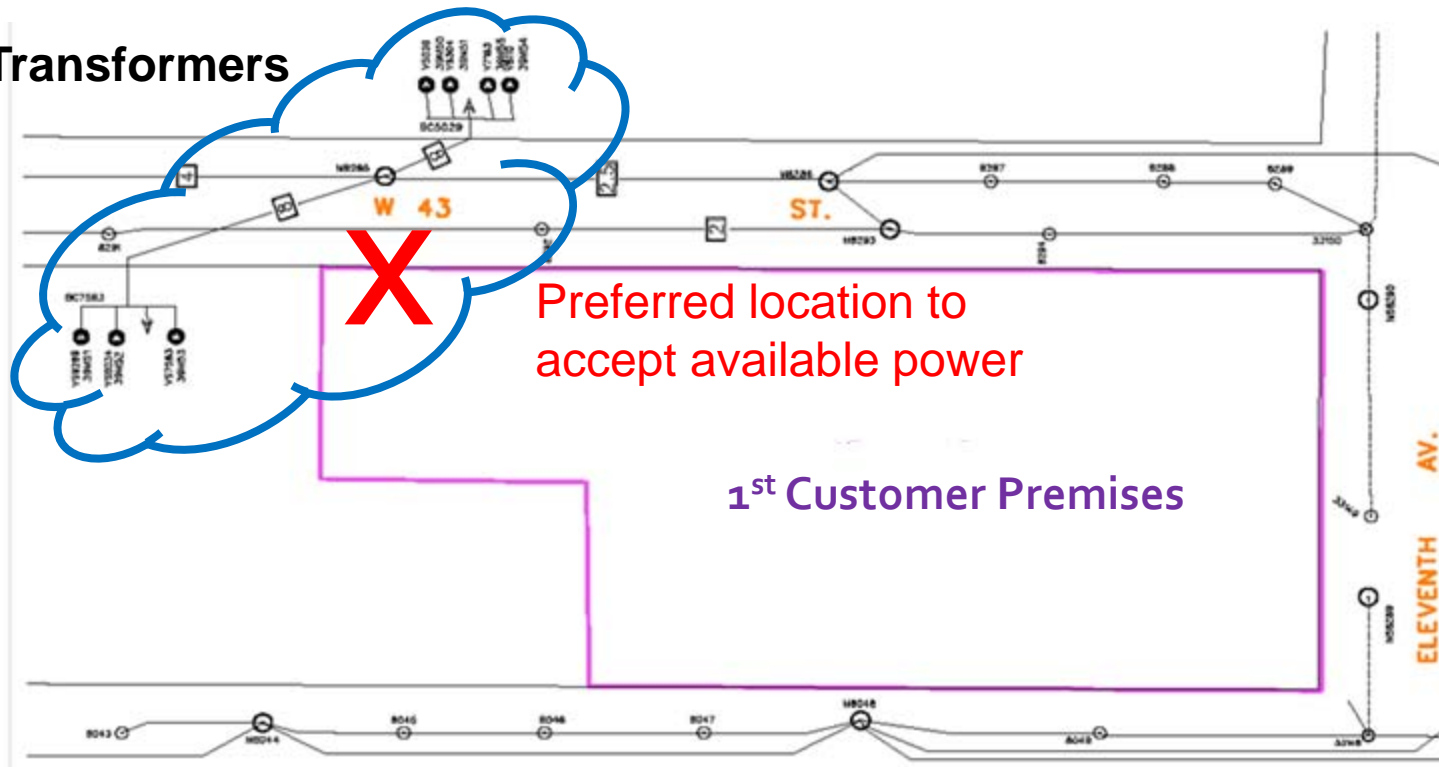

# Electrical Committee Discussion

## Con Edison Example: Weak Area Grid

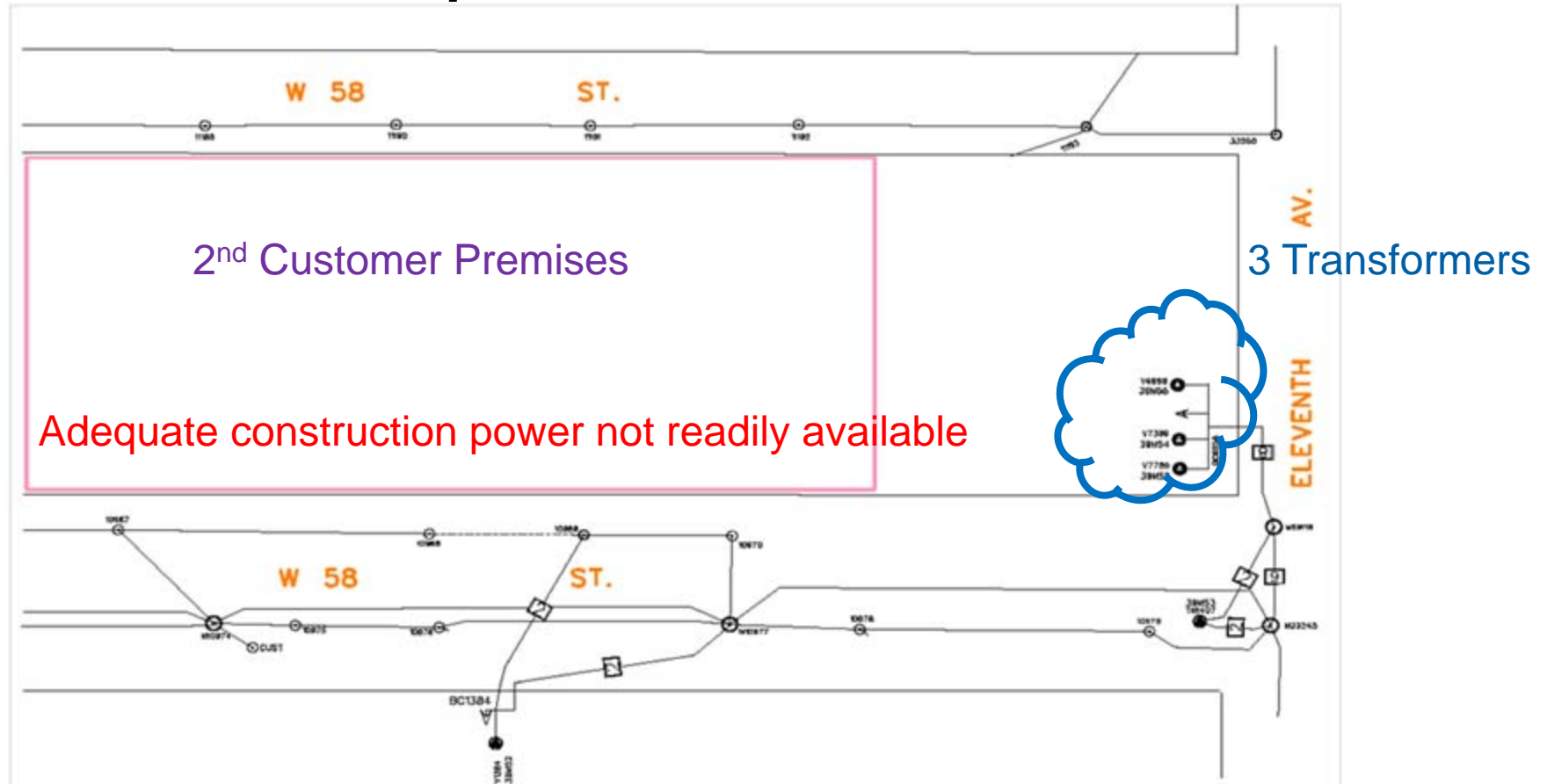

# Electrical Committee Discussion

---

## Requesting Temporary Service

When should electrical contractors/engineers for the developers request temporary electric service for construction sites?



# Electrical Committee Discussion

---

## Current Practice

Temporary service requests are often submitted with limited time before the construction service is needed (6 months).

## Proposal

A temporary load letter and service request should be submitted concurrently with the permanent service request.

This strategy will allow Con Edison 19 months of lead time to ensure that the adequate infrastructure is in place to supply electrical power to a construction site.

# Electrical Committee Discussion

## Typical Timeline: 40-story New Building Construction and Electrical Power Requirement

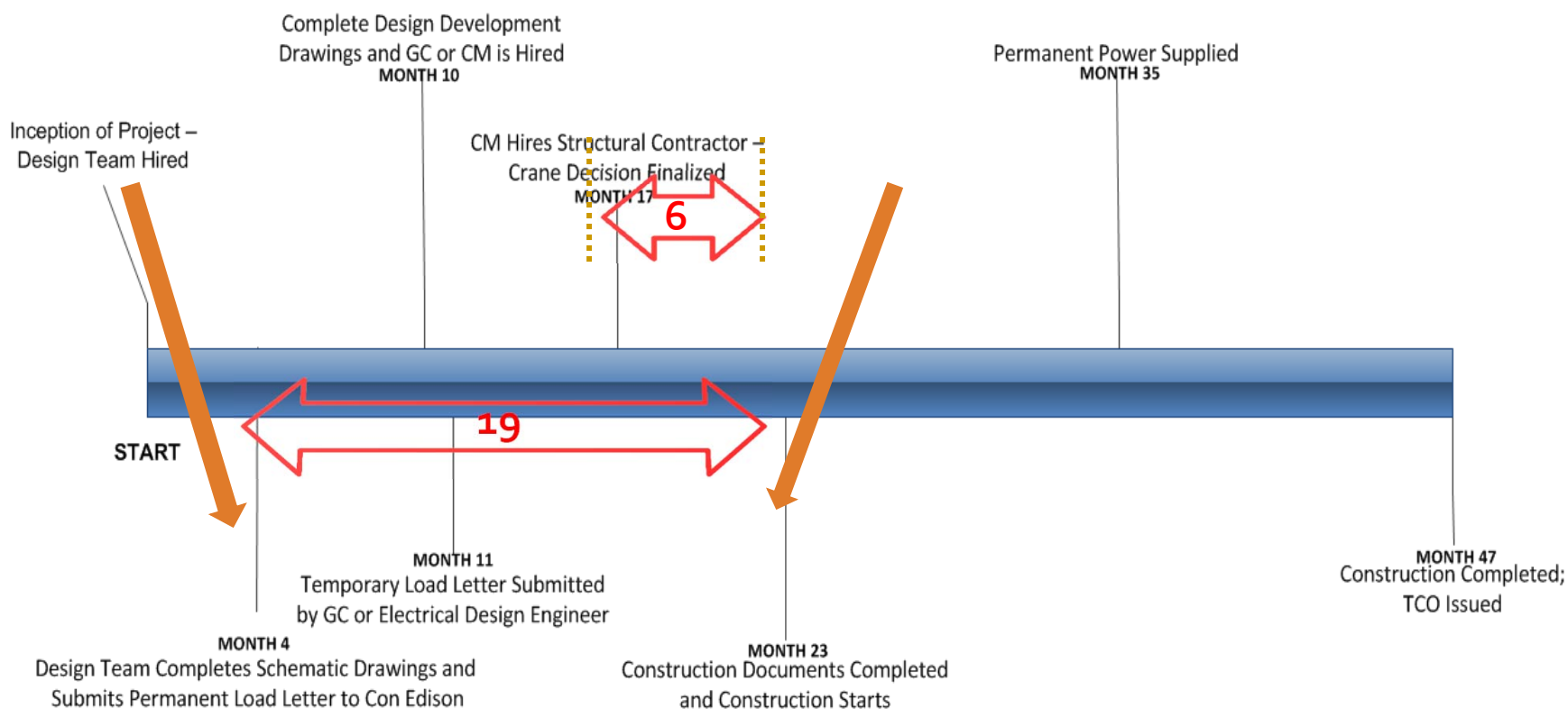

# Electrical Committee Discussion

---

## Findings

Electrical tower cranes will substantially increase power requirements of construction sites.

Temporary service requests must be requested early in the process.

## 2014 Changes to NYC Code Chapter 33

---

### **Revised Supervisory Requirements for the Hoisting and Lowering of Articles on the Outside of Buildings**

The revised rigging changes to the 2014 NYC Building Code have been added under Section 3316.9.

The revised section establishes training and supervisory requirements for rigging work performed by a contractor.

Requires critical picks to be planned by a licensed master rigger or registered design professional.

Authorizes licensed riggers or contractors to hoist or lower materials in conjunction with façade work where a site safety plan is required.

Requires a licensed rigger for all other façade and alteration work that does not constitute a vertical or horizontal enlargement.

## 2014 Changes to NYC Code Chapter 33

---

**3316.9 Rigging.** The attachment and detachment of articles from hoisting equipment used to hoist or lower articles on the outside of buildings shall be in accordance with the requirements of Sections 3316.9.1 through 3316.9.3

This sections applies to:

- Hoisting and lowering

- On the outside of the building

- With hoisting equipment

- Where an article is attached or detached from hoisting equipment.

## 2014 Changes to NYC Code Chapter 33

---

**3316.9.1 Supervision.** The hoisting or lowering of any article on the outside of any building in the city shall be performed by or under the direct and continuing supervision of a licensed rigger.

Section 3316.9.1 is a new section in the 2014 Code.

Article 28-404.1 of the Administrative Code has been amended in the 2014 Code to allow “*The hoisting of articles on the outside of a building in the city*” to be “*hoisted or lowered by or under the supervision of a qualified and/or competent person*” where so authorized by Chapter 33.

## 2014 Changes to NYC Code Chapter 33

---

This section provides those details in relation to hoisting equipment, specifically when a licensed rigger or foreman is required, and when the hoisting can be supervised by another individual.

When a licensed rigger is utilized, all work must be performed “*by*” the licensed rigger, or “*under the direct and continuing supervision*” of the licensee.

The rigger can appoint a rigging foreman to provide onsite supervision on behalf of the licensee. The foreman and the rigging crew must be on the payroll of the licensee.

## 2014 Changes to NYC Code Chapter 33

---

There are four exceptions regarding the hoisting and lowering “*by or under the direct and continues supervision*” of a licensed rigger:

**Exception 1:** Cross-reference the licensed sign hangers.

**Exception 2:** Cross-reference the requirements for suspended scaffolding.

**Exception 3:** Authorizes contractors to hoist or lower articles at certain construction, demolition and alteration sites without supervision by a licensed rigger.

**Exception 4:** Authorizes the use of a specialty crew.



## 2014 Changes to NYC Code Chapter 33

---

**Section 3316.9.1 Exception 3** states that:

“In lieu of a licensed rigger, the hoisting or lowering of articles on the outside of a building may be performed by or under the supervision of a **competent person** designated by the contractor using the equipment provided the following conditions are met: ...”

**All** the provisions of exception 3 (including all sub items) must be met in order for the contractor to hoist or lower articles. If one or more of the items are not met, the hoisting or lowering must be performed *“by or under the direct and continued supervision of a licensed rigger”*.

## 2014 Changes to NYC Code Chapter 33

---

A **competent person** may be used for hosting and lowering that occurs in conjunction with new building construction, full demolition of a building, vertical or horizontal enlargement and façade work.

Supervision by a **competent person** designated by the contractor or a specialty certified crew may not be used for following crane related work:

- Tower crane assembly, jumping or disassembly.

- Hoisting or lowering that meets the definition of a critical pick.

## 2014 Changes to NYC Code Chapter 33

---

**Exception 3** does not prohibit a licensed rigger from supervising hoisting or lowering at a construction, demolition or alteration site listed in the exception, since it only provides an alternative to the licensed rigger.

The contractor could still utilize a licensed rigger in one of the following two fashions:

Rigging work could be performed *“under the direct and continuing supervision of a licensed rigger”* with a crew under the direct employment of the licensee.

The general contract could designate a licensed rigger or a rigging foreman employed by the rigger as the **competent person**, with a crew that would be certified and trained but under the direct employment of the general contractor.

# 2014 Changes to NYC Code Chapter 33

---

## Critical Picks

Section 3316.9.1 Exception 3.6 states that:

Where the hoisting or lowering meets the definition of a critical pick, such critical pick is:

3.6.1 Performed in accordance with a plan developed by either a:

3.6.1.1 Licensed master rigger; or

3.6.1.2 Registered design professional who has demonstrated knowledge or experience with safe loads and computation thereof, types of rigging, size and strength of ropes, cables, blocks, and any other rigging equipment to be used during the critical pick;

# 2014 Changes to NYC Code Chapter 33

---

## Onsite Verification for Critical Picks

Section 3316.9.1 Exception 3.6.2 states that:

Immediately prior to the pick, onsite verification is made to ensure conformance with the plan by either:

The licensed master rigger who developed the plan;

The registered design professional who developed the plan; or

A registered design professional employed by and working under the direct supervision of the registered design professional who developed the plan.

# 2014 Changes to NYC Code Chapter 33

---

## Specialty Crew Provisions

**Section 3316.9.1 Exception 4** states that:

Where the hoisting or lowering is performed under the direct and continuing supervision of a licensed rigger, a specialty crew who is not in the direct employ of the licensee or business of the licensee may be utilized, provided:

The work requires a specialty trade, including but not limited to work with hazardous materials or chemicals;

The crew is in accordance with rules promulgated by the commissioner; and

The members of the crew are approved by the commissioner

## 2014 Changes to NYC Code Chapter 33

---

**Exception 4** authorizes the use of a specialty crew; where work is performed “under the direct and continuing supervision” of a licensed rigger (for example, one of the other exceptions does not apply), the licensed rigger may supervise individuals not under his or her “direct employ” provided the conditions in exception 4 are met.

These provisions are derived from the specialty crew option currently found in Rigging Rule 9.

# Safe Crane Operations – Inclement Weather

---



The Department implemented operational changes both in field and during engineering review of crane applications based on lessons learned from Hurricane Sandy



# Safe Crane Operations – Inclement Weather

---

## Inclement Weather Advisory Related to Crane Operations

Site-specific plan for crane operations during storm conditions

Implementation and details of the site-specific plan on engineering plans and communication details for site personnel by engineer (applicant of record)

# Safe Crane Operations – Inclement Weather

---

## Example of Typical Wind Requirements

Load Capacity Reductions for wind speeds 15 - 35 mph

WIND REQUIREMENTS		
		LR1200
		REDUCTION BY %
WIND SPEED (mph)	up to 15	0
	up to 20	10
	up to 25	10
	up to 30	20
	up to 35	30
	Over 35	OPERATION NOT PERMITTED

# Safe Crane Operations – Inclement Weather

---

## Typical Crane Laydown Specifications

### LR1200

- **Up to 35 mph** – Park Crane (upper in line with crawlers) position boom at 80 deg and luffer between 63 and 70 deg.
- **35mph to 50 mph** – Position crane as shown on Jack-Knife parking position.
- **Above 51 mph** - Lower boom to the ground on block.

# Safe Crane Operations – Inclement Weather

---

## Typical Jack-Knife Parking Position

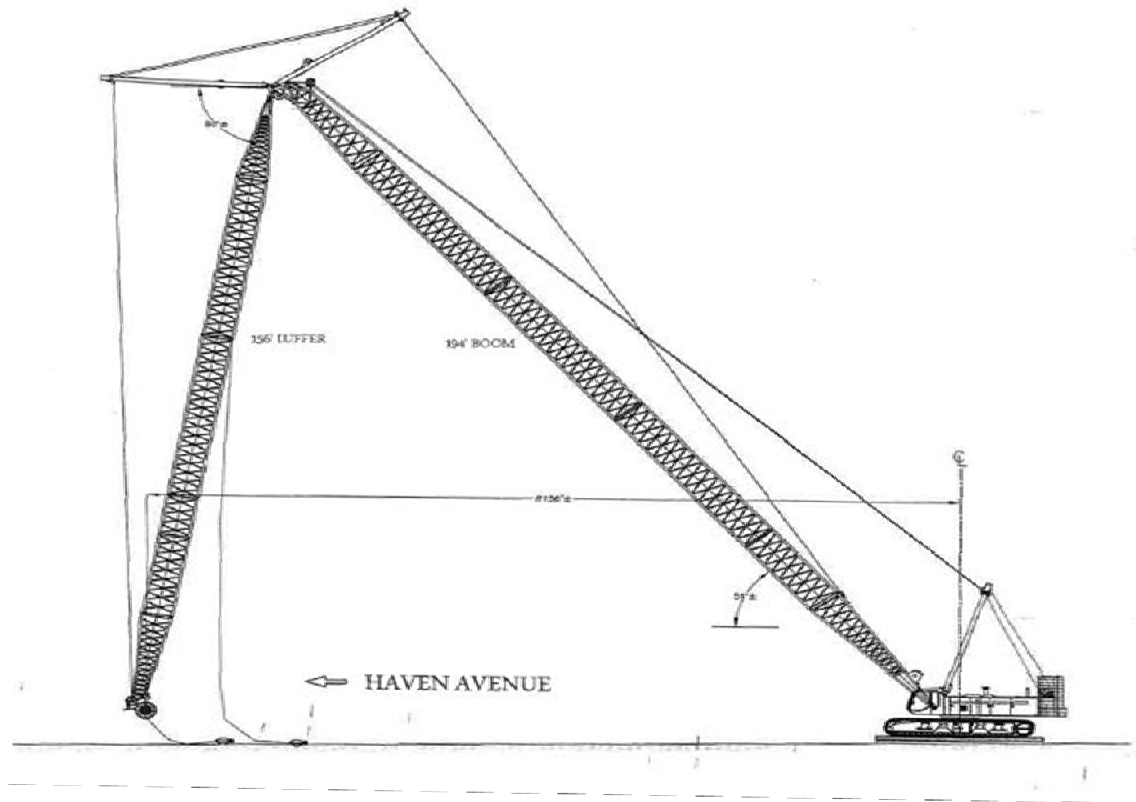

# Safe Crane Operations – Inclement Weather

## Typical Laydown Plan for High Winds

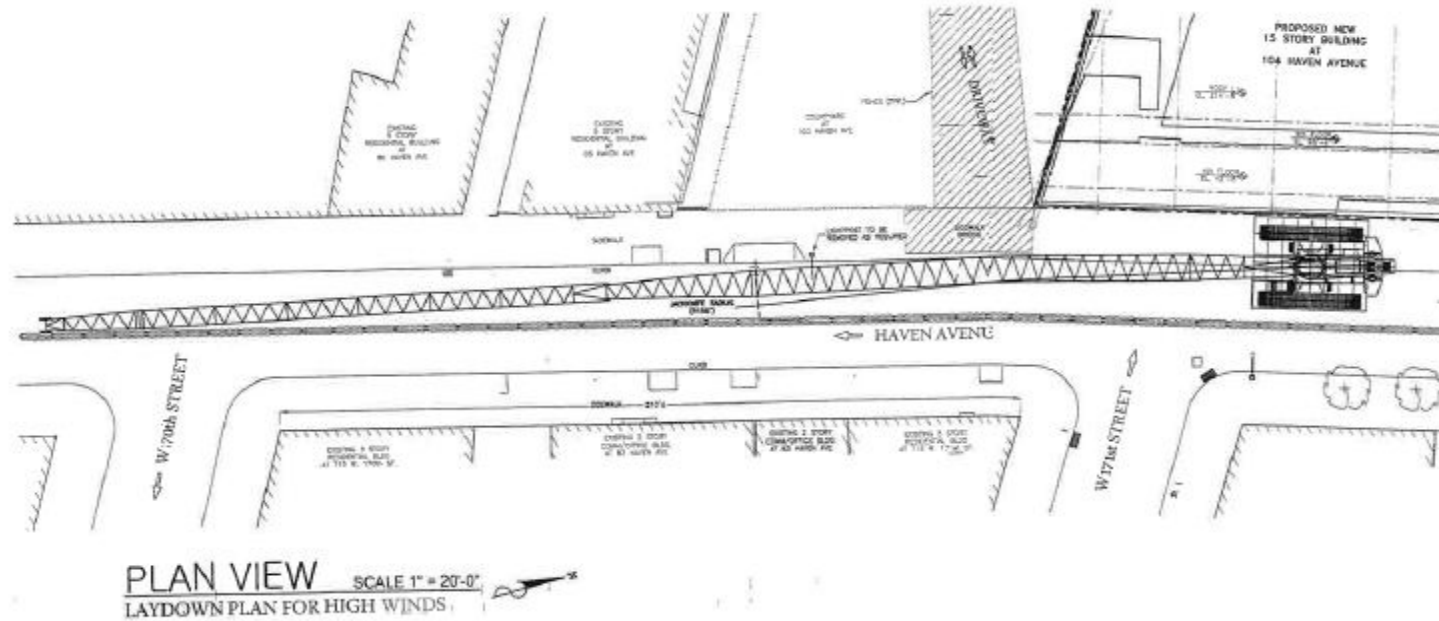

# Site Safety Plans and Crane Operations

---

## Coordination between Site Safety Plans & Crane Notices (CNs)

### Previous Review Process

An approved site safety plan was required prior to the CN approval and erection of the crane.

### Current Review Process

Only an approved CN is required prior to the **erection and load test** of the crane.

Approved site safety plan required prior to crane **use**.

# Site Safety Plans and Crane Operations

---

## Benefits to the Construction Industry

Site safety plans and crane notices (CNs) can be reviewed simultaneously.

The crane **can be erected and load tested** while the site safety plan is being reviewed.

However, the crane **cannot be used** until the site safety plan is in compliance with the crane application.

The responsibility for ensuring coordination of the site safety plan and the CN belongs to the CM/GC and or permit holder.

# Site Safety Plans and Crane Operations

---

## **Incorporate Crane Operations into 3D Site Safety Plans**

Leverage 3D construction model for regulatory compliance, crane operations and site safety

Add to the design/construction model to include crane location, crane operations and site safety information

Develop BIM models to illustrate the interaction of building construction and the phasing of crane erection and operations

Develop automations to streamline the review and regulatory compliance of critical crane operations.



# 3D Site Safety Plans and Crane Operations

---

## Example of a 3D Site Safety Plan

Major Building, Manhattan

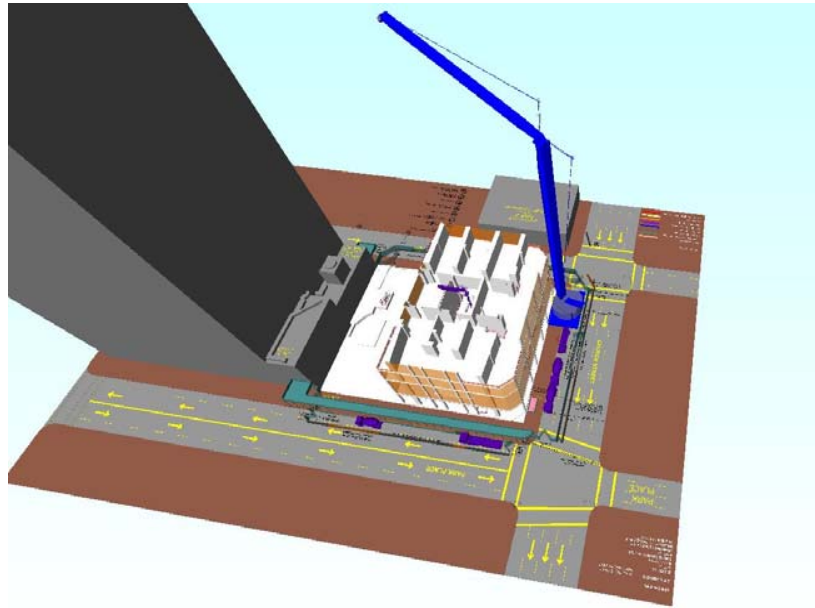

The 3D site safety plan should focus on the logistics and the protection of the public and adjoining property.

The SSP should illustrate the location of the crane, the “pick” location and the adjacent pedestrian protection.

# 3D Site Safety Plans and Crane Operations

---

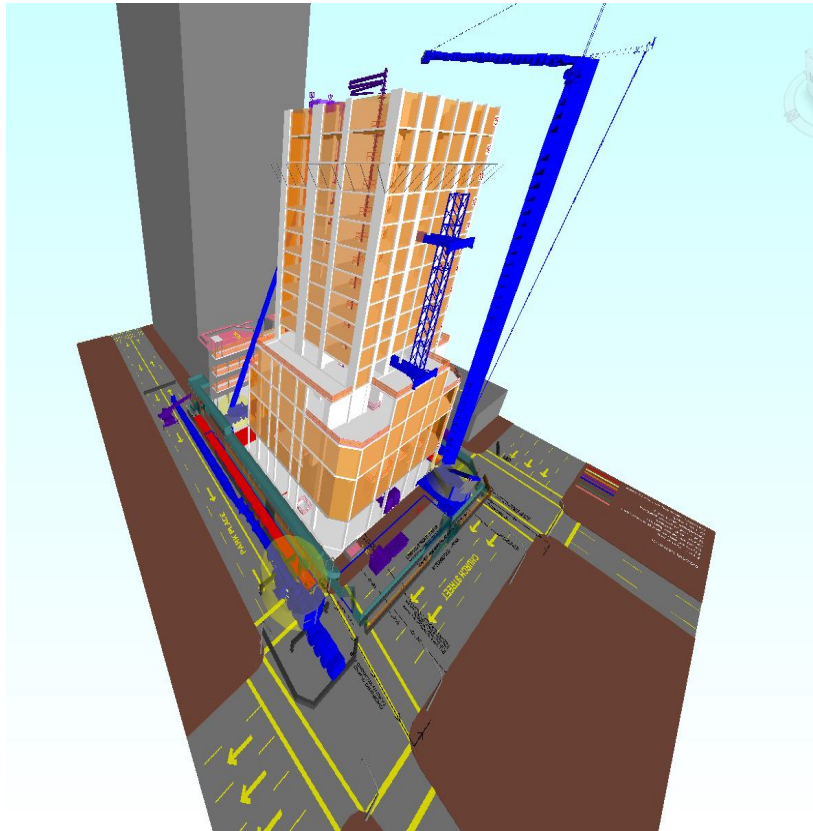

The 3D site safety plan should depict the phasing of the crane erection, and it must agree with the underlying CN design documents.

The obligation and responsibility of the compliance of the site safety plan with the CN design documents belongs to the CM/GC and/or permit holder and his site management team.

# 3D Site Safety Plans and Crane Operations

---

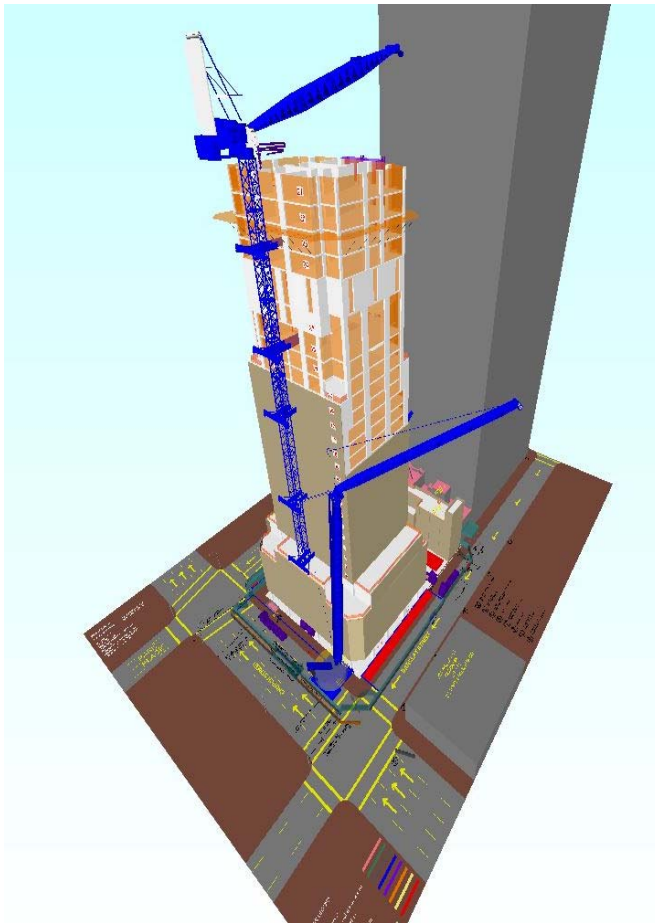

Enforcement of compliance between the site safety plan and the underlying CN design documents will be the responsibility of the inspectors.

If the approved CN and the site conditions are out of compliance with the site safety plan, a violation will be issued.

# 3D Site Safety Plans and Crane Operations

---

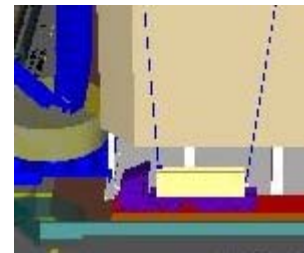
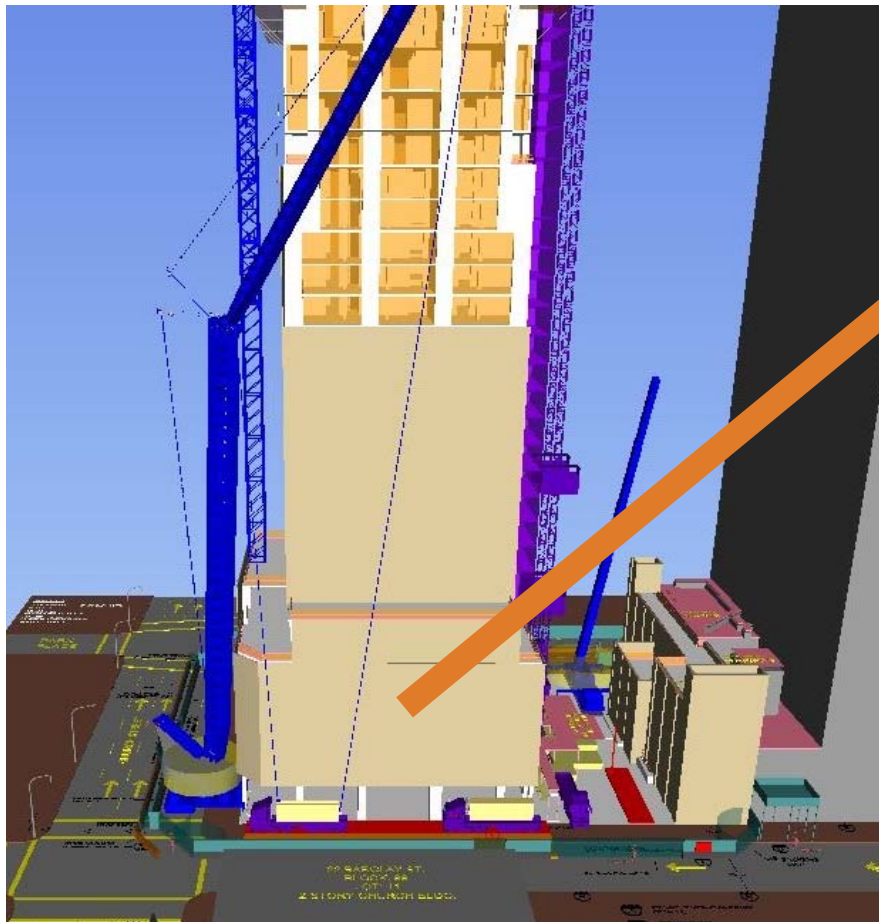

The 3D site safety plan should illustrate critical lifting operations.

## Questions?

---

This concludes the American Institute of Architects Continuing Education System course.

### **AIA Contact:**

Allison Ginsburg

[aginsburg@buildings.nyc.gov](mailto:aginsburg@buildings.nyc.gov)

212.393.2167