

August 13, 2024
Public Hearing

The current proposal is:

Preservation Department – Item 5, LPC-24-11718

**130 West 57th Street – 130 West 57th Street Studio Building –
Individual Landmark
Borough of Manhattan**

To testify virtually, please join Zoom

Webinar ID: 854 0834 7928

Passcode: 643937

By Phone: 646-558-8656 (NY)

877-853-5257 (Toll free) US

888-475-4499 (Toll free)

Note: If you want to testify virtually on an item, join the Zoom webinar at the agenda's "Be Here by" time (about an hour in advance). When the Chair indicates it's time to testify, "raise your hand" via the Zoom app if you want to speak (*9 on the phone). Those who signed up in advance will be called first.

130 WEST 57TH STREET

RETAIL STORE: EXTERIOR SIGNAGE

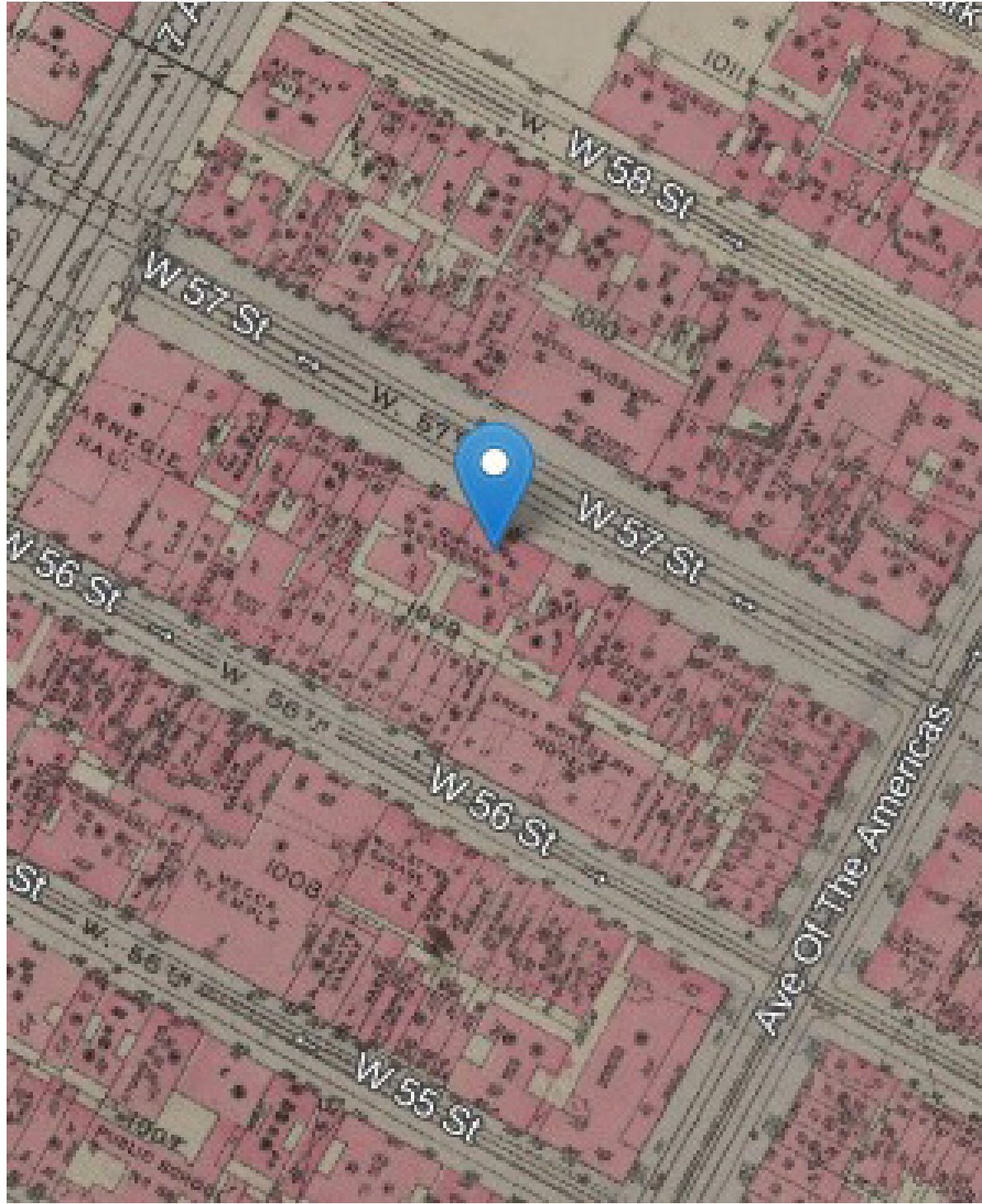

SANBORN MAP
1892



NEW YORK CITY TAX PHOTOGRAPH
1940



SITE PLAN



SITE MAP



AREA OF WORK



STOREFRONT

130 & 140 WEST 57TH STREET
1909



STOREFRONT

BUILDING DESIGNATION PHOTOGRAPH
1999



BUILDING DESIGNATION PHOTOGRAPH
1999



BUILDING DESIGNATION PHOTOGRAPH
1999



130 West 57th_ Current Storefront



130 West 57th_ Existing Metal Cladding



130 West 57th_Existing Detail Images



130 West 57th_Existing Stair & Vestibule

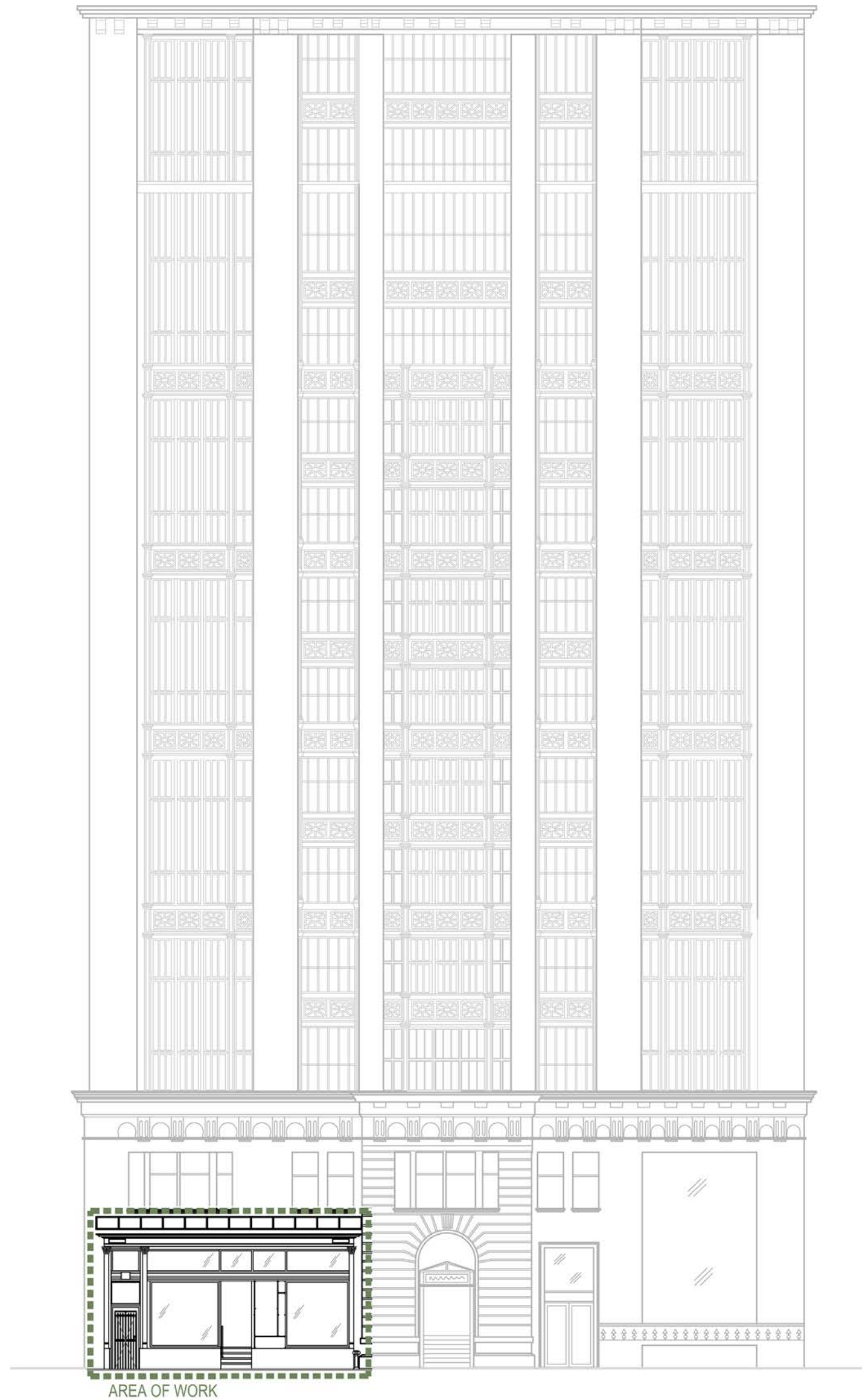

130 West 57th_ Existing Building Facade Elevation

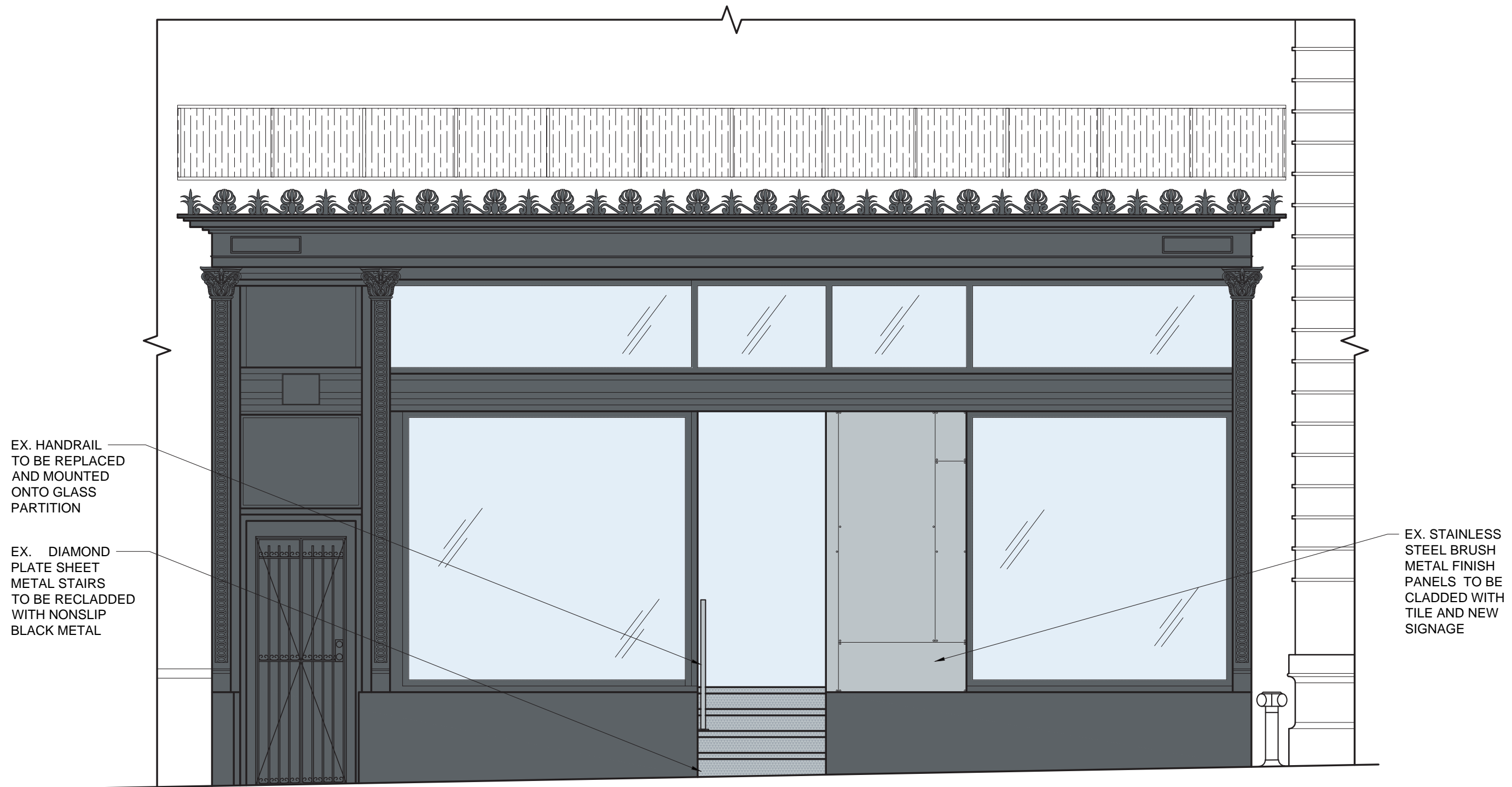

130 West 57th_ Existing Storefront Elevation

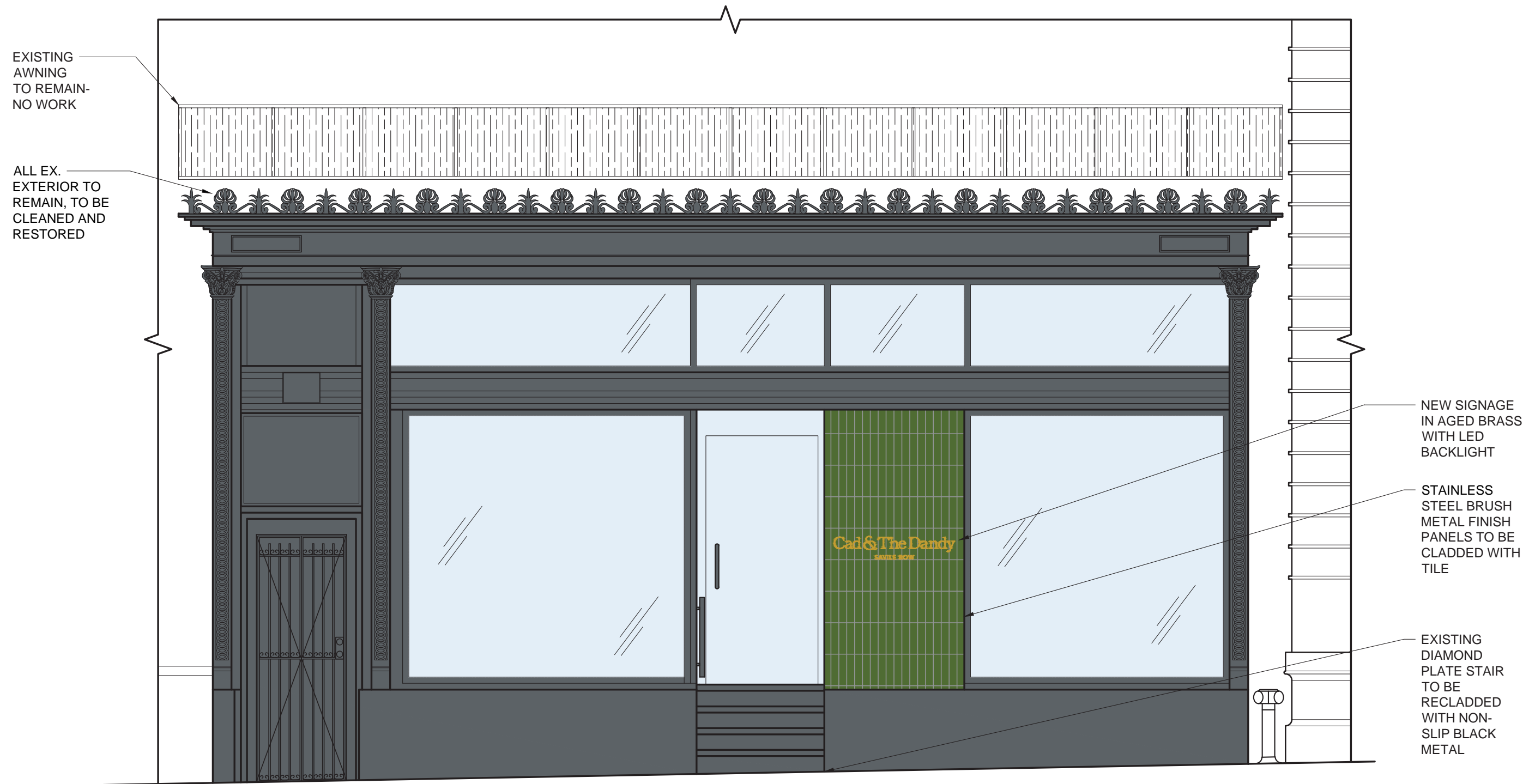

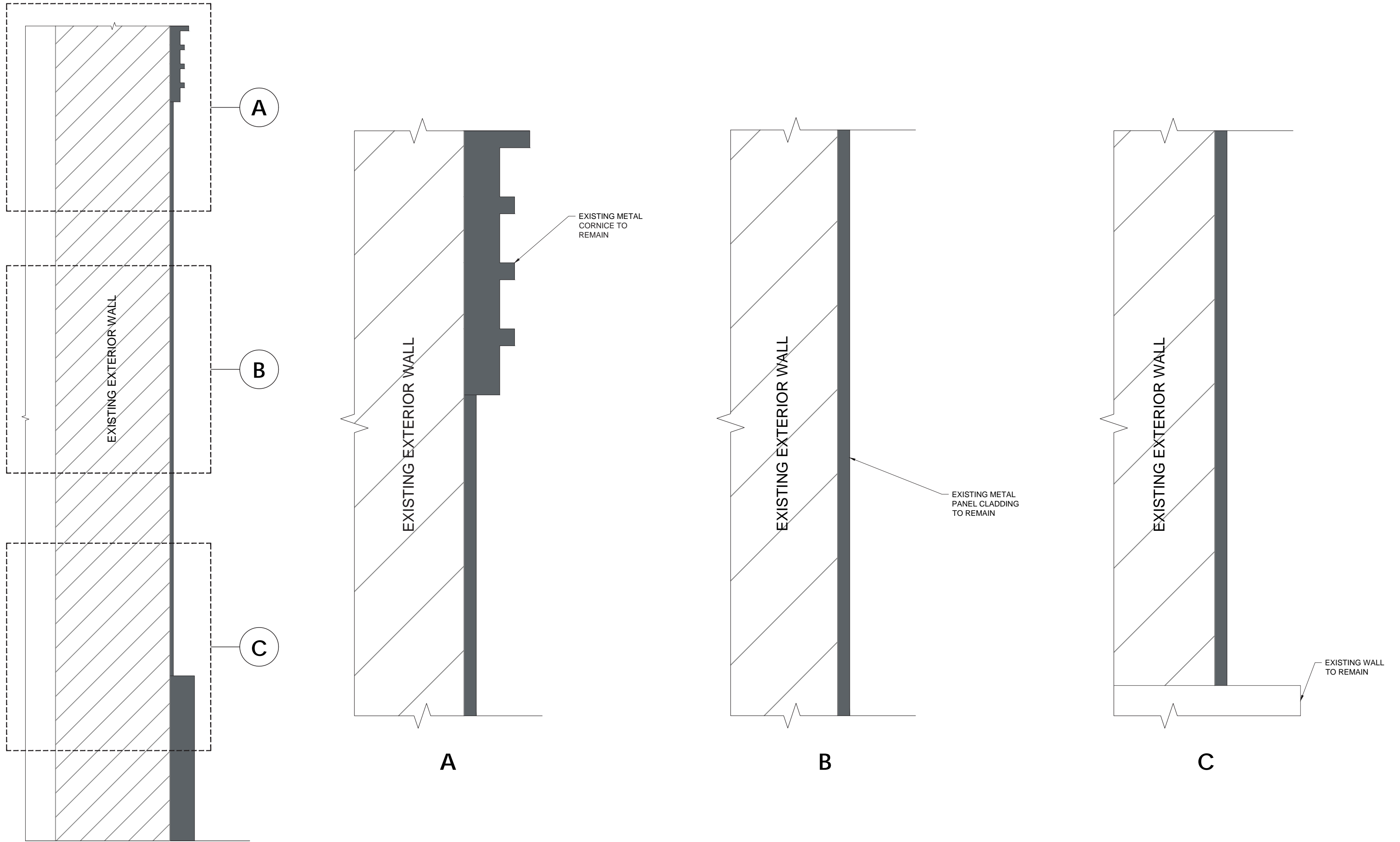

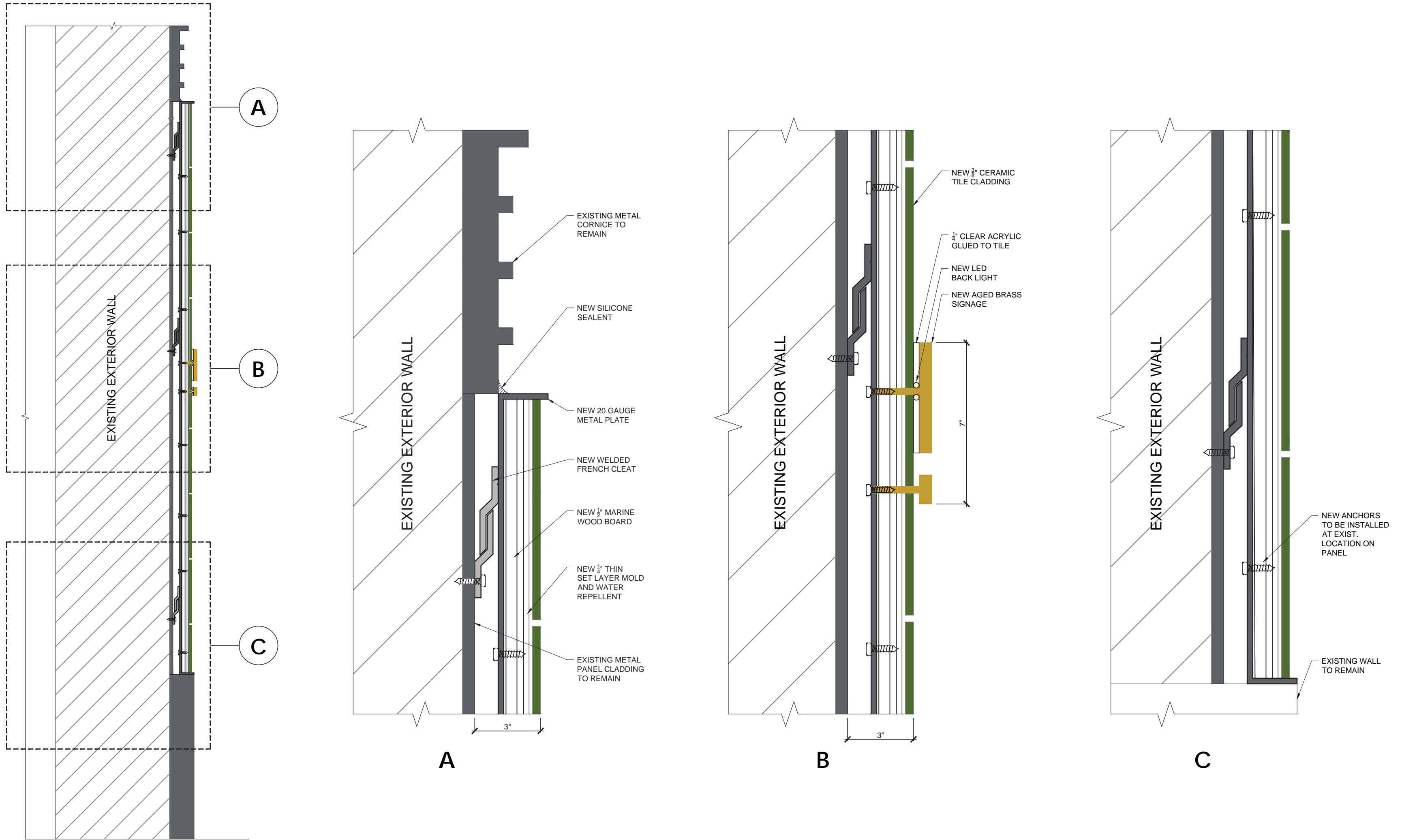

130 West 57th_Proposed Cladding Details

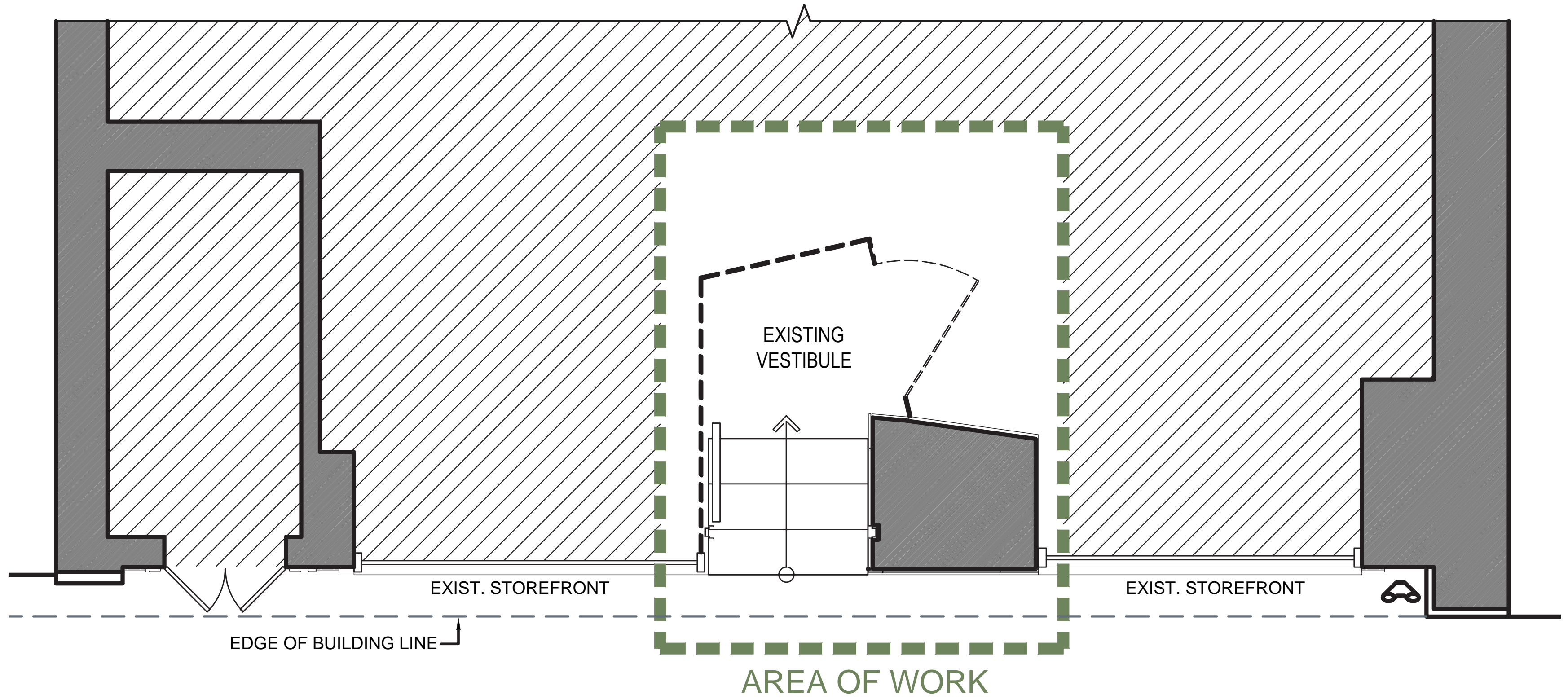

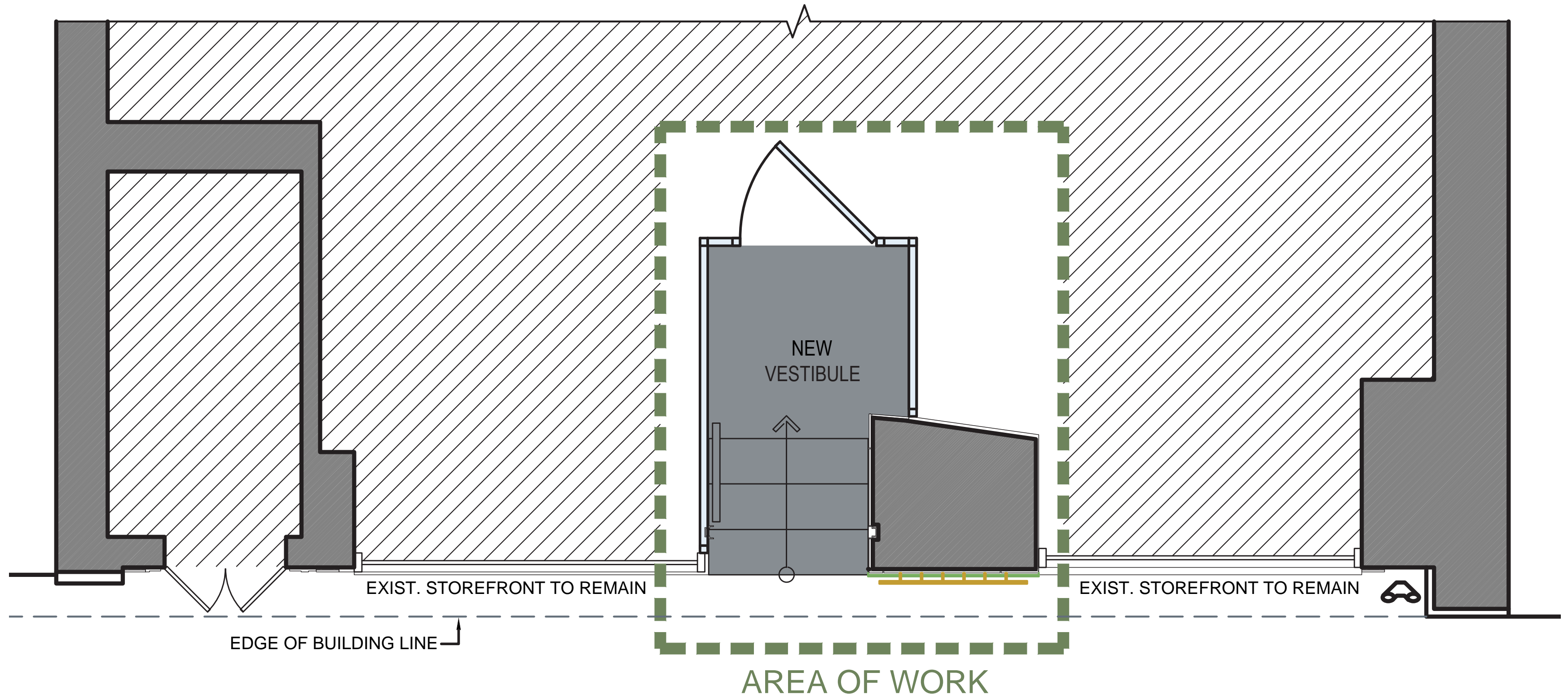

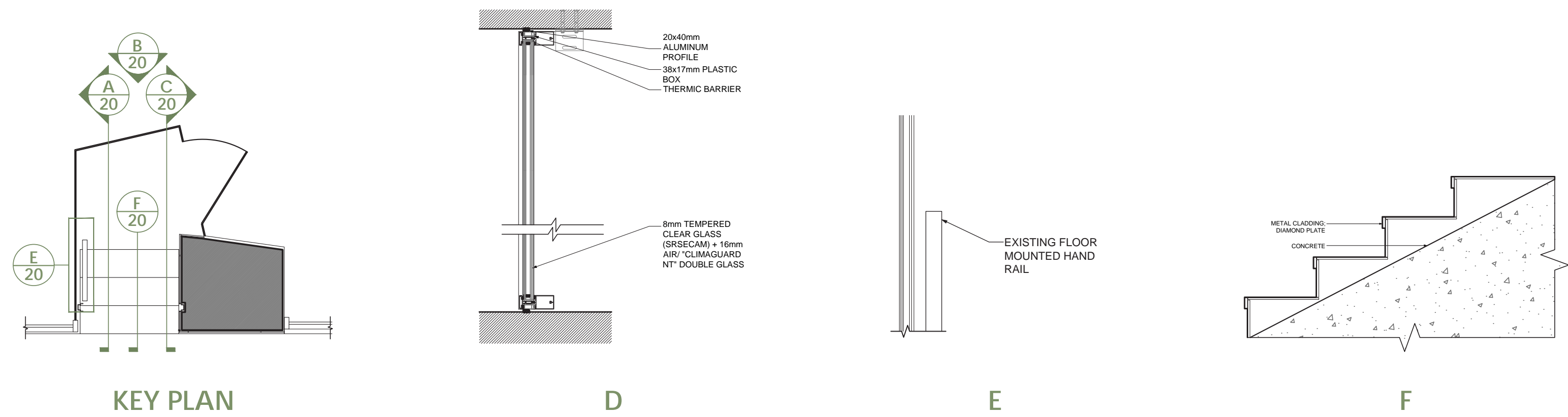
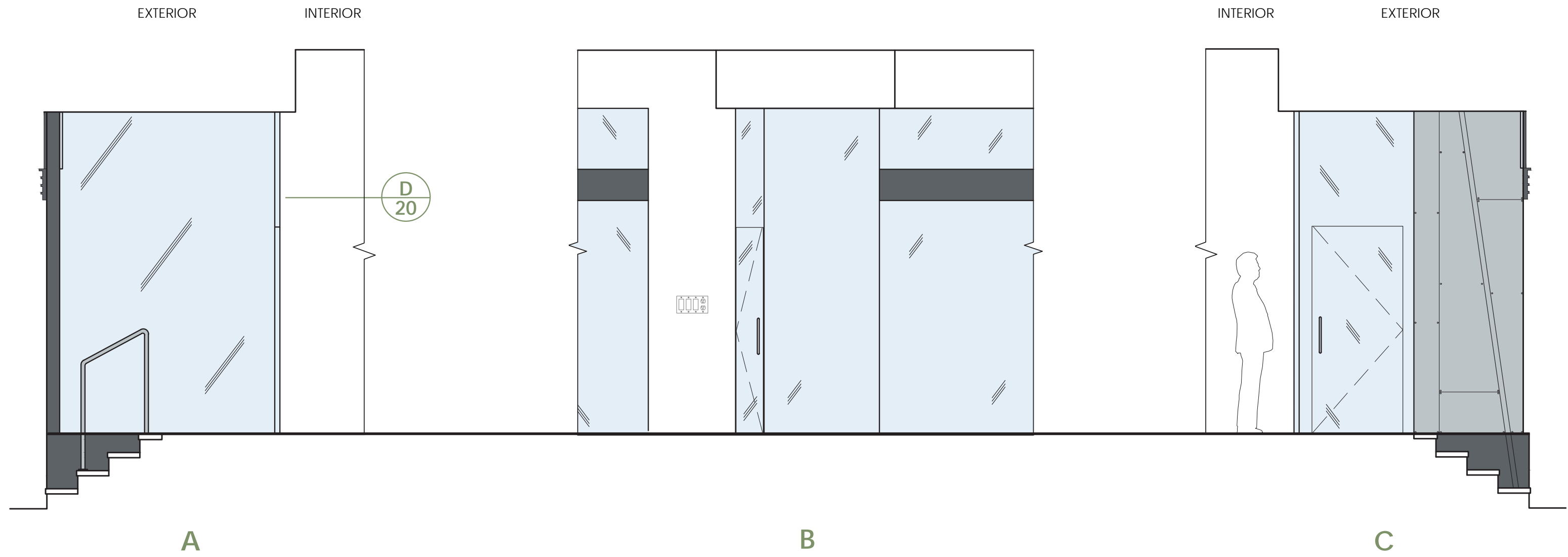

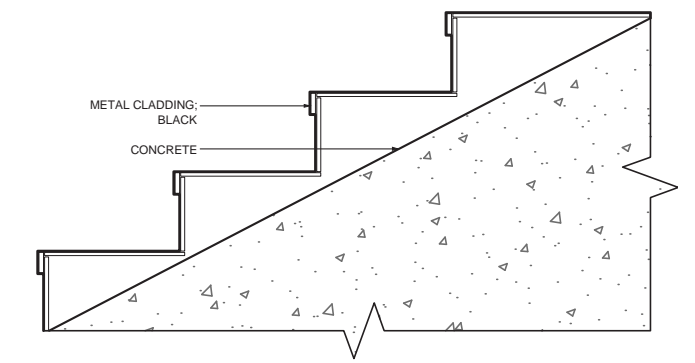
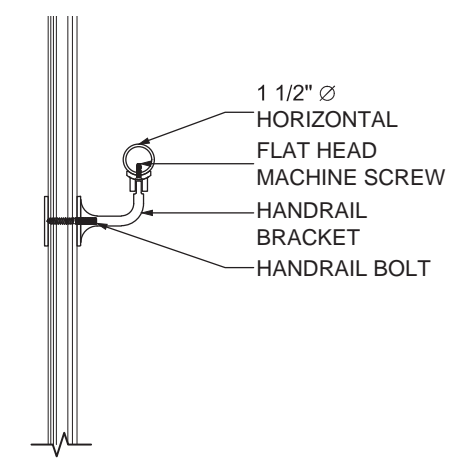
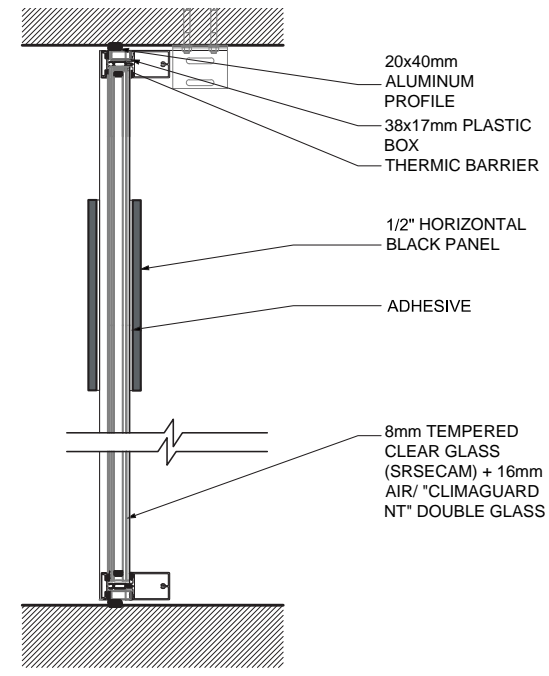
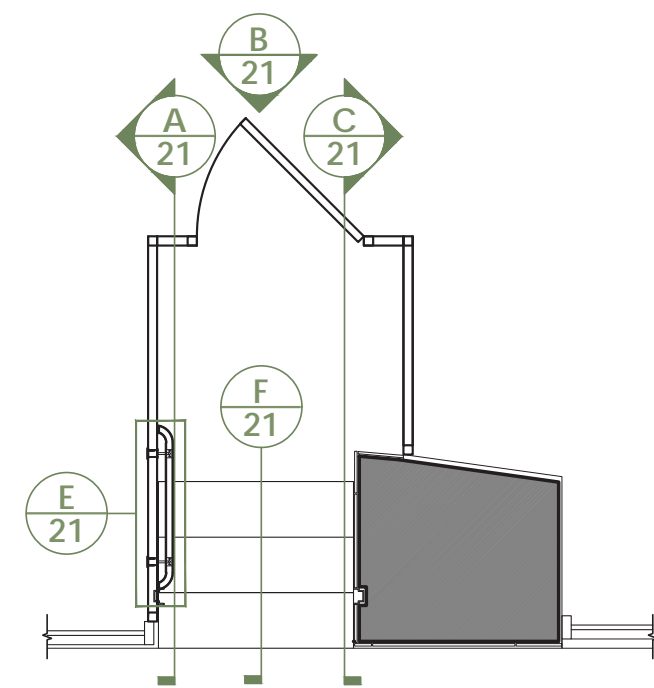
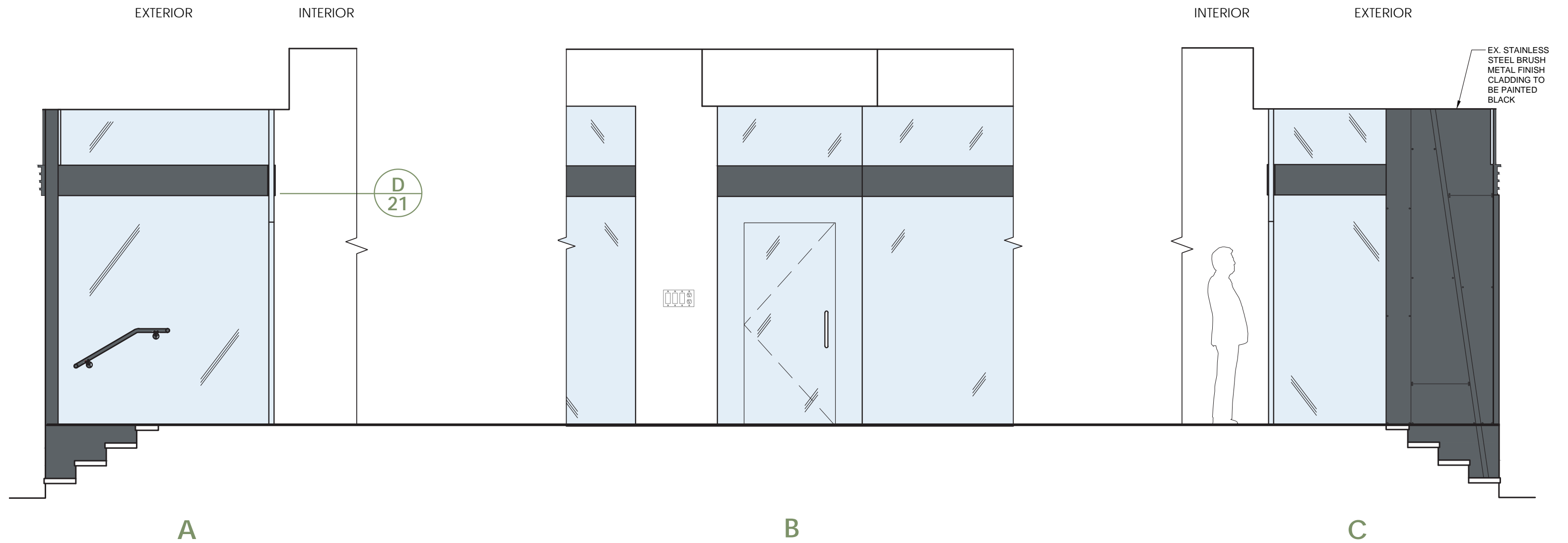

AGED BRASS SIGNAGE

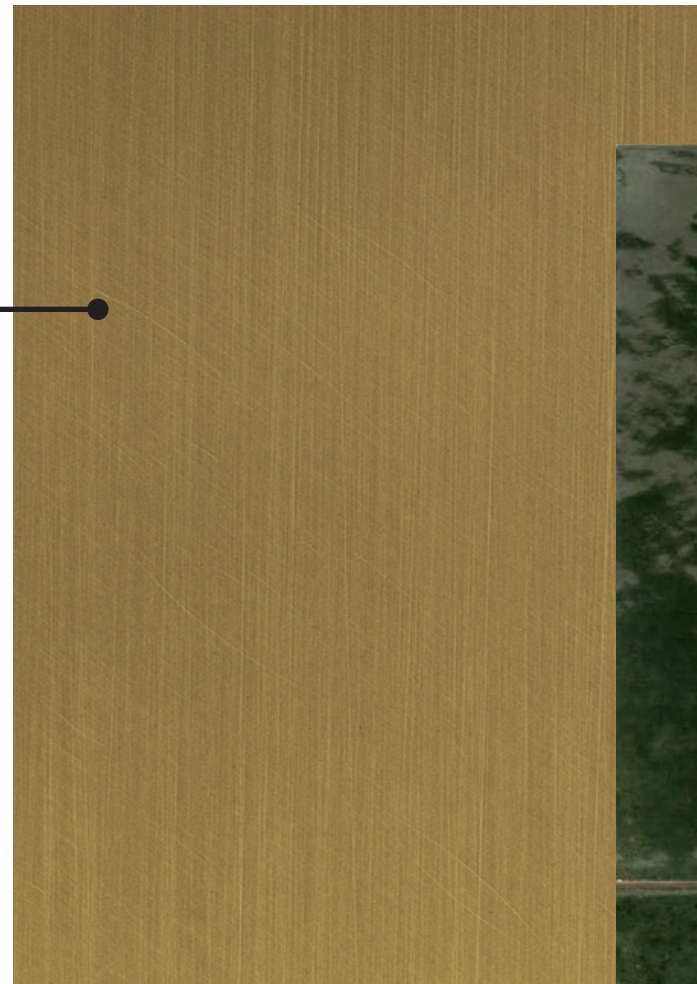

GLASS WINDOWS

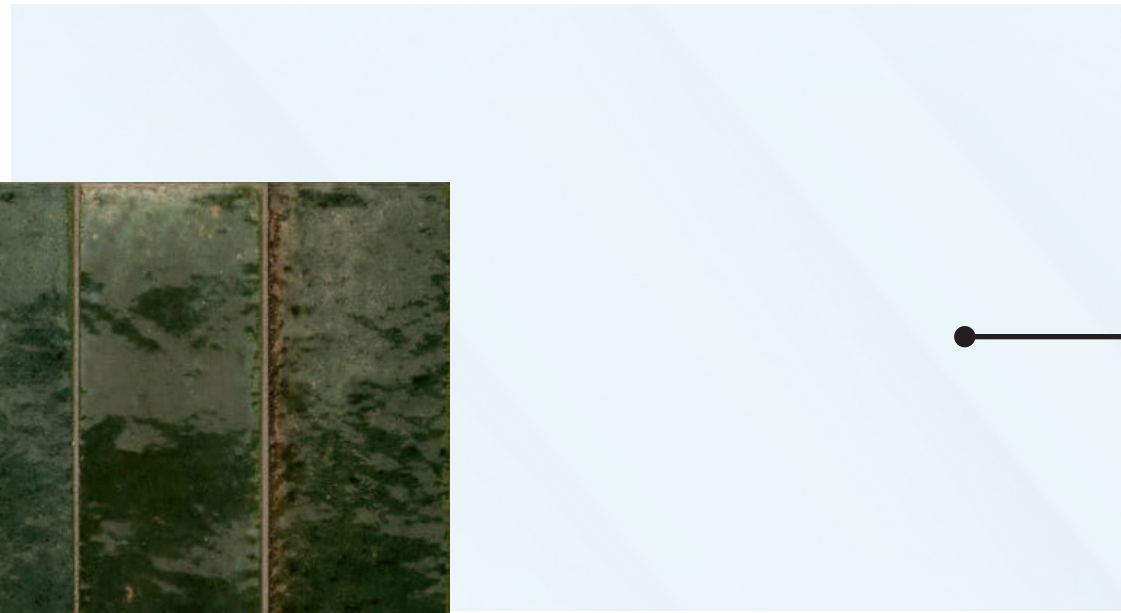

BLACK PAINTED FACADE

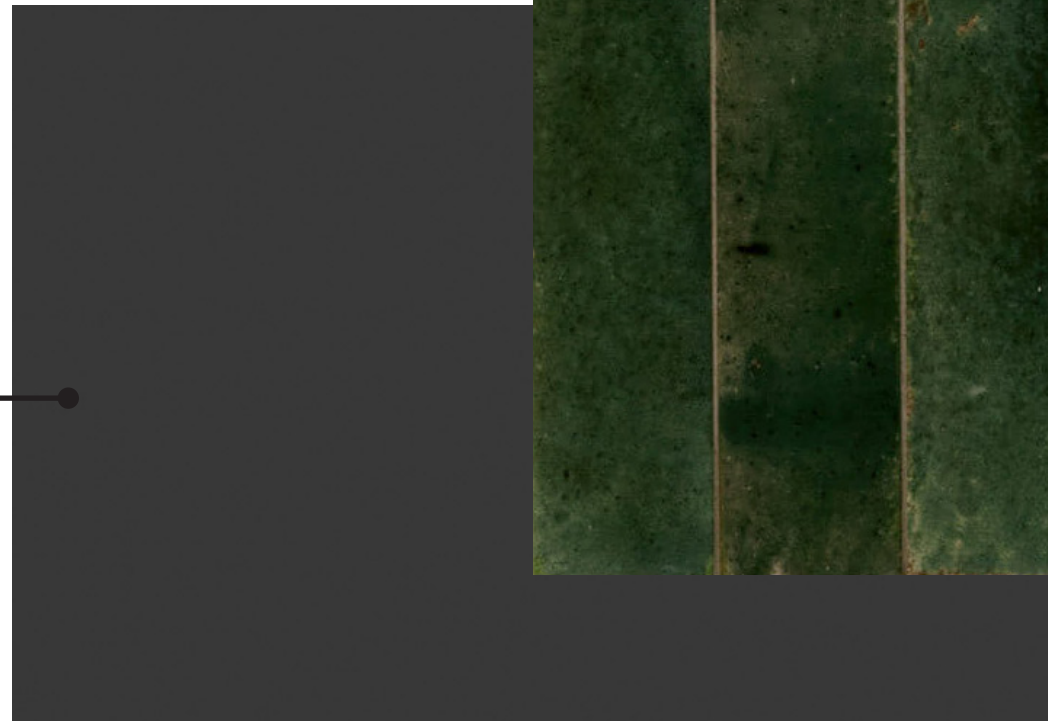

BLACK MATTE STAIR CLADDING



CERAMIC TILE IN FLATIRON OLIVIA





130 West 57th_Proposed Storefront

August 13, 2024
Public Hearing

The current proposal is:

Preservation Department – Item 5, LPC-24-11718

**130 West 57th Street – 130 West 57th Street Studio Building –
Individual Landmark
Borough of Manhattan**

To testify virtually, please join Zoom

Webinar ID: 854 0834 7928

Passcode: 643937

By Phone: 646-558-8656 (NY)

877-853-5257 (Toll free) US

888-475-4499 (Toll free)

Note: If you want to testify virtually on an item, join the Zoom webinar at the agenda's "Be Here by" time (about an hour in advance). When the Chair indicates it's time to testify, "raise your hand" via the Zoom app if you want to speak (*9 on the phone). Those who signed up in advance will be called first.