

September 10, 2024
Public Hearing

The current proposal is:

Preservation Department – Item 2, LPC-25-01205

192 MacDonough Street – Stuyvesant Heights Historic District Borough of Brooklyn

To testify virtually, please join Zoom

Webinar ID: 863 0633 9476

Passcode: 077141

By Phone: 646-558-8656 (NY)

877-853-5257 (Toll free) US

888-475-4499 (Toll free)

Note: If you want to testify virtually on an item, join the Zoom webinar at the agenda's "Be Here by" time (about an hour in advance). When the Chair indicates it's time to testify, "raise your hand" via the Zoom app if you want to speak (*9 on the phone). Those who signed up in advance will be called first.

Bedford Stuyvesant/Expanded Stuyvesant Heights Historic District | LP-2496



SCOPE

- 1. INSTALL STEEL BALCONY ON THE SECOND FLOOR REAR FACADE WITH NO DISTURBANCE OF ANY HISTORICAL MATERIAL

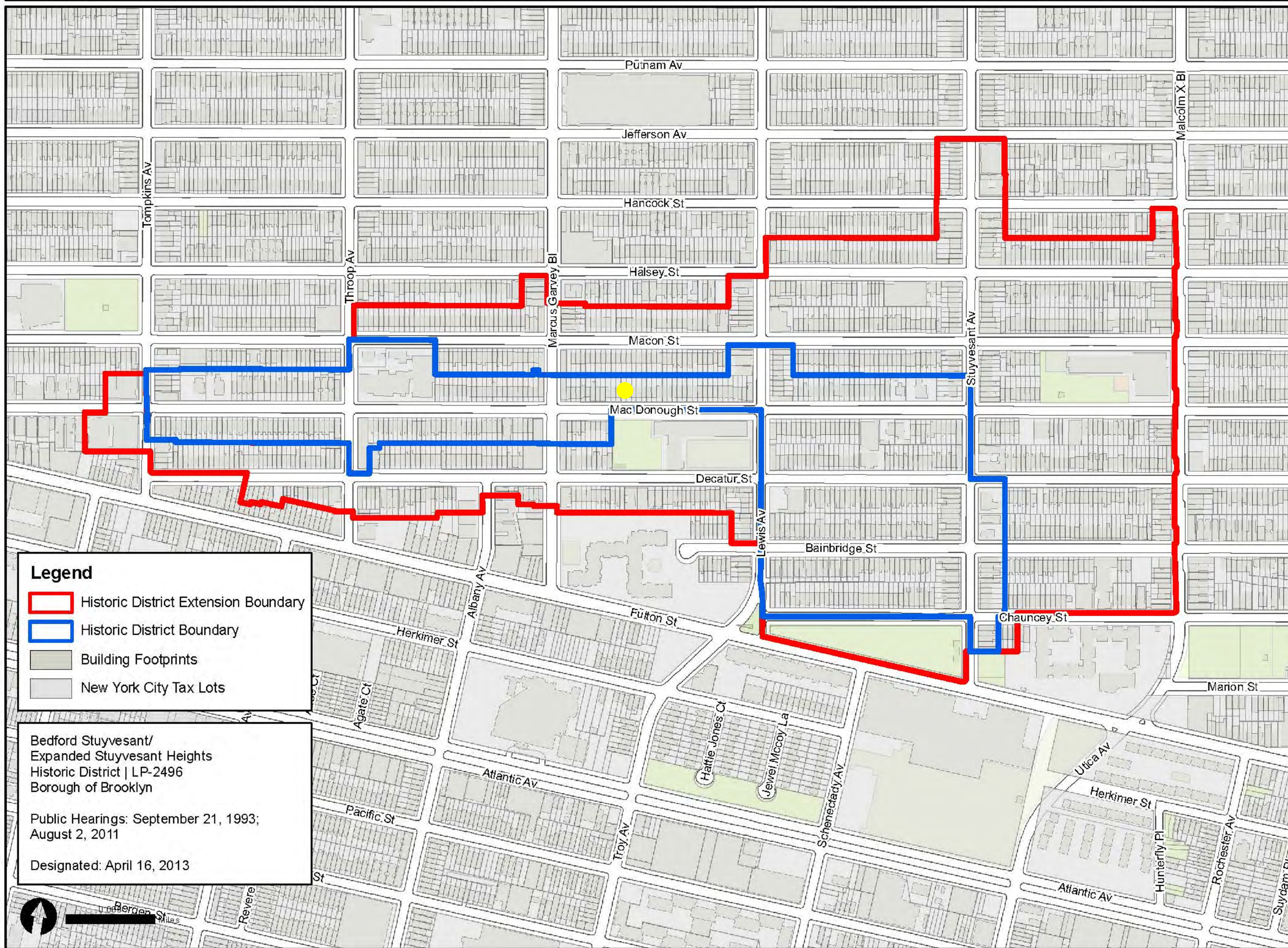

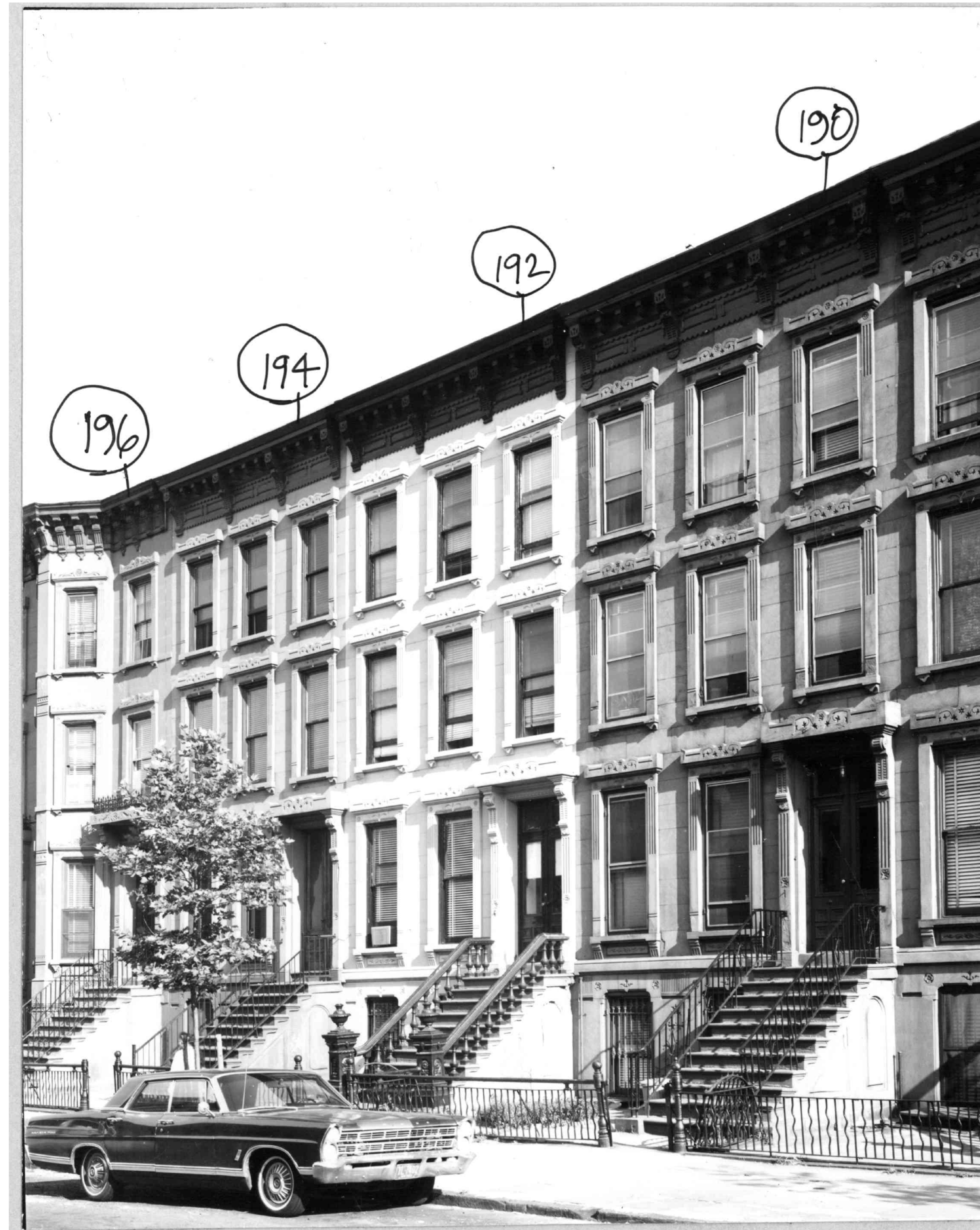

This is the earliest photo on record with the NYC Landmarks Preservation Commission of 192 MacDonough Street.
The photograph is 1940's tax photo



Rear Yard conditions of left adjacent property



Rear Yard condition of right adjacent property



Rear yard conditions

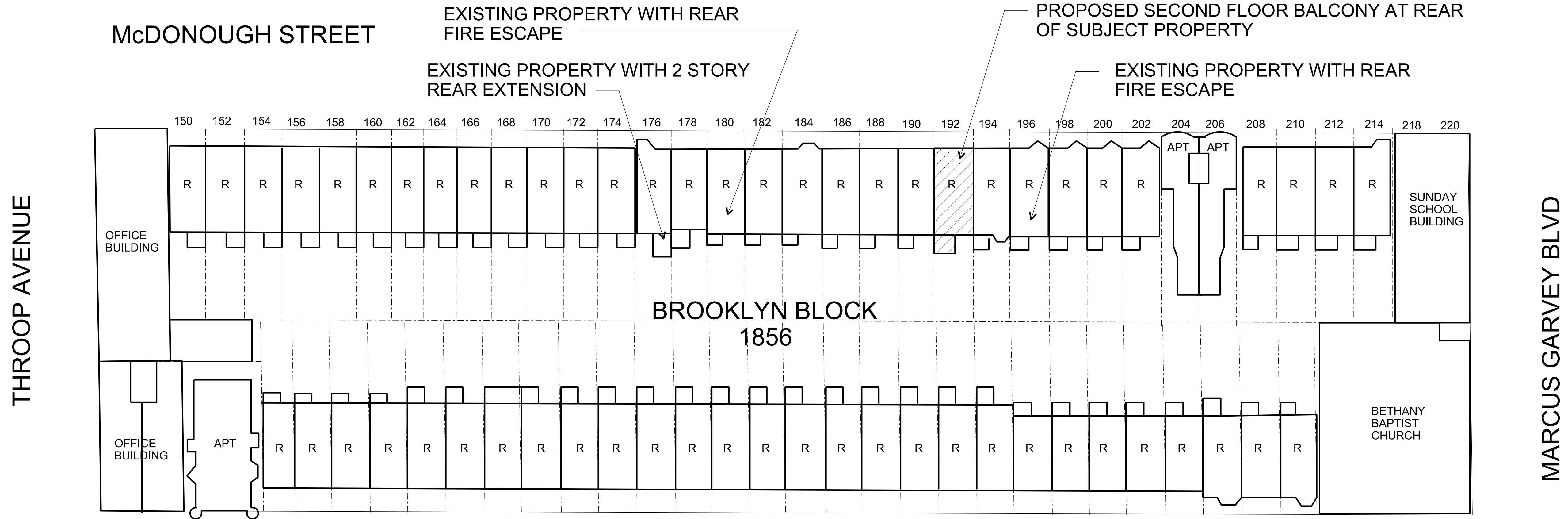

DECATUR STREET

NOTES

1. R = TYPICAL THREE-STORY ROW HOUSE
2. ALL REAR EXTENSIONS ARE SINGLE STORY UNLESS NOTED OTHERWISE
3. THE PROPOSED SECOND FLOOR BALCONY IN THE REAR AT 192 WILL NO BE VISIBLE FROM ANY OF THE STREET SURROUNDING THE BLOCK



2-STORY EXTENSION AT 176 MACDONOUGH ST
EXISTING FIRE ESCAPE AT 180 MACDONOUGH ST



EXISTING FIRE ESCAPE AT 196 MACDONOUGH ST

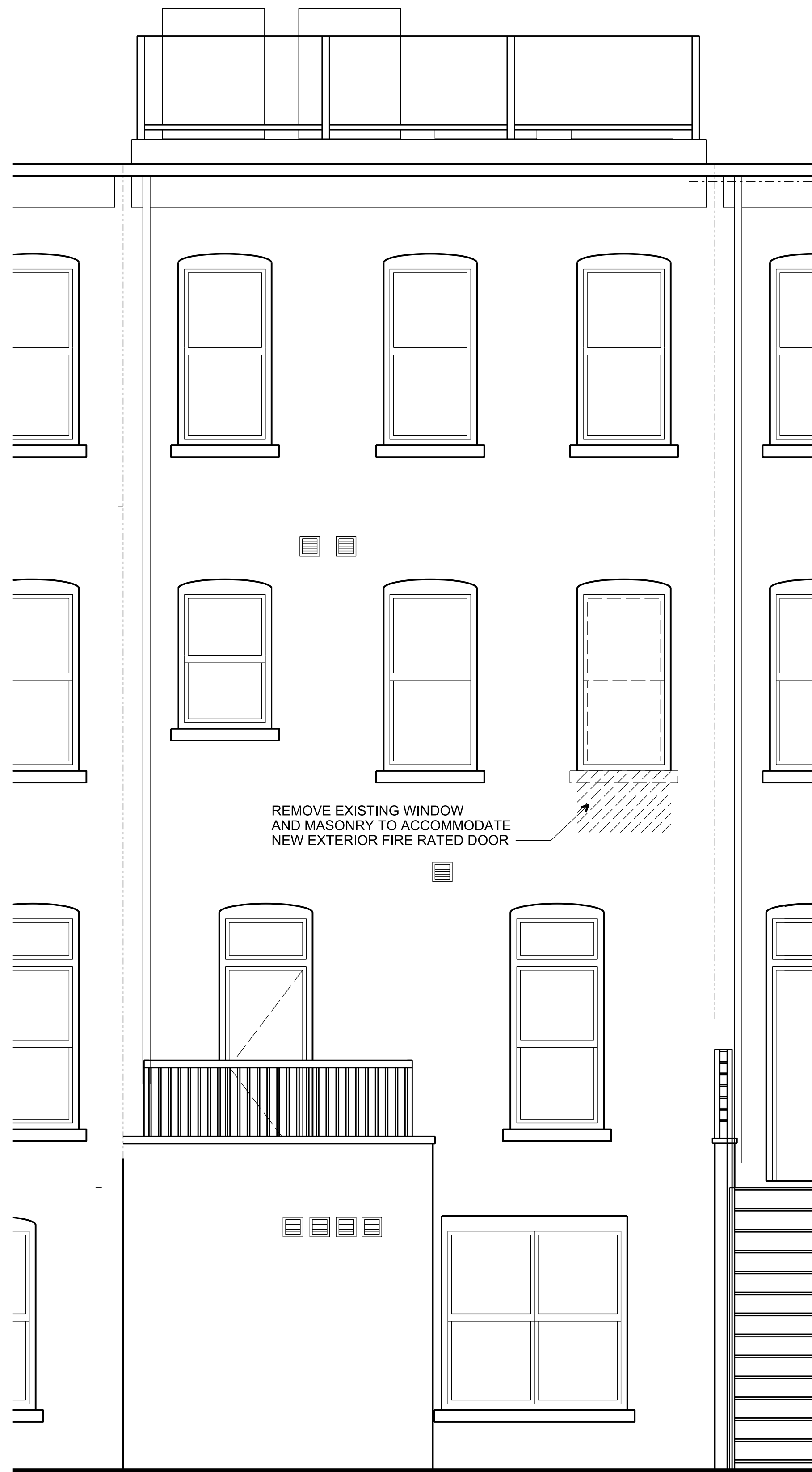

DEMOLITION WORK



190

192

194

REAR ELEVATION WITH SECOND FLOOR BALCONY

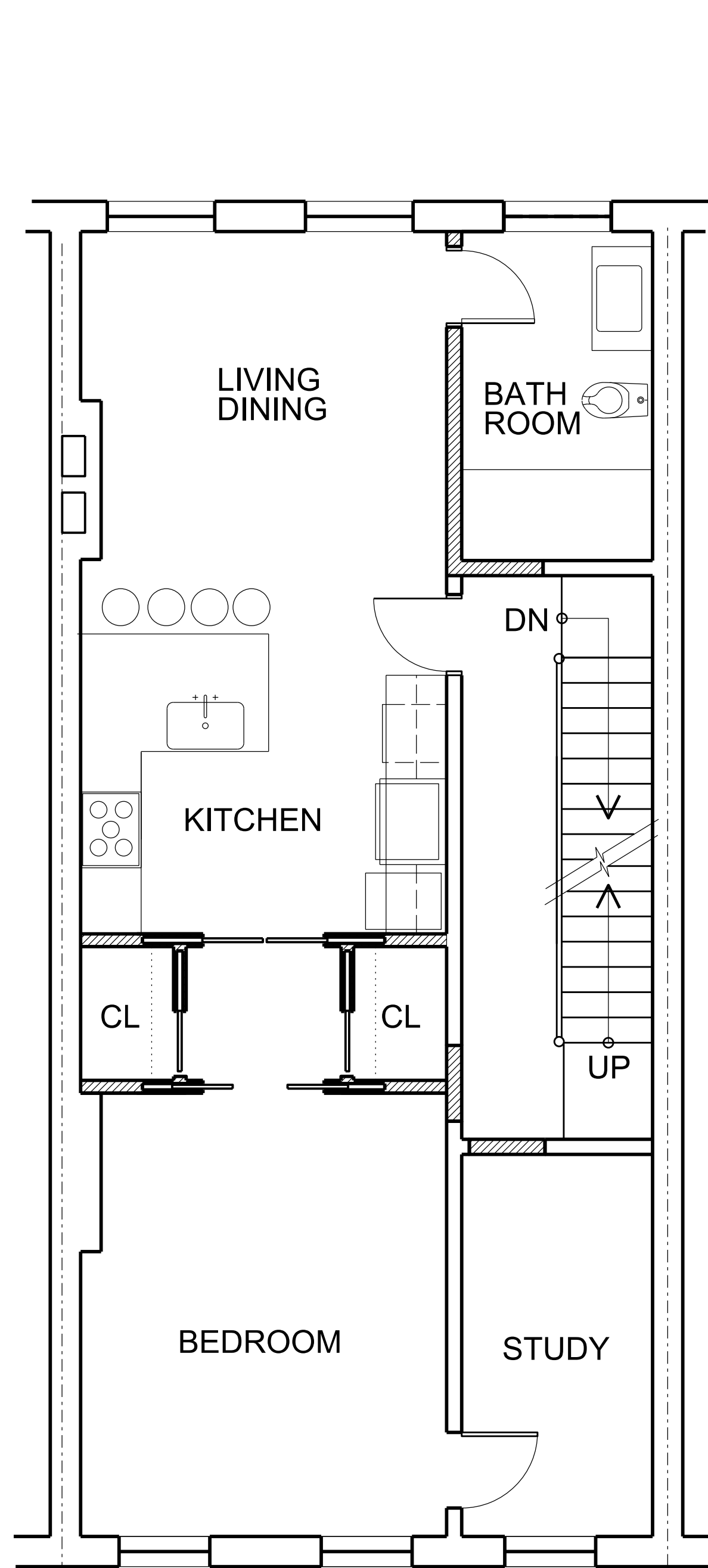
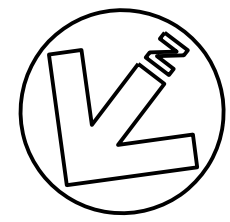

SECOND FLOOR (BEFORE)

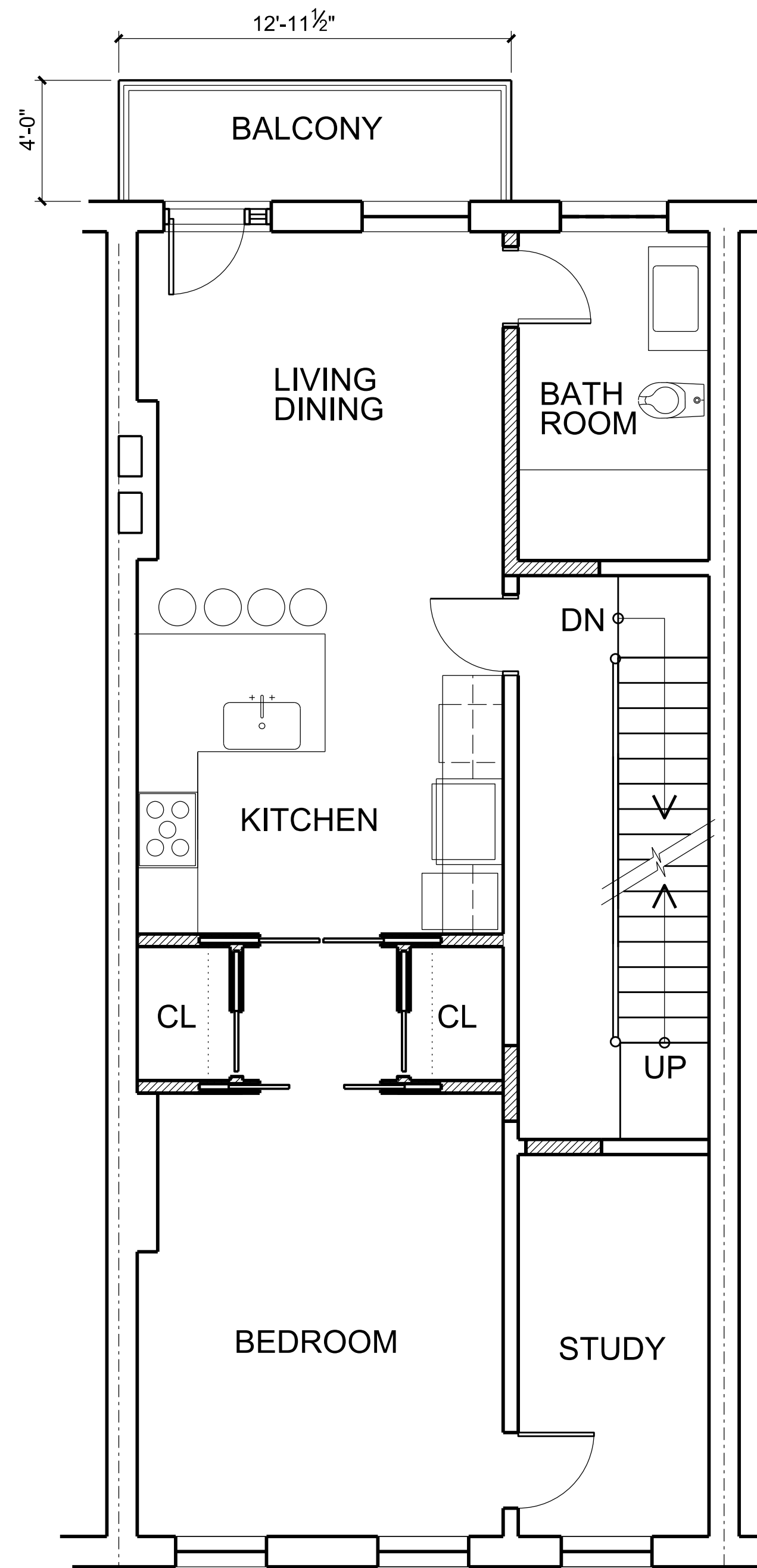

SECOND FLOOR (AFTER)

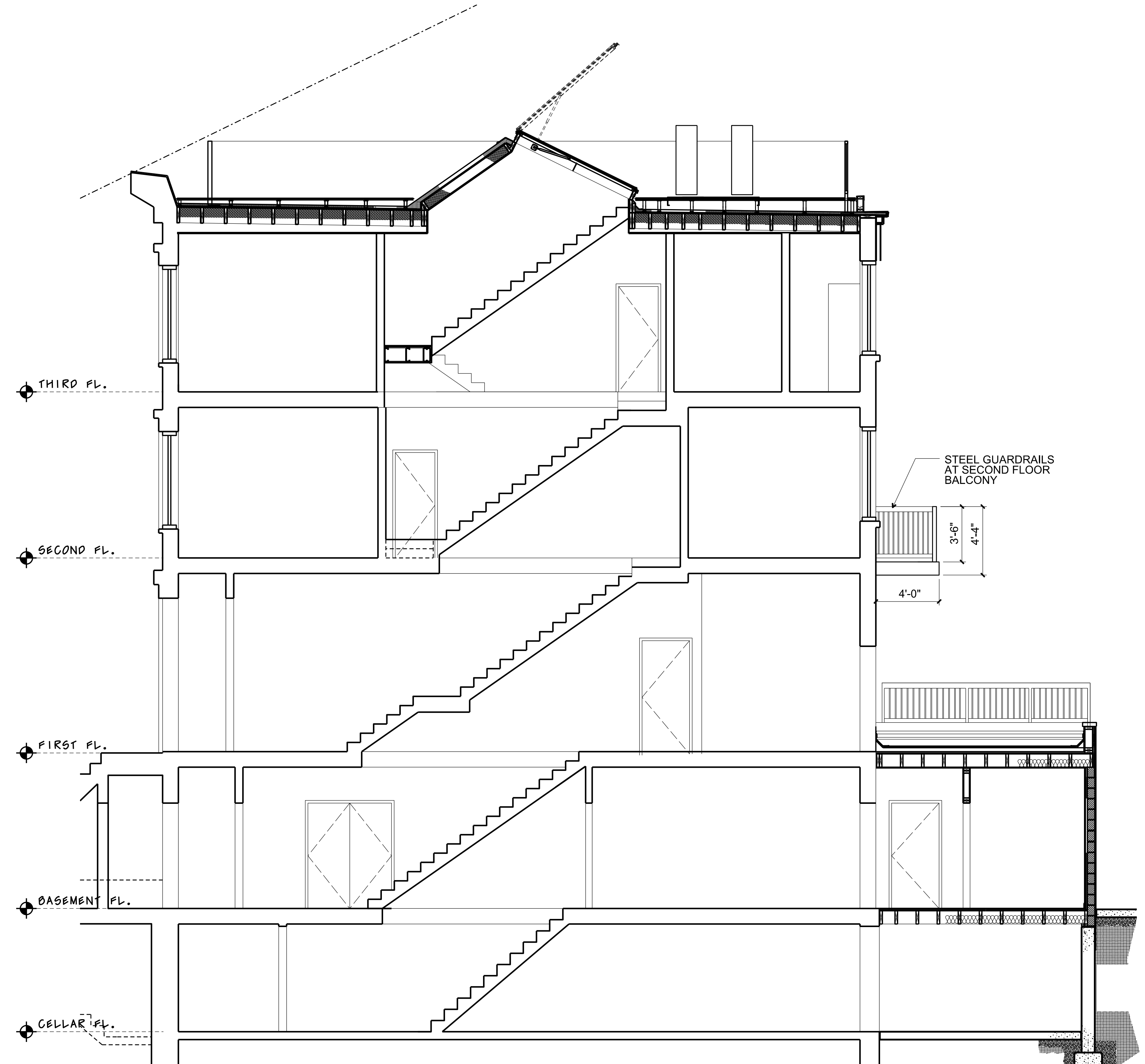

BUILDING SECTION



EXAMPLE OF SECOND FLOOR BALCONY



EXAMPLE OF SECOND FLOOR BALCONY

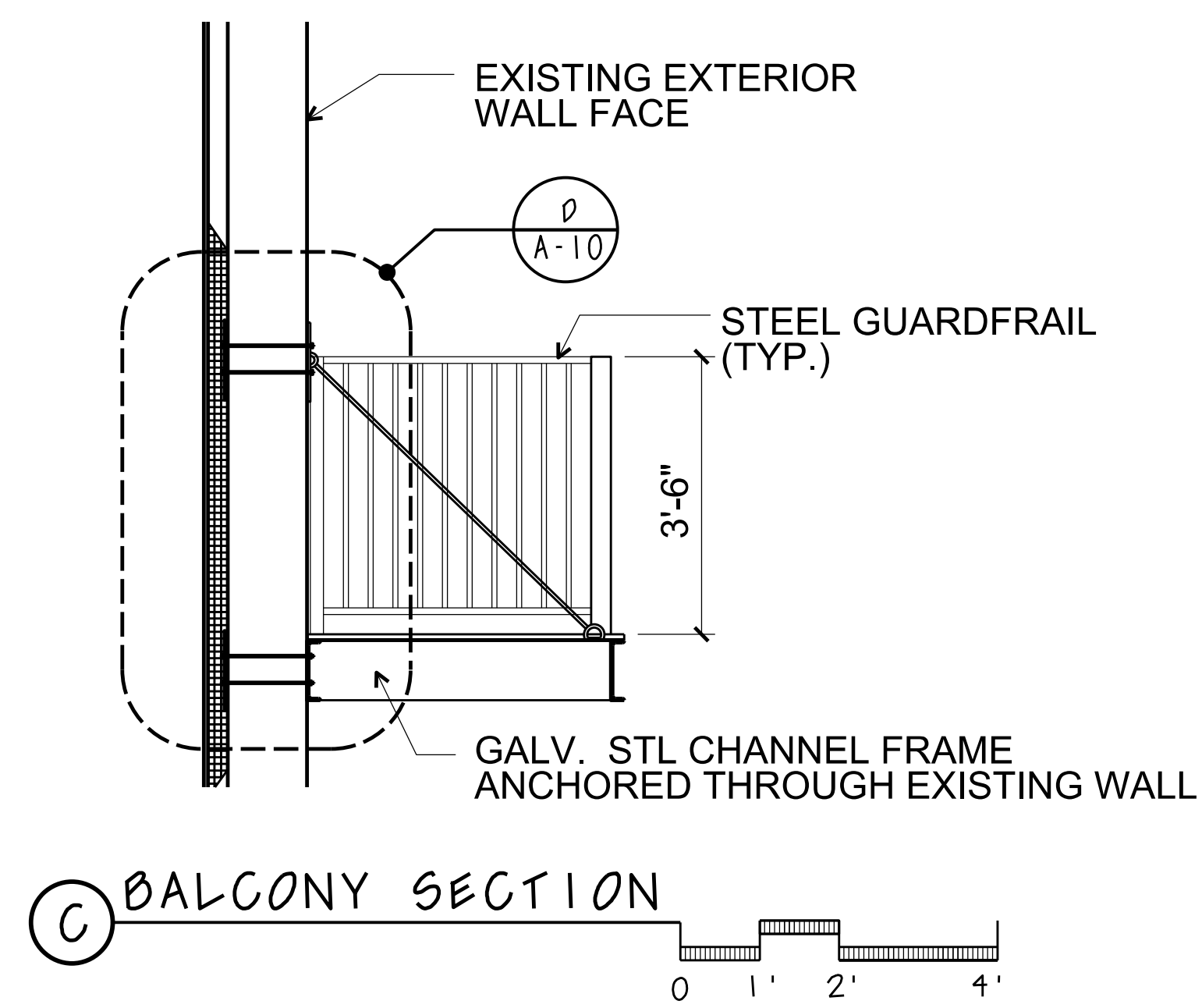
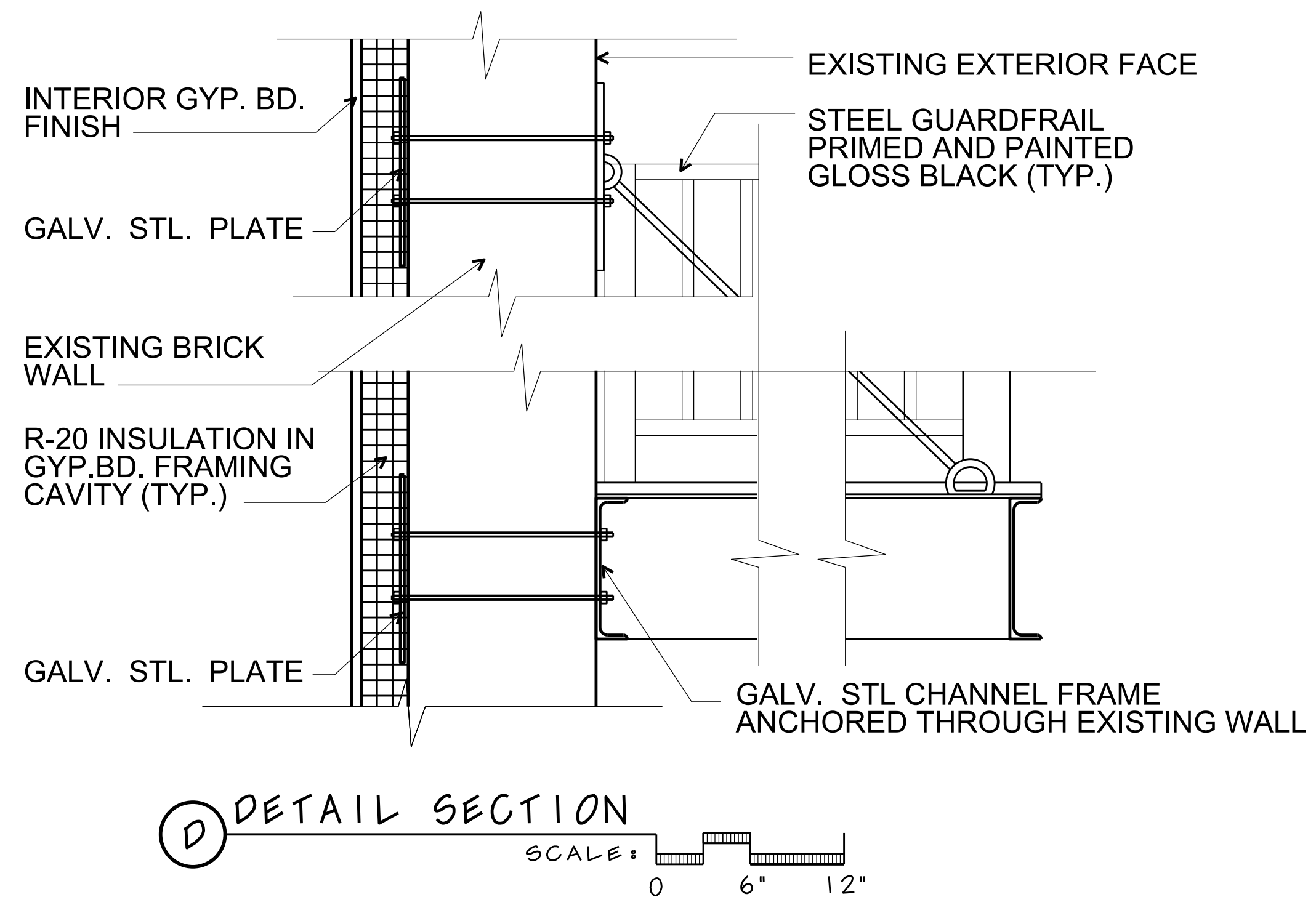
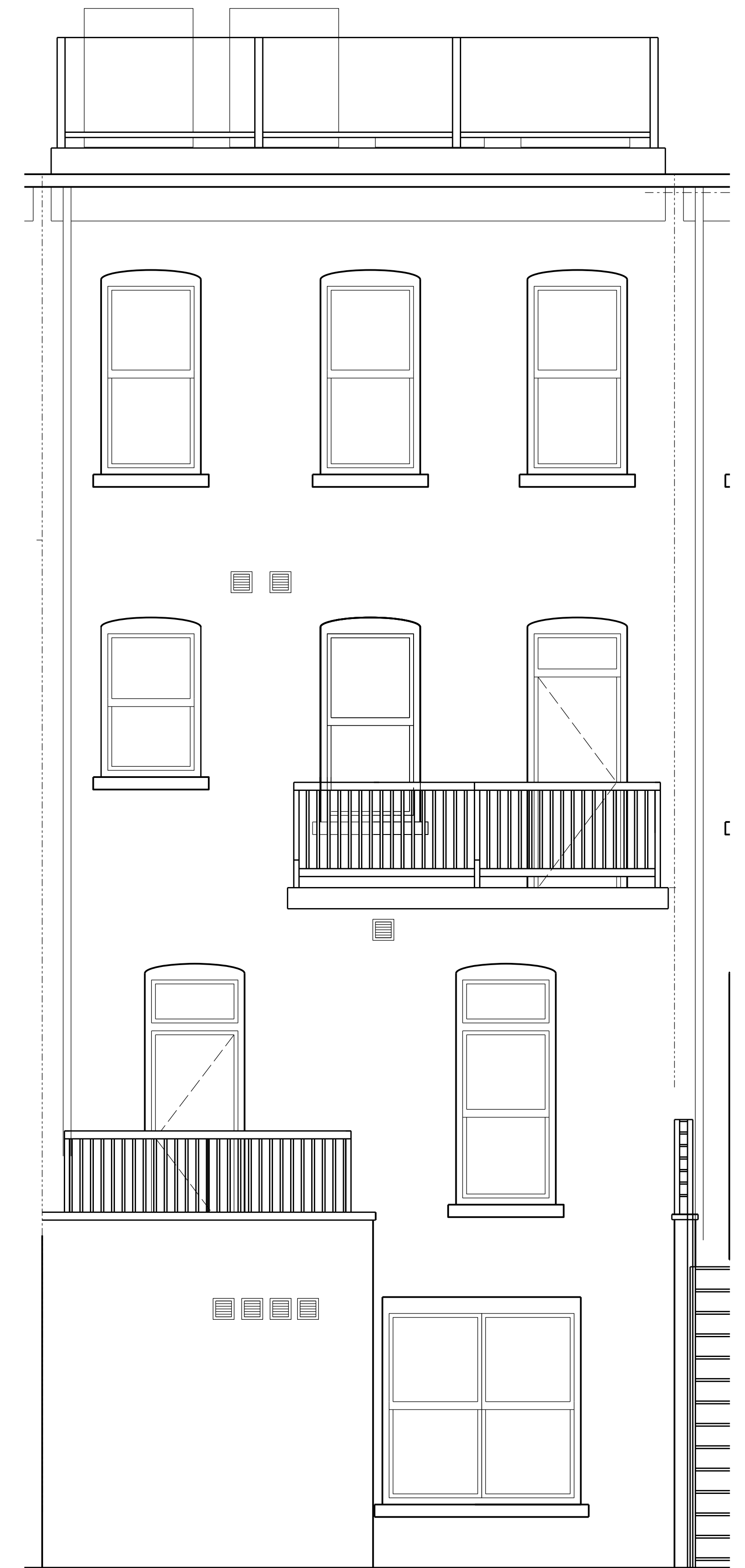

September 10, 2024
Public Hearing

The current proposal is:

Preservation Department – Item 2, LPC-25-01205

192 MacDonough Street – Stuyvesant Heights Historic District Borough of Brooklyn

To testify virtually, please join Zoom

Webinar ID: 863 0633 9476

Passcode: 077141

By Phone: 646-558-8656 (NY)

877-853-5257 (Toll free) US

888-475-4499 (Toll free)

Note: If you want to testify virtually on an item, join the Zoom webinar at the agenda's "Be Here by" time (about an hour in advance). When the Chair indicates it's time to testify, "raise your hand" via the Zoom app if you want to speak (*9 on the phone). Those who signed up in advance will be called first.